

2CAM



Pressurisation units with 2 self-priming pumps of CAM series on a single skid, connected in parallel by suction and delivery manifolds.

They are available in fixed speed version with electronic control panel or in variable speed version with EPIC inverters for constant pressure. The key characteristics of these systems are their reliability, user-friendly operation, and low maintenance needs. Installation of a pressure tank is required.

Booster set features

Suction manifold	galvanized steel with non-return and isolation valves
Delivery manifold	galvanized steel with pressure gauge and isolation valves, two connectors in the delivery manifold for direct installation of pressure tanks up to 24 lt
Base frame	galvanized steel
Fixed speed	electronic control panel EQ2SM(T) and two pressure switches
Variable speed	inverter EPIC on each pump and two pressure sensors
Pressure tanks	available on request as accessories

Pump features

Pump body, mechanical seal housing	cast iron
Motor bracket	aluminum (100N÷140) cast iron (150÷300)
Impellers, diffusers	Noryl®, brass, inox for 100N÷140
Mechanical seal	ceramic-graphite-NBR
Motor shaft	stainless steel AISI 416
Liquid temperature	0 - 50 °C
Operating pressure	max 7 bar (100N÷140) max 8 bar (150÷300)
2 poles induction motor	3~ 230/400V - 50Hz 1~ 230V - 50Hz
Motor insulation class	F
Motor protection degree	IPX4

PERFORMANCE

TARGET (2 pumps)		MODEL			P2 NOMINAL		Q (m³/h - l/min)											
		FIXED SPEED		VARIABLE SPEED			0	1,2	2,4	3,6	4,8	6	6,6	7,2	8,4	9,6	12	14,4
l/min	bar	1- 230V	3- 400V	1- 230V-in 3- 230V-out	HP (x2)	kW (x2)	0	20	40	60	80	100	110	120	140	160	200	240
		H (m)																
80	3	2CAM 100N	2CAMT 100N	2CAMT/E 100N	1	0,74	50,9	44,3	38,9	34,1	30,1	26,3	24,6	23,0	20,0			
100	3	2CAM 120	2CAMT 120	2CAMT/E 120	1,2	0,88	55,1	48,5	42,6	37,8	33,5	29,7	27,9	26,2	23,0			
120	3	2CAM 140	2CAMT 140	2CAMT/E 140	1,5	1,1	62,5	55,7	49,4	44,2	39,5	35,5	33,5	31,6	28,1			
140	3,5	2CAM 150	2CAMT 150	2CAMT/E 150	2	1,5	54,8	51,8	48,9	46,2	43,6	41,1	40,0	38,8	36,6	34,5	30,6	26,8
160	4	2CAM 200	2CAMT 200	-	2,5	1,85	62,7	59,7	56,8	54,0	51,5	49,1	47,9	46,8	44,6	42,4	38,4	34,8
180	4,5	2CAM 300	2CAMT 300	-	3	2,2	70,0	66,9	63,9	61,0	58,3	55,8	54,6	53,5	51,3	49,2	45,1	41,6



Name key

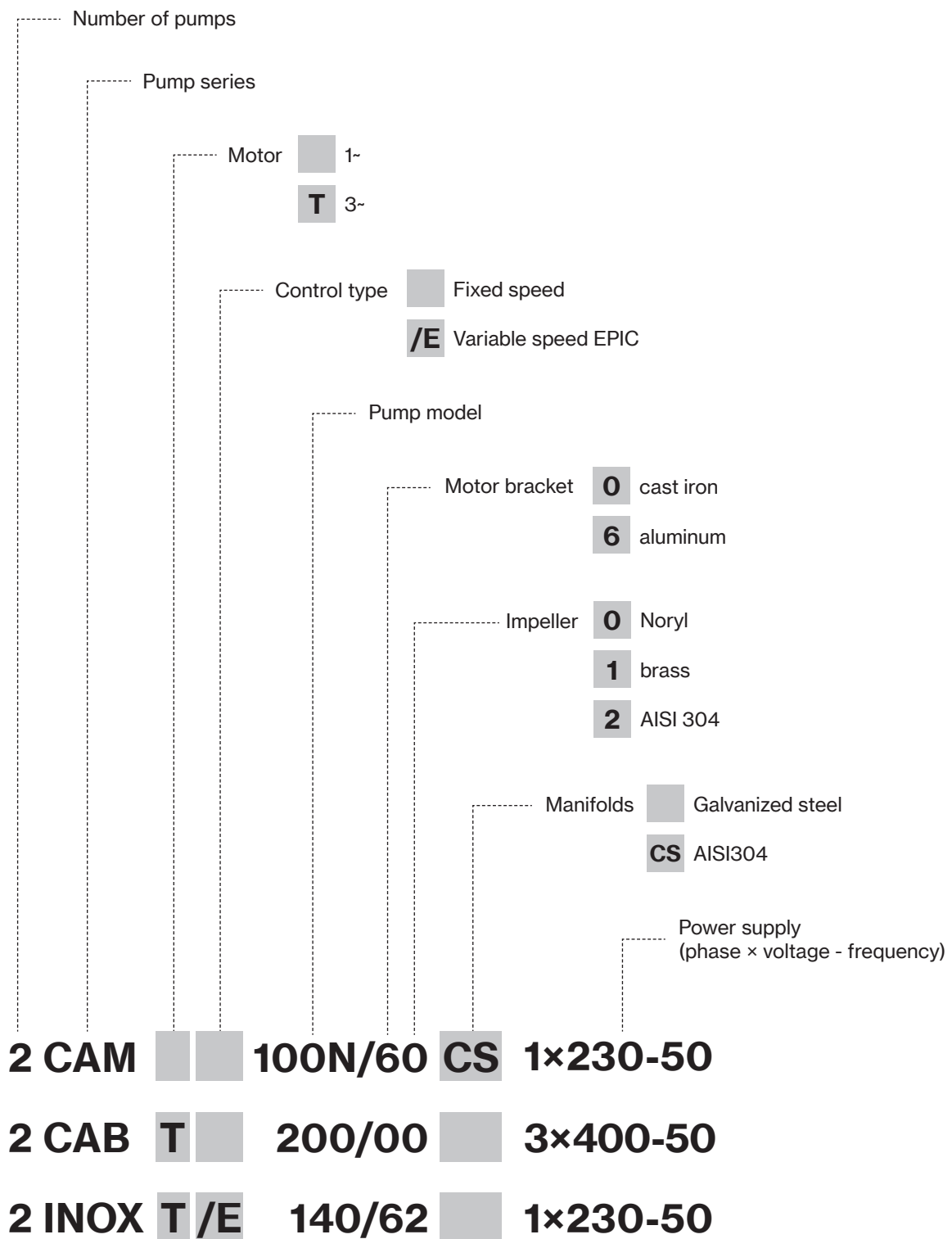

Performance data and curves

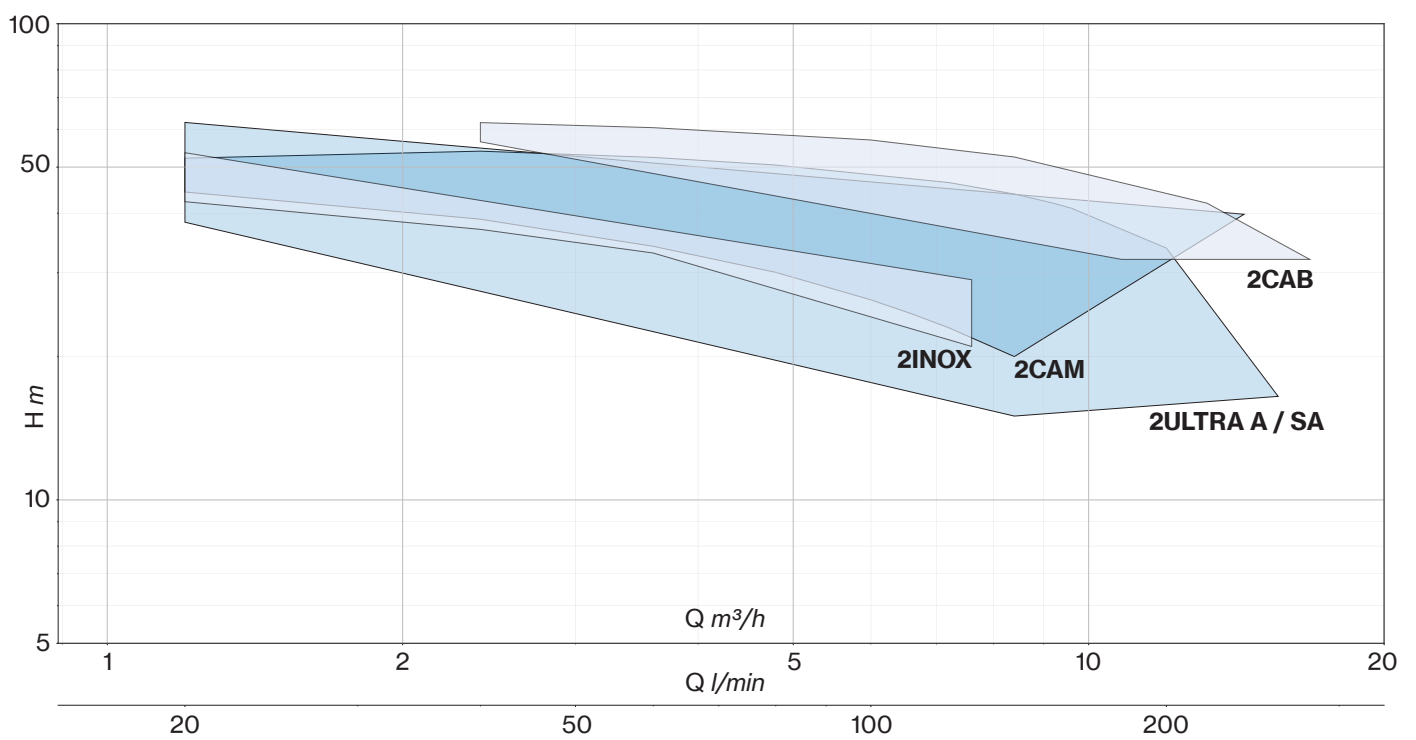

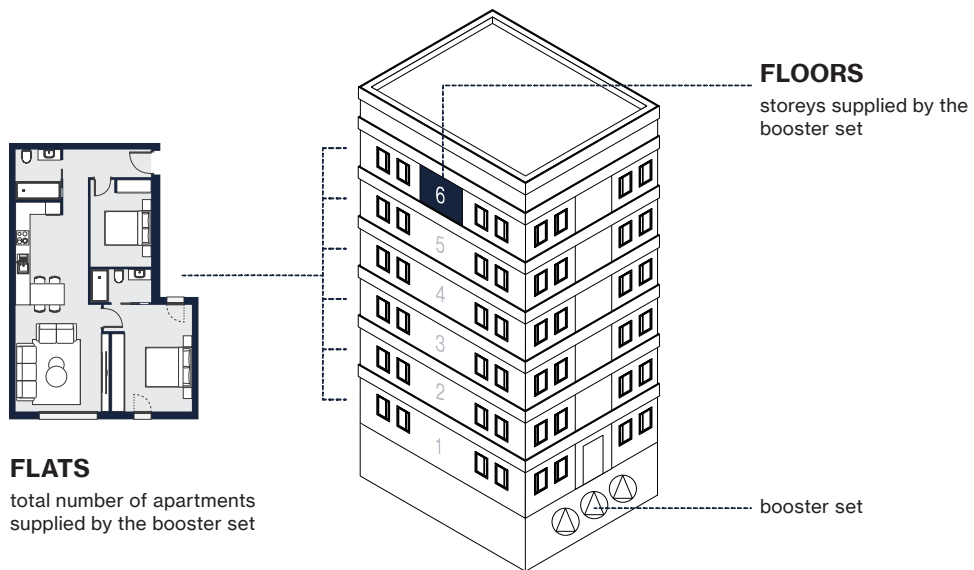

FLATS		FLOORS	ULTRA A series	ULTRA SA series	CAM series	INOX series	CAB series
1 duty and 1 standby pumps	2 duty pumps						
1	1-2	1-2	2U3A_-90/4_	2U3SA_-90/4_	2CAM_100N	2INOX_100N	-
		3	-	2U3SA_-90/4_	2CAM_100N	-	-
2	3-4	1-2	2U3A_-100/5_	2U3SA_-90/4_	2CAM_120	2INOX_120	-
		3	2U3A_-100/5_	2U3SA_-100/5_	2CAM_140	2INOX_140	-
		4	-	2U3SA_-100/5_	2CAM_140	-	-
		5	-	-	-	-	2CAB_150
3-4	5-8	1-2	2U5A_-120/4_	2U5SA_-120/4_	2CAM_140	2INOX_140	-
		3	2U5A_-120/4_	2U5SA_-120/4_	2CAM_150	-	-
		4	2U5A_-150/5_	2U5SA_-150/5_	2CAM_200	-	2CAB_150
		5	2U5A_-150/5_	2U5SA_-150/5_	2CAM_200	-	2CAB_150
		6	2U5A_-150/5_	2U5SA_-150/5_	2CAM_300	-	2CAB_200
		7	-	-	2CAM_300	-	2CAB_200
		8	-	-	-	-	2CAB_300

2CAM

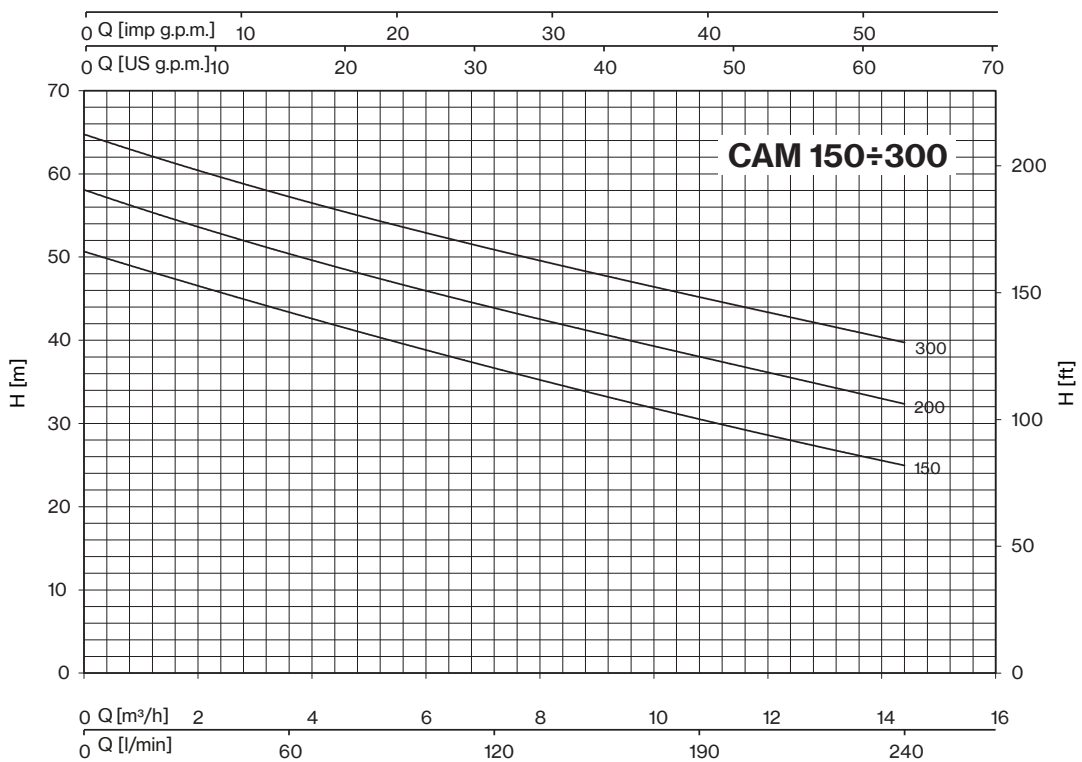
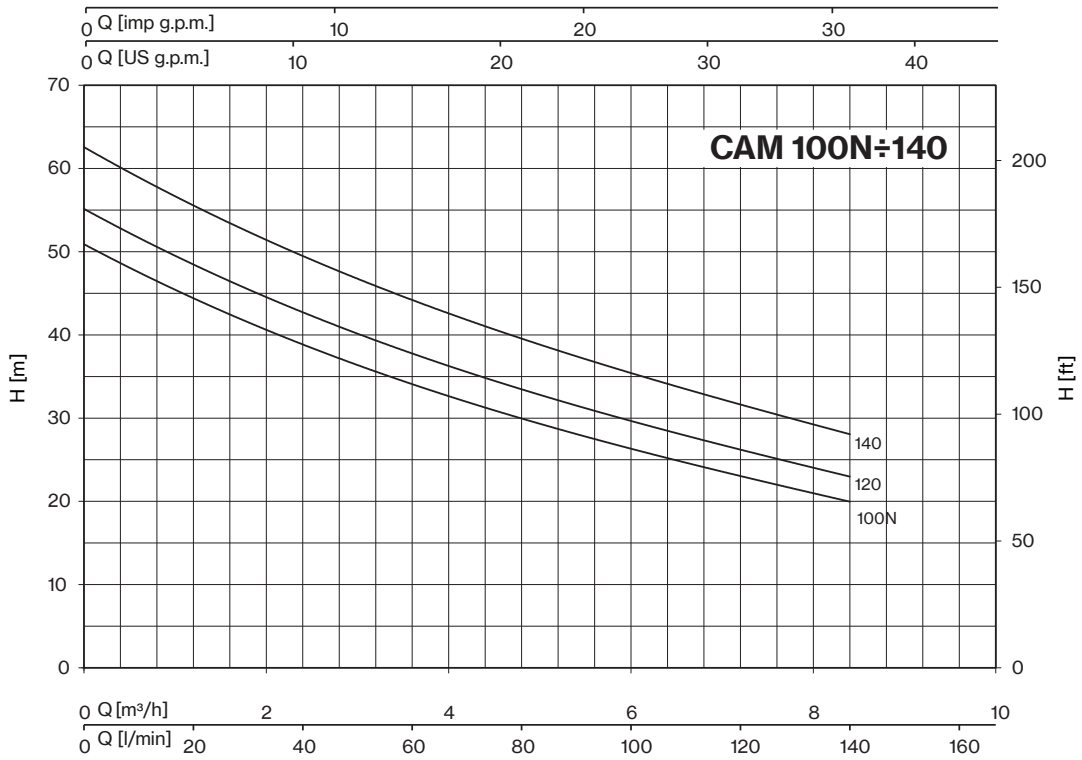

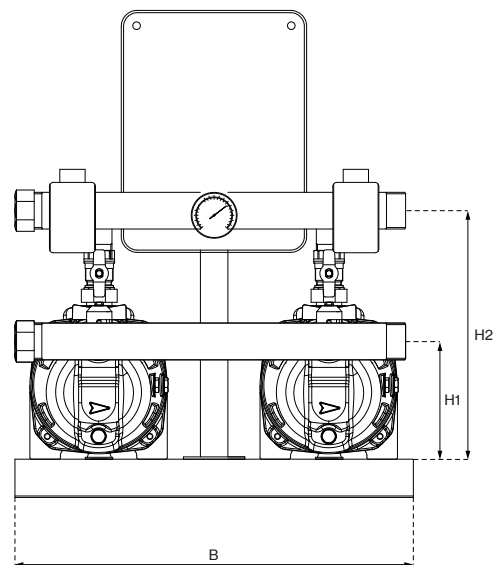
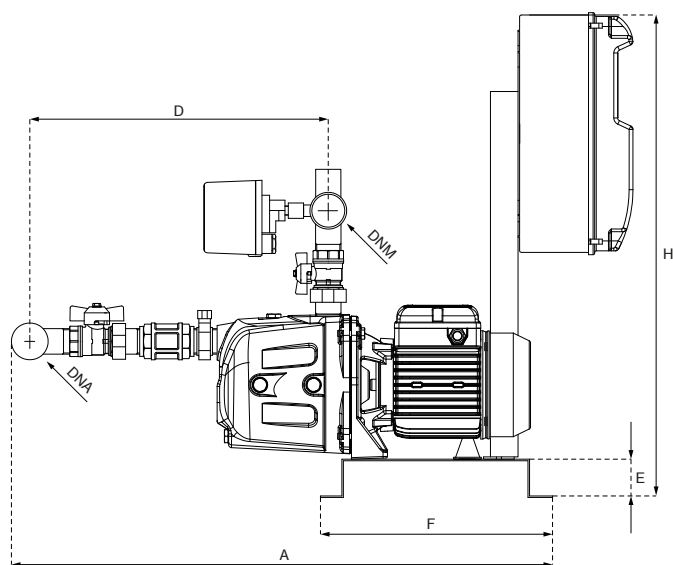

MODEL			P1		In			Required tank for v.s. Lt	DIMENSIONS										WEIGHT	
FIXED SPEED		VARIABLE SPEED	1~	3~	1~ 230V	3~ 400V	3~ 230V		A	B	D	E	F	H	H1	H2	DNA	DNM	f.s.	v.s.
1- 230V	3- 400V	1- 230V-in 3- 230V-out	kW (x2)		A (x2)		mm												Kg	
2CAM 100N	2CAMT 100N	2CAMT/E 100N	1,04	0,92	4,7	1,7	2,9	2x 8	745	520	383	50	300	650	150	325	1" 1/2 G	1" 1/2 G	49	54
2CAM 120	2CAMT 120	2CAMT/E 120	1,14	1,07	5,2	1,9	3,3	2x 8	745	520	383	50	300	650	150	325			50	55
2CAM 140	2CAMT 140	2CAMT/E 140	1,3	1,25	6	2,5	4,3	2x 8	745	520	383	50	300	650	150	325			51	56
2CAM 150	2CAMT 150	2CAMT/E 150	1,9	1,8	8,5	3,7	6,4	2x 20	850	615	474	60	380	650	175	360	2" G		85	90
2CAM 200	2CAMT 200	-	2,3	2,2	10,4	4,4	7,6	2x 20	850	615	474	60	380	650	175	360			83	-
2CAM 300	2CAMT 300	-	2,7	2,6	12,5	5,2	9	-	850	615	474	60	380	650	175	360			84	-

f.s. : fixed speed
v.s. : variable speed

