

2CM



Pressurisation units with 2 threaded centrifugal pumps of CM series on a single skid, connected in parallel by suction and delivery manifolds.

They are available in fixed speed version with electronic control panel or in variable speed version with EPIC and EPIC-A inverters for constant pressure. The key characteristics of these systems are their reliability, user-friendly operation, and low maintenance needs. Installation of a pressure tank is required.

Booster set features

Suction manifold	galvanized steel with non-return and isolation valves
Delivery manifold	galvanized steel with pressure gauge and isolation valves, two connectors in the delivery manifold for direct installation of pressure tanks up to 24 lt
Base frame	galvanized steel
Fixed speed	electronic control panel EQ2SM(T) and two pressure switches
Variable speed	inverter EPIC or EPIC-A on each pump and two pressure sensors
Pressure tanks	available on request as accessories

Pump features

Pump body	cast iron
Motor bracket	cast iron (164÷550); aluminum (100)
Impeller	Noryl® or brass (100÷314), brass (400÷550)
Mechanical seal	ceramic-graphite-NBR
Motor shaft	stainless steel AISI 416 (100) stainless steel AISI 303 (164÷550)
Liquid temperature	Noryl® impeller: 0 - 50 °C brass impeller: 0 - 90 °C
Operating pressure	max 6 bar (100) max 8 bar (164÷550)
2 Poles induction motor	3~ 230/400V - 50Hz 1~ 230V - 50Hz
Motor insulation class	F
Motor protection degree	IPX4

Name key

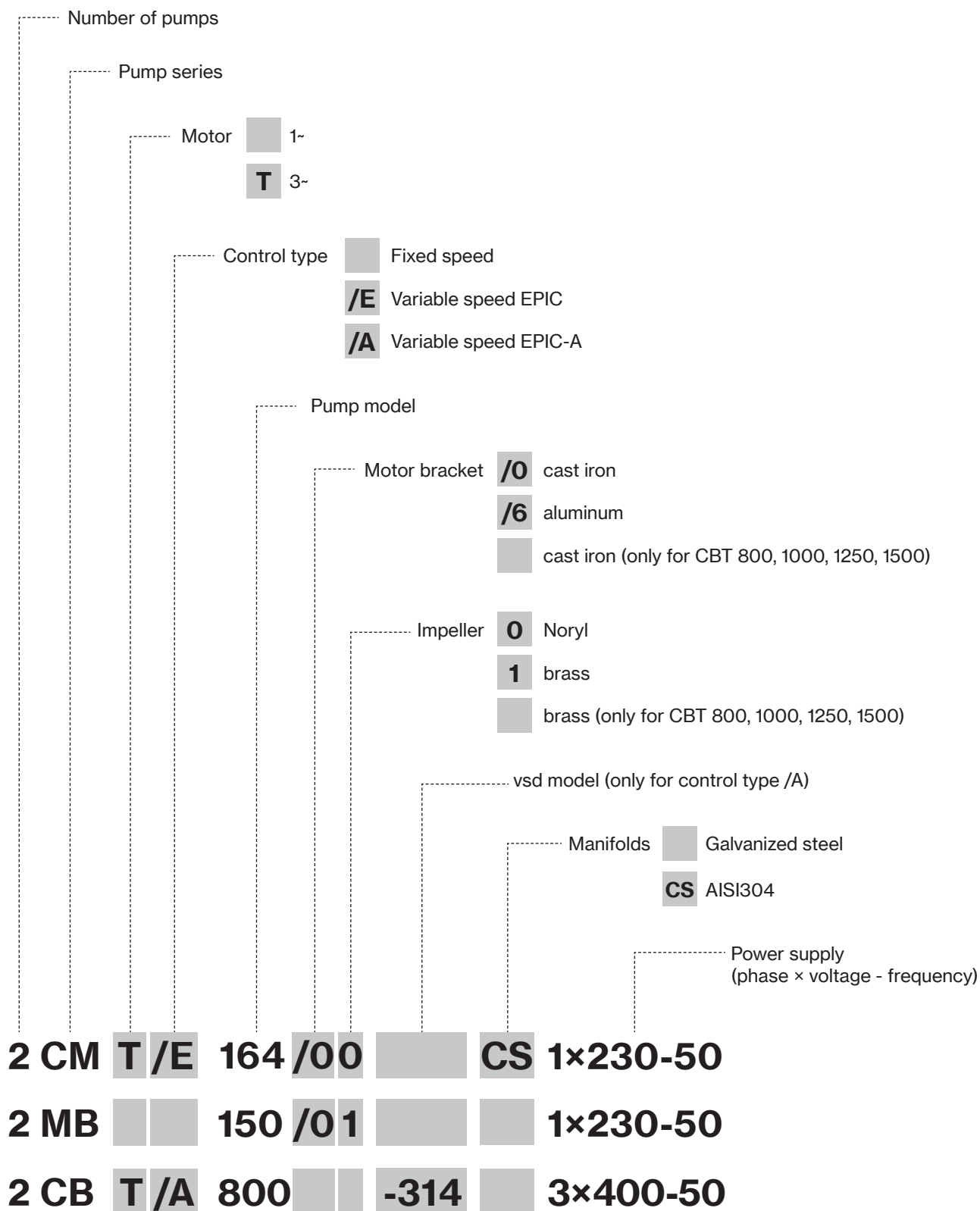

Performance data and curves

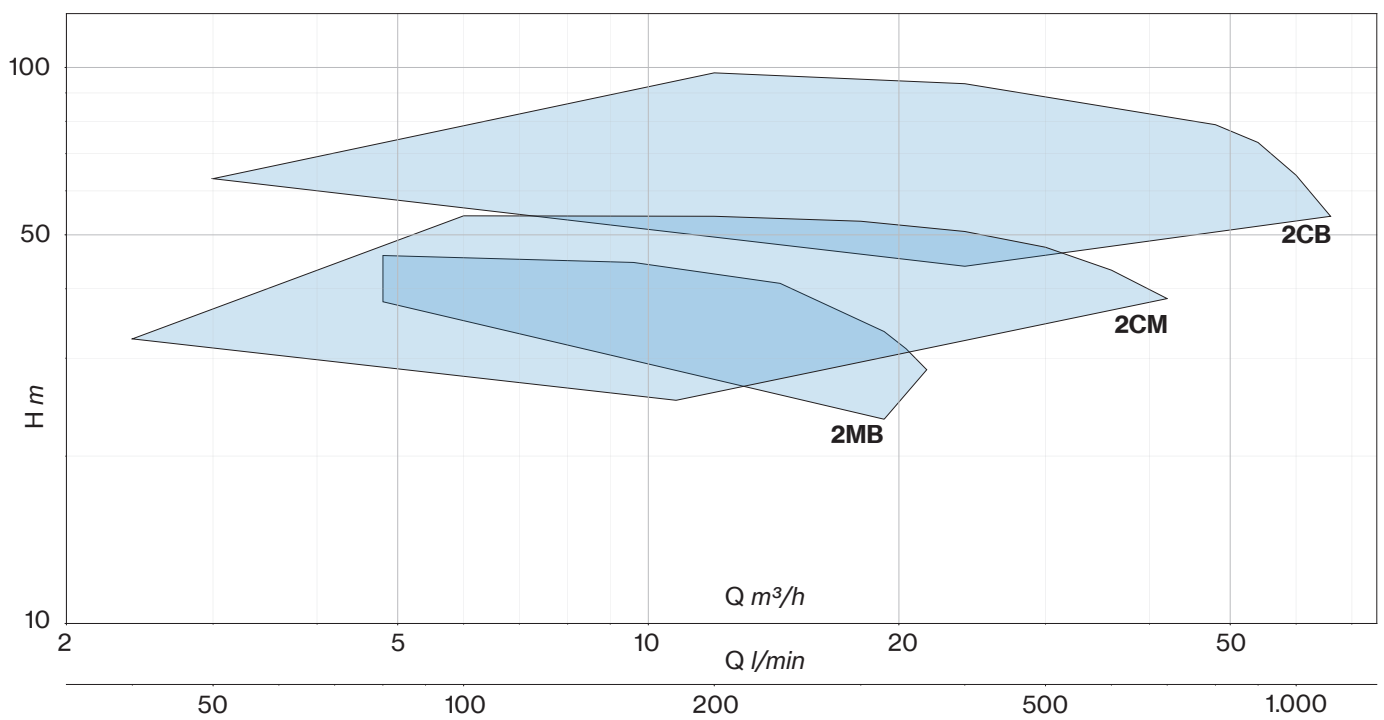

QUICK SELECTION

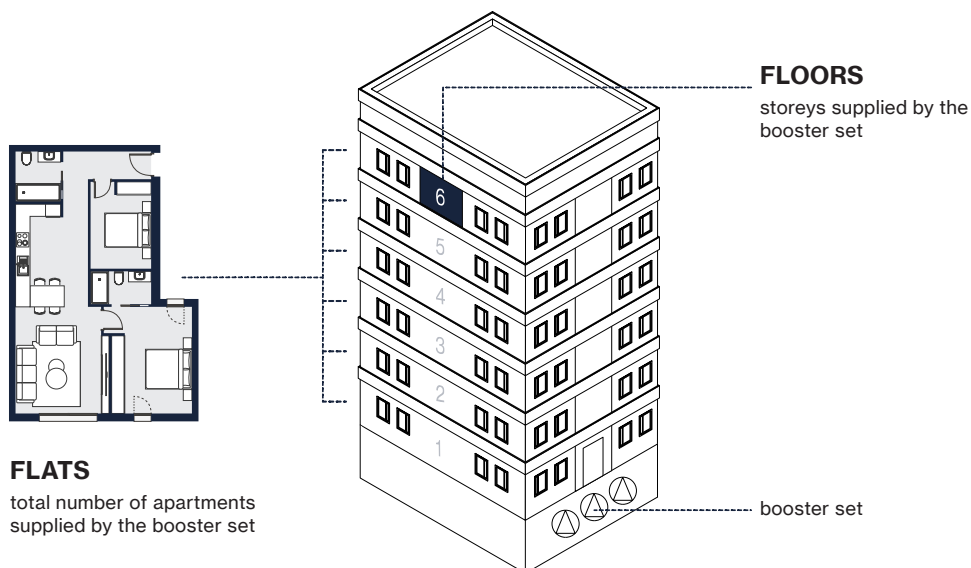

FLATS		FLOORS	CM series	MB series	CB series
1 duty and 1 standby pumps	2 duty pumps				
1	2-3	1-2 3	2CM_100_ -	-	- 2CB_100_
2-3	4-6	1-2	2CM_164_	-	2CB_100_
		3	2CM_164_	-	2CB_160_
		4-5	2CM_214_	-	2CB_160_
		6	2CM_314_	-	2CB_210_
4-5	7-13	7	-	-	2CB_310_
		1-3	2CM_164_	2MB_150_	2CB_160_
		4	2CM_214_	2MB_200_	2CB_160_
		5	2CM_214_	2MB_300_	2CB_210_
6-8	14-20	6	2CM_314_	-	2CB_310_
		1-2	2CM_214_	2MB_150_	2CB_160_
		3	2CM_214_	2MB_200_	2CB_160_
		4	2CM_214_	2MB_300_	2CB_210_
9-14	21-32	5	2CM_314_	-	2CB_310_
		1-2	-	2MB_200_	2CB_210_
		3-4	-	2MB_300_	2CB_210_
		5-6	-	-	2CB_310_
15-28	33-56	7-9	-	-	2CBT_400_
		10-12	-	-	2CBT_600_
		1-4	2CMT_400_	2MB_300_	-
		5-6	2CMT_550_	-	-
15-28	33-56	7-8	-	-	2CBT_600_
		9-11	-	-	2CBT_751_
		12-13	-	-	2CBT_900_



PERFORMANCE

TARGET (2 pumps)		MODEL				P2 NOMINAL		Q (m³/h - l/min)												
		FIXED SPEED		VARIABLE SPEED				0 2,4 4,8 7,2 9,6 10,8 13,2 14,4 15,6												
		1- 230V	3- 400V	EPIC	EPIC-A			0 40 80 120 160 180 220 240 260												
l/min	bar			1- 230V-in 3- 230V-out	3- 400V-in 3- 400V-out	HP (×2)	kW (×2)	H (m)												
100	3	-	-	2CMT/E100	2CMT/A100-304	1	0,74	33,0	32,5	31,5	29,6	26,8	25,2							
150	3,5	2CMT164	2CMT164	2CMT/E164	2CMT/A164-304	2	1,5	39,4	39,1	38,6	37,2	35,2	33,8	27,2						
200	4	2CMT214	2CMT214	-	2CMT/A214-306	2,5	1,85	46,3	45,9	45,5	44,1	42,1	41,1	38,2	35,5					
	4,5	2CMT314	2CMT314	-	2CMT/A314-306	3	2,2	53,2	52,7	52,1	50,8	48,8	47,6	45,0	42,9	39,2				

TARGET (2 pumps)		MODEL				P2 NOMINAL		Q (m³/h - l/min)												
		FIXED SPEED		VARIABLE SPEED				0 6 12 18 24 30 36 42												
		1- 230V	3- 400V	EPIC	EPIC-A			0 100 200 300 400 500 600 700												
l/min	bar			1- 230V-in 3- 230V-out	3- 400V-in 3- 400V-out	HP (×2)	kW (×2)	H (m)												
400	4	-	2CMT400	-	2CMT/A400-309	4	3	45,1	45,2	44,9	43,4	40,9	37,4	32,5						
500	4,5	-	2CMT550	-	2CMT/A550-314	5,5	4	54,1	54,1	54,0	52,9	50,7	47,5	43,2	38,4					

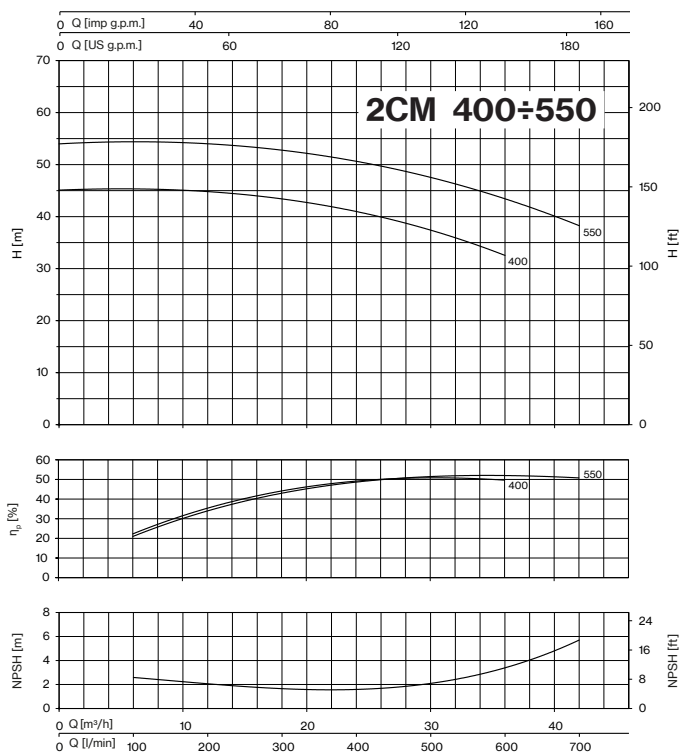
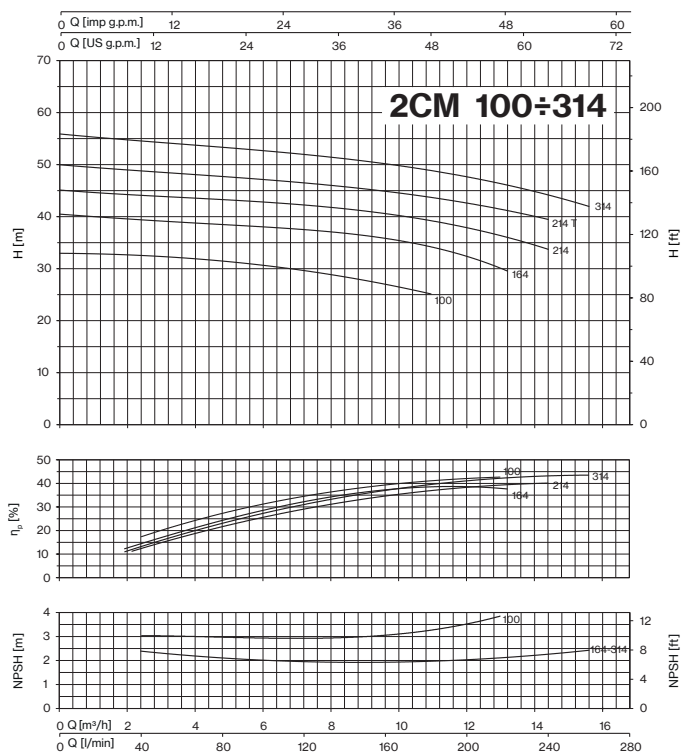

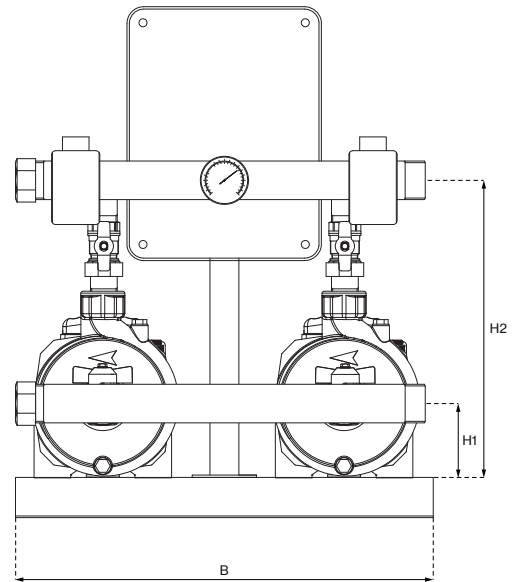
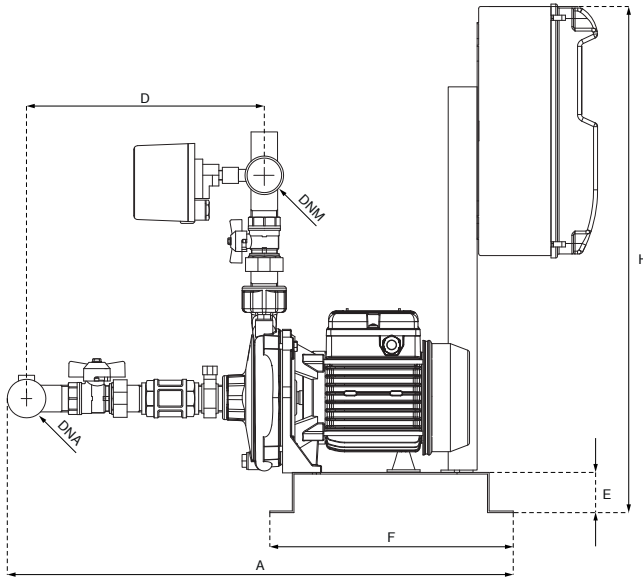

EPIC-A mounted on a skid rod for power ratings above 4 HP

MODEL				P1		In			Required tank for v.s.	DIMENSIONS										WEIGHT	
FIXED SPEED		VARIABLE SPEED		1~	3~	1~ 230V	3~ 400V	3~ 230V		A	B	D	E	F	H	H1	H2	DNA	DNM	f.s.	v.s.
1~	3~	EPIC	EPIC-A																		
-	-	2CMT/E100	2CMT/A100-304	-	1,7	-	2	3,5	2x 8	641	520	311	50	300	633	97	372	1" 1/2 G	-	49	54
2CM164	2CMT164	2CMT/E164	2CMT/A164-304	1,8	1,8	8,2	3,7	6,4	2x 8	648	520	325	50	300	633	115	423	1" 1/2 G	-	74	79
2CM214	2CMT214	-	2CMT/A214-306	2,3	2,2	10,4	4,4	-	2x 8	648	520	325	50	300	633	115	423	2" G	-	72	77
2CM314	2CMT314	-	2CMT/A314-306	2,80	2,6	13	5,2	-	2x 8	648	520	325	50	300	633	115	423	2" G	-	75	80
-	2CMT400	-	2CMT/A400-309	-	3,7	-	6,7	-	2x 20	849	615	378	60	380	633	133	515	3" G	2" 1/2 G	115	120
-	2CMT550	-	2CMT/A550-314	-	4,9	-	9	-	2x 20	849	615	378	60	380	633	133	515	3" G	2" 1/2 G	116	136

f.s. : fixed speed
v.s. : variable speed

