

Multi-stage centrifugal pumps, horizontal and self-priming, particularly suitable for constructing small and medium sized pressurisation systems; able to suck liquids mixed with air.

### Construction features

<b>Pump body</b>	cast iron
<b>Motor bracket</b>	cast iron
<b>Impeller</b>	Noryl®
<b>Mechanical seal</b>	ceramic-graphite-NBR
<b>Motor shaft</b>	stainless steel AISI 416
<b>Liquid temperature</b>	0 - 50 °C
<b>Operating pressure</b>	max 11 bar

### Motor

	3- 230/400V - 50Hz
<b>2 poles induction motor</b>	1- 230V - 50Hz (with thermal protection)
<b>Insulation class</b>	F
<b>Protection degree</b>	IPX4

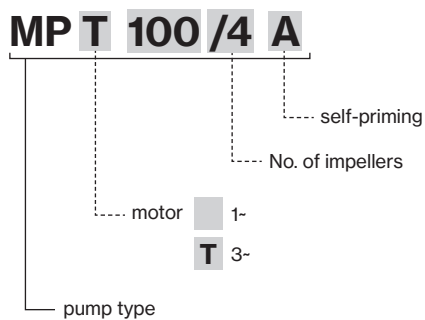

TYPE	LOTS			
	TRUCK		CONTAINER	
	PALLET (cm)	N° pumps	PALLET (cm)	N° pumps
MP/A	80×120×150	48	80×120×190	64

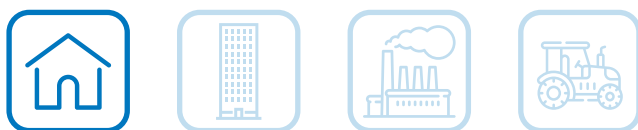

# MP/A

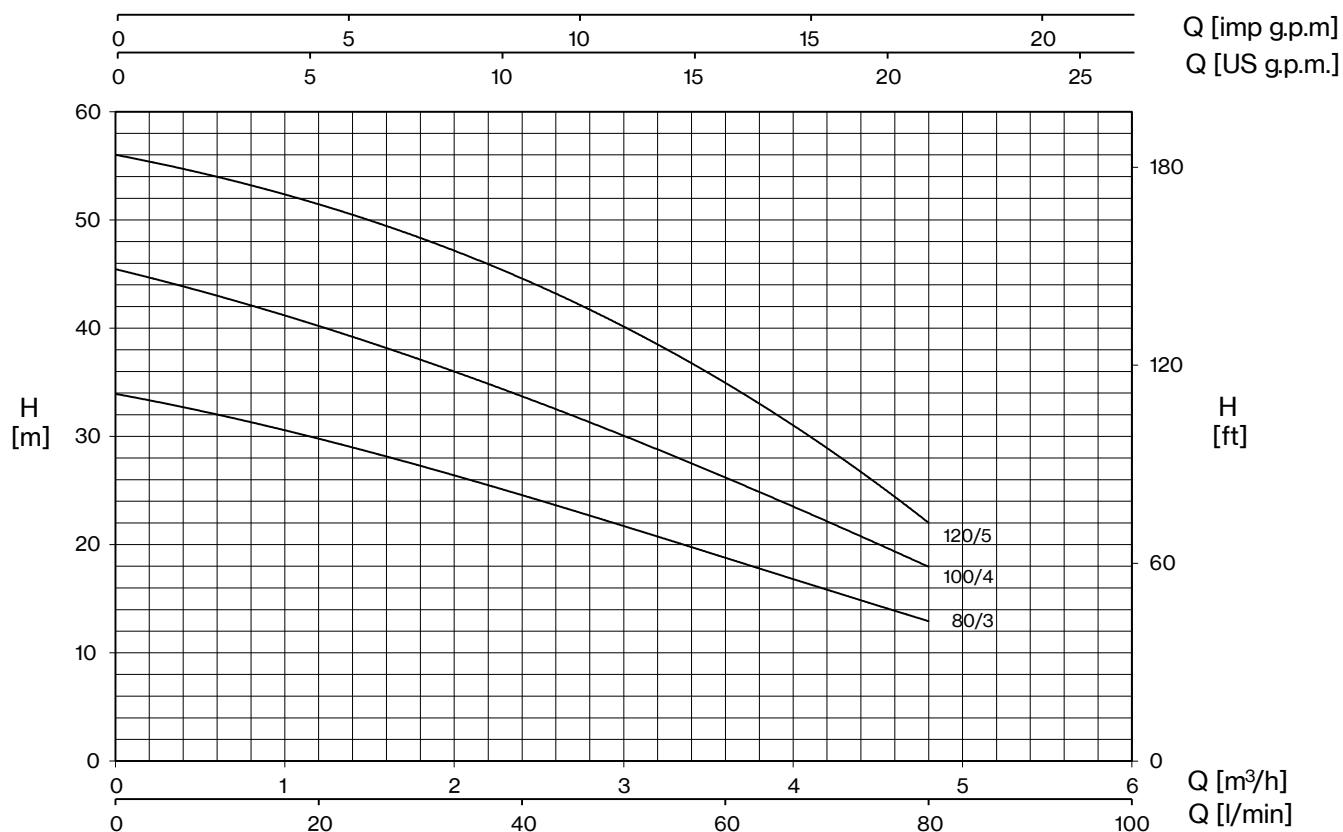

TYPE - 50 Hz		P2		P1		CURRENT		Q (m³/h - l/min)				
1~	3~			1~	3~	1~ 230V	3~ 400V	0	1,2	2,4	3,6	4,8
		HP	kW	kW		A		H (m)				
								0	20	40	60	80
MP 80/3 A	MPT 80/3 A	0,8	0,59	0,83	0,88	3,8	1,6	34,0	29,5	25,0	18,5	13,0
MP 100/4 A	MPT 100/4 A	1	0,74	1,07	1,1	5,0	1,9	45,5	40,0	34,0	26,0	18,0
MP 120/5 A	MPT 120/5 A	1,2	0,88	1,27	1,33	6,1	2,3	56	51,5	44,5	35,0	22,0

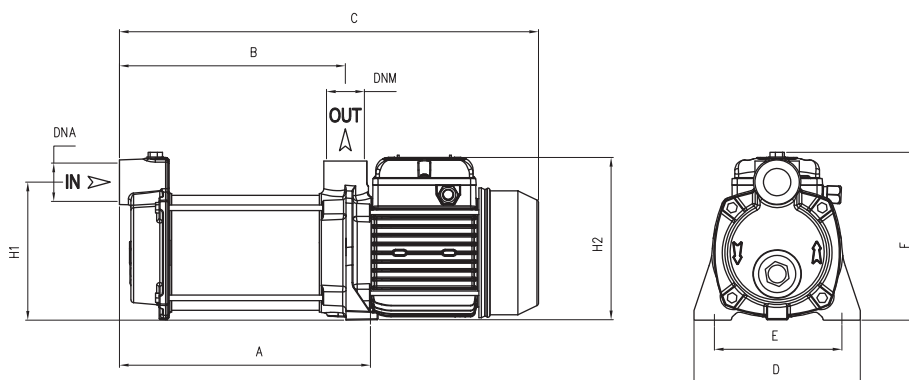

TYPE		DIMENSIONS (mm)													
~1	~3	A	B	C	D	E	F	H1	H2	DNA	DNM	I	L	M	Kg
MP 80/3 A	MPT 80/3 A	245	224	425	180	140	185	150	175			440	200	215	14
MP 100/4 A	MPT 100/4 A	270	240	450	180	140	185	150	175	1" G	1" G	500	200	215	15,5
MP 120/5 A	MPT 120/5 A	295	264	475	180	140	185	150	175			500	200	215	16

