

ULTRA SV/SL/SLX

Multistage Vertical

Stainless steel multistage vertical pumps. Pumping of clean non-loaded fluids, pressurizing system, irrigation, drinking and glycol water, water treatment, food industry, heating and air conditioning, washing system.



ULTRA SV



ULTRA 3-5-7 SL



ULTRA 9-18 SL



ULTRA SLX



Construction features

Pump body	cast iron (SV/SL); stainless steel AISI 304 (SLX)
Motor bracket	cast iron
Impellers, diffusers, shell, motor shaft	stainless steel AISI 304
Mechanical seal	ceramic-graphite-EPDM graphite-silicon carbide-EPDM
Intermediate shaft guiding stage bush	ceramic-tungsten carbide
Ambient temperature	max 40 °C
Liquid temperature	+5 ÷ 90 °C (SV) -15 ÷ 110 °C (SL/SLX)
Max operating pressure	8 bar ≤ 4 impellers; 14 bar ≥ 5 impellers
Pump body gasket	EPDM

Motor

	3- 220/380V - 60Hz
2 poles induction motor	1- 220V - 60Hz (with thermal protection up to 1,85 kW)
Insulation class	F
Protection degree	IPX4 IPX5 ≥ 4,5 HP

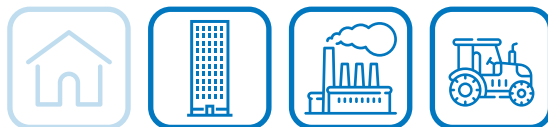

U 3 S V - 120 / 4 T

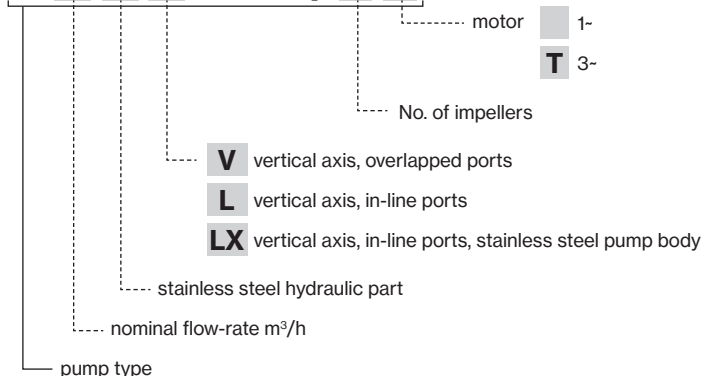

ULTRA 3 SV/SL/SLX

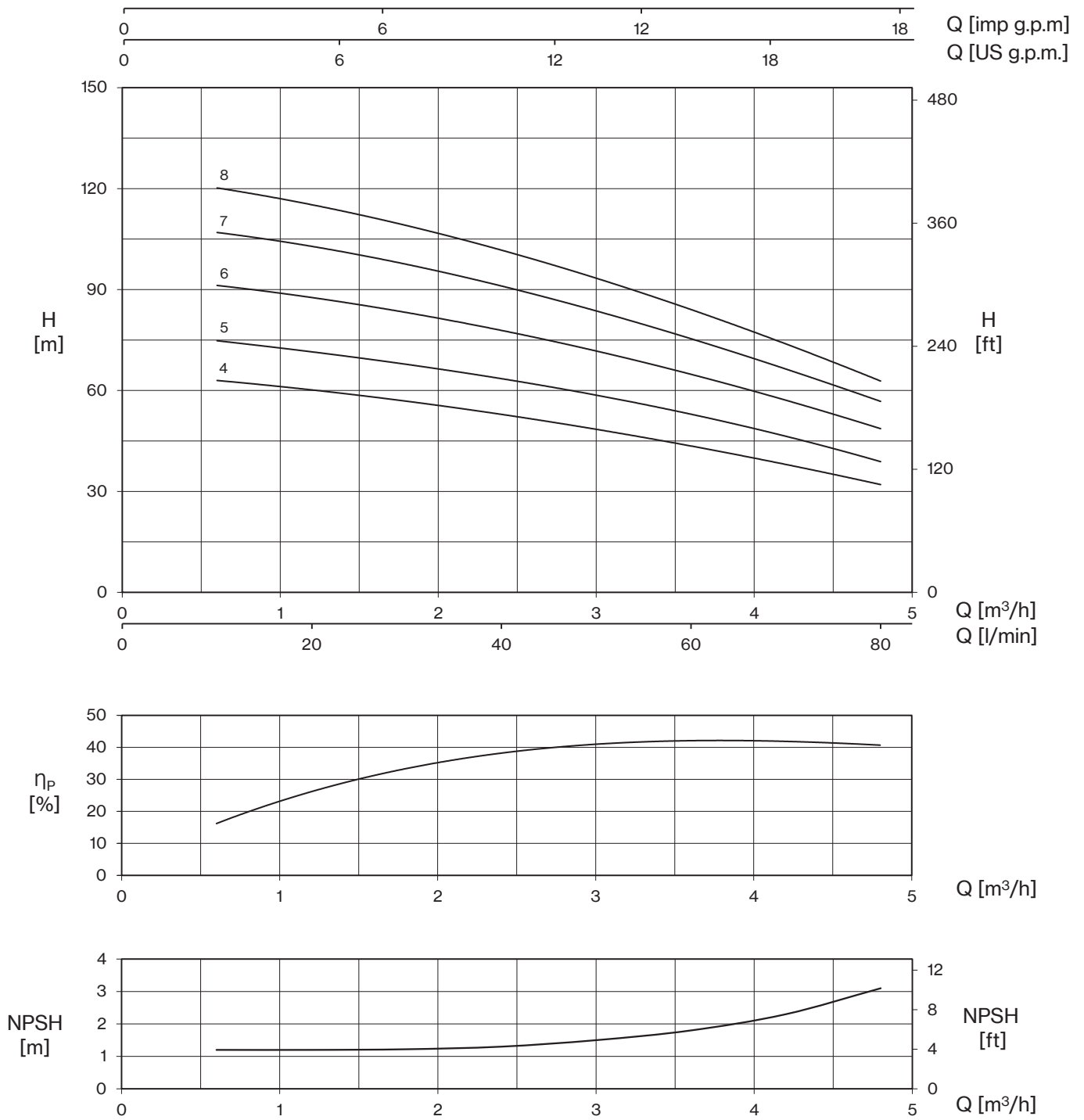

TYPE - 60 Hz		P2		P1		CURRENT		Q (m³/h - l/min)								
1~	3~			1~	3~	1~ 220V	3~ 380V	0	0,6	1,2	1,8	2,4	3	3,6	4,2	4,8
		HP	kW	kW		A		H (m)								
U 3...-120/4	U 3...-120/4T	1,2	0,9	1,3	1,3	6,2	2,6	64,6	62,9	60,3	56,9	52,7	48,6	43,2	38,4	31,9
U 3...-150/5	U 3...-150/5T	1,8	1,3	1,6	1,6	7,7	3,4	76,9	74,8	71,5	67,8	63,4	58,8	52,8	46,5	38,8
U 3...-200/6	U 3...-200/6T	1,8	1,3	2,0	1,9	9,2	3,8	93,6	91,3	87,5	83,2	77,7	72,1	64,5	57,1	48,7
U 3...-250/7	U 3...-250/7T	2,5	1,84	2,3	2,1	10,8	4,1	109,9	107,0	102,7	97,6	90,9	84,1	75,0	66,5	56,8
U 3...-300/8	U 3...-300/8T	3	2,2	2,7	2,5	13,5	4,9	123,4	120,3	115,0	109,0	101,7	93,7	83,8	73,8	62,9



ULTRA 5 SV/SL/SLX

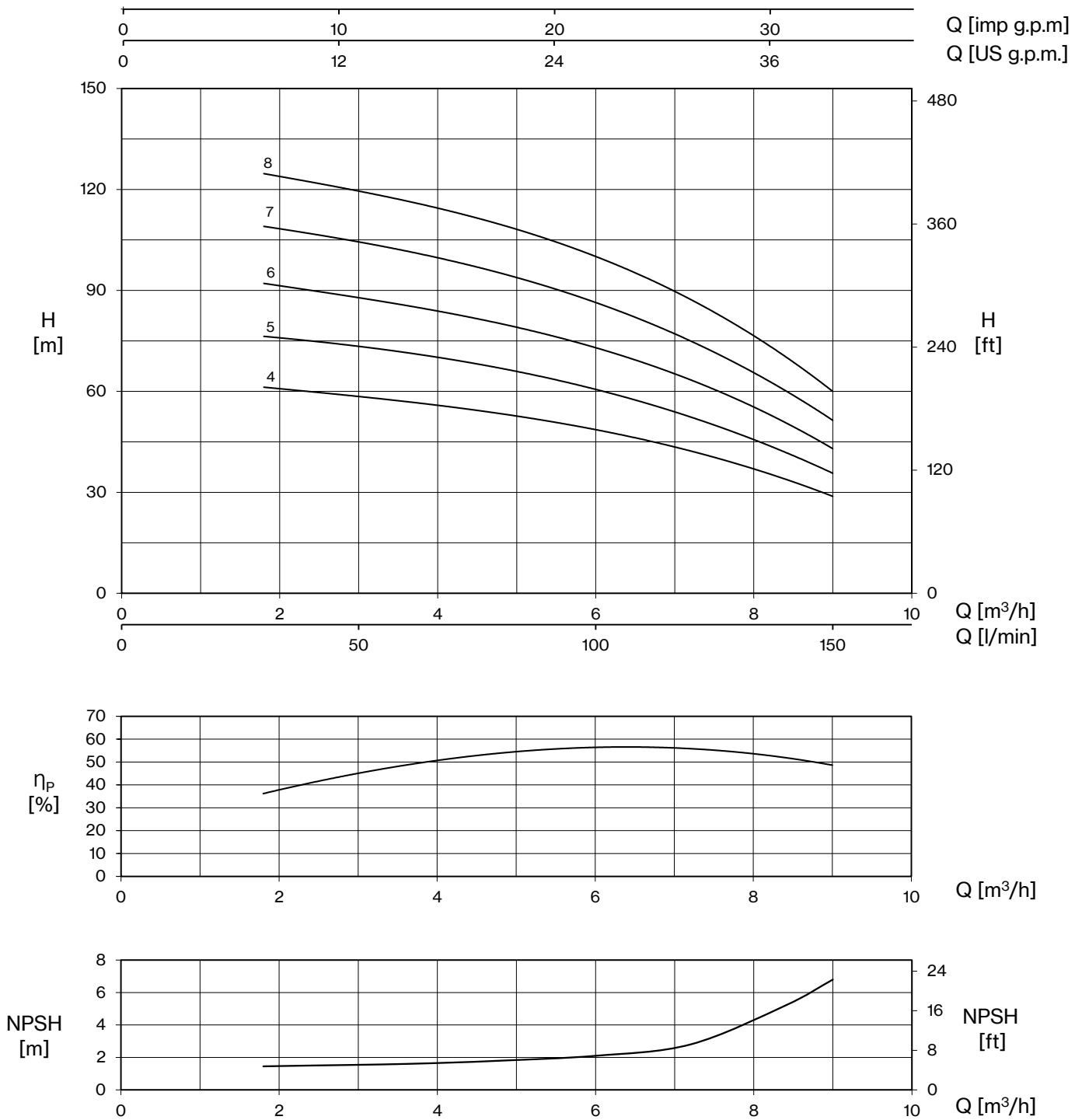

TYPE - 60 Hz		P2		P1		CURRENT		Q (m³/h - l/min)									
1~	3~			1~	3~	1- 220V	3- 380V	0	1,8	2,4	3,6	4,2	4,8	6	7,2	8,4	9
		HP	kW	kW		A		H (m)									
U 5...-180/4	U 5...-180/4T	1,8	1,3	1,9	1,8	8,9	3,6	64,3	61,1	60,0	57,0	55,5	53,1	48,3	42,4	34,2	28,6
U 5...-250/5	U 5...-250/5T	2,5	1,84	2,4	2,2	11,1	4,3	80,2	76,4	74,9	71,2	70,2	66,5	60,5	52,4	41,9	35,7
U 5...-300/6	U 5...-300/6T	3	2,2	2,9	2,6	14,5	5,1	96,6	92,1	89,7	85,7	83,1	79,8	72,7	63,6	51,0	42,8
-	U 5...-350/7T	3,5	2,57	-	3,1	-	5,9	113,6	109,1	106,7	101,6	99,2	94,7	86,3	75,1	60,2	51,4
-	U 5...-400/8T	4	3	-	3,5	-	6,8	129,6	124,6	122,3	116,6	113,7	109,1	99,8	87,9	69,9	60,1



ULTRA 7 SV/SL/SLX

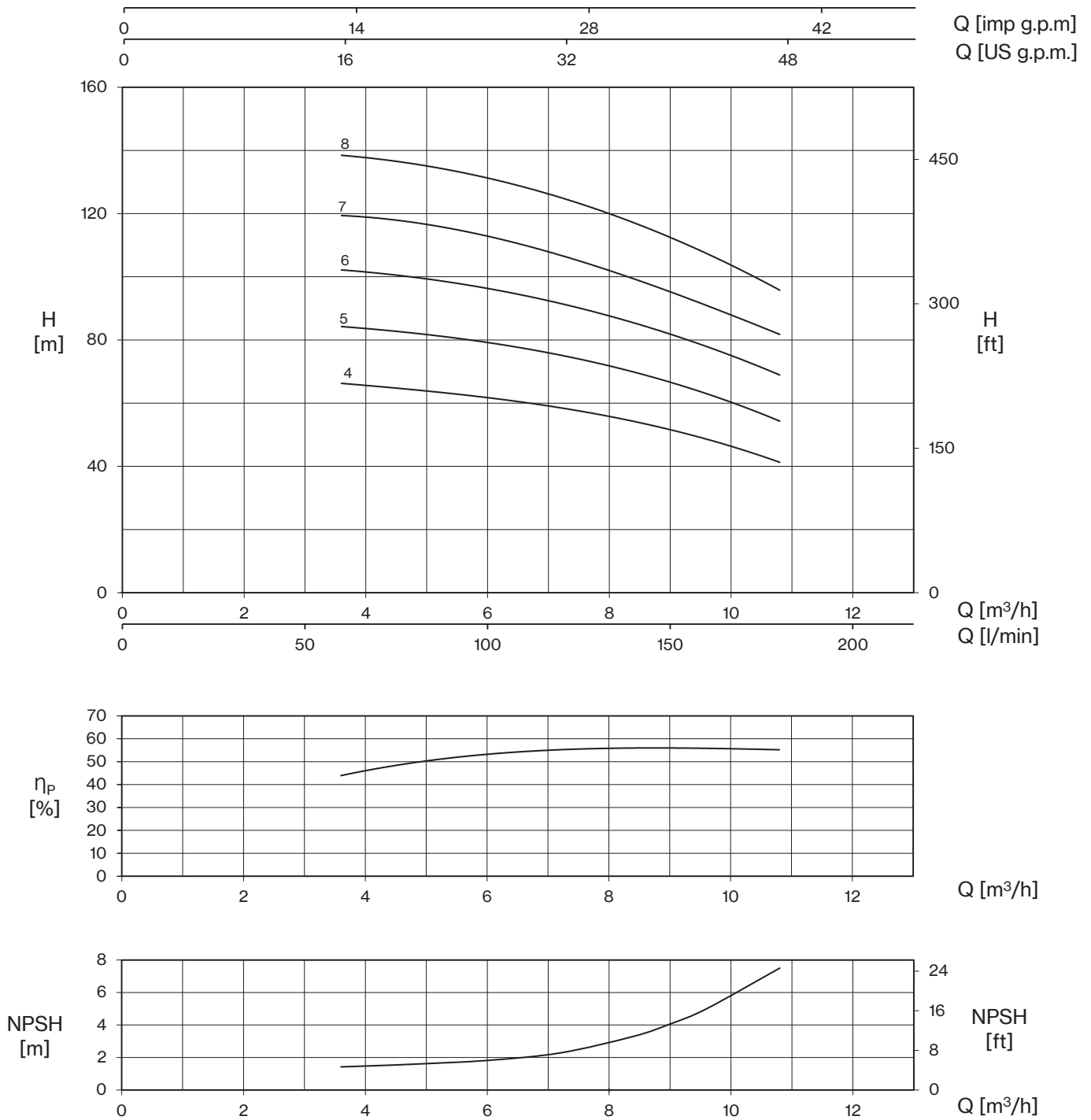

TYPE - 60 Hz		P2		P1		CURRENT		Q (m³/h - l/min)									
1~	3~			1~	3~	1~	3~	0	3,6	4,2	4,8	6	7,2	8,4	9	9,6	10,8
		HP	kW			kW	A	0	60	70	80	100	120	140	150	160	180
U 7...-300/4	U 7...-300/4T	3	2,2	3,0	2,8	15,1	5,3	67,3	66,1	65,4	64,4	61,7	58,3	54,2	51,7	48,7	41,2
-	U 7...-400/5T	4	3	-	3,5	-	6,8	85,1	84,3	83,2	82,3	79,1	75,2	69,9	66,6	62,9	54,3
-	U 7...-450/6T	4,5	3,37	-	4,3	-	7,9	102,7	102,2	101,2	99,8	96,1	91,7	85,6	81,9	77,6	69,0
-	U 7...-550/7T	5,5	4	-	5,1	-	9,5	120,7	119,6	118,5	116,9	112,7	107,2	99,8	95,2	90,2	82,0
-	U 7...-750/8T	7,5	5,5	-	5,9	-	11,2	138,2	138,5	137,3	135,6	131,1	125,2	117,5	112,5	106,8	96,0



ULTRA 9 SV/SL/SLX

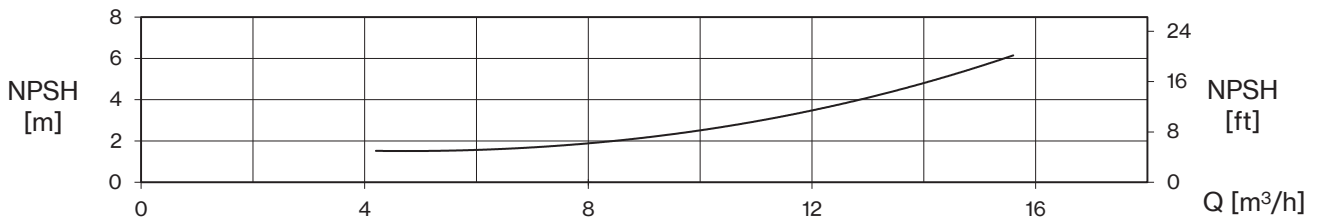
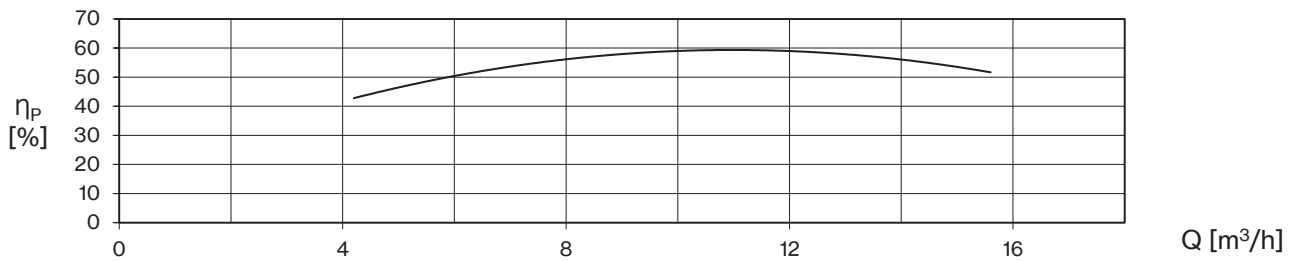
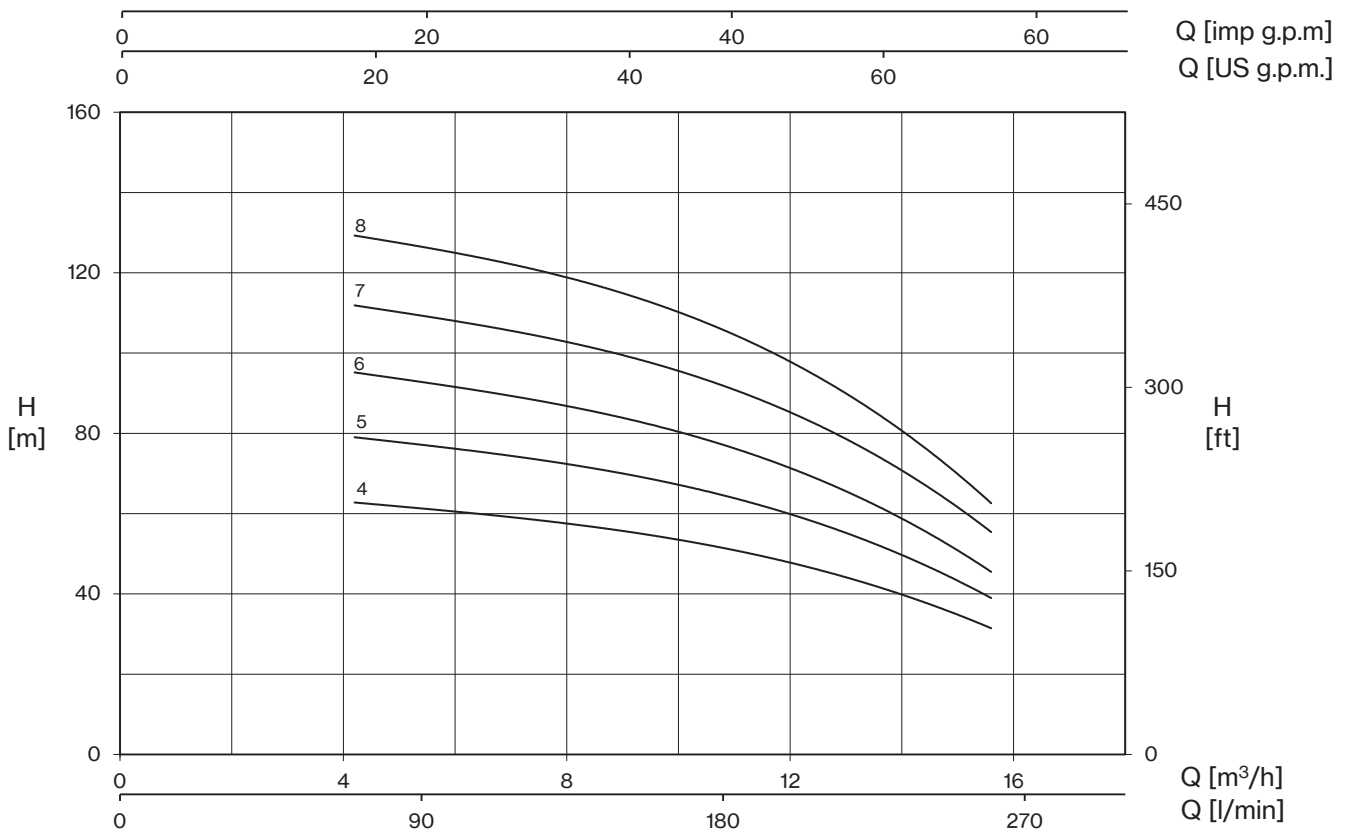

TYPE - 60 Hz		P2		P1		CURRENT		Q (m³/h - l/min)									
1~	3~			1~	3~	1~ 220V	3~ 380V	0	4,2	6	8,4	9,6	11,4	12	13,2	14,4	15,6
		HP	kW	kW		A		H (m)									
U 9...-350/4	U 9...-350/4T	3,5	2,57	3,3	3,2	16,1	6,0	66,5	62,6	60,7	56,7	54,3	49,7	47,9	43,5	37,8	31,5
-	U 9...-400/5T	4	3	-	3,8	-	7,2	83,6	78,9	76,4	71,3	68,2	62,5	60,0	54,1	47,0	39,1
-	U 9...-450/6T	4,5	3,37	-	4,6	-	8,5	100,6	94,8	92,0	85,4	81,8	74,4	71,2	64,4	55,9	45,3
-	U 9...-550/7T	6	4,4	-	5,4	-	9,9	118,0	111,6	108,3	101,2	97,2	89,0	85,5	76,9	66,8	55,6
-	U 9...-750/8T	7,5	5,5	-	6,3	-	11,7	135,5	128,9	125,4	116,9	112,1	102,5	98,3	87,9	75,9	62,9



ULTRA 18 SV/SL/SLX

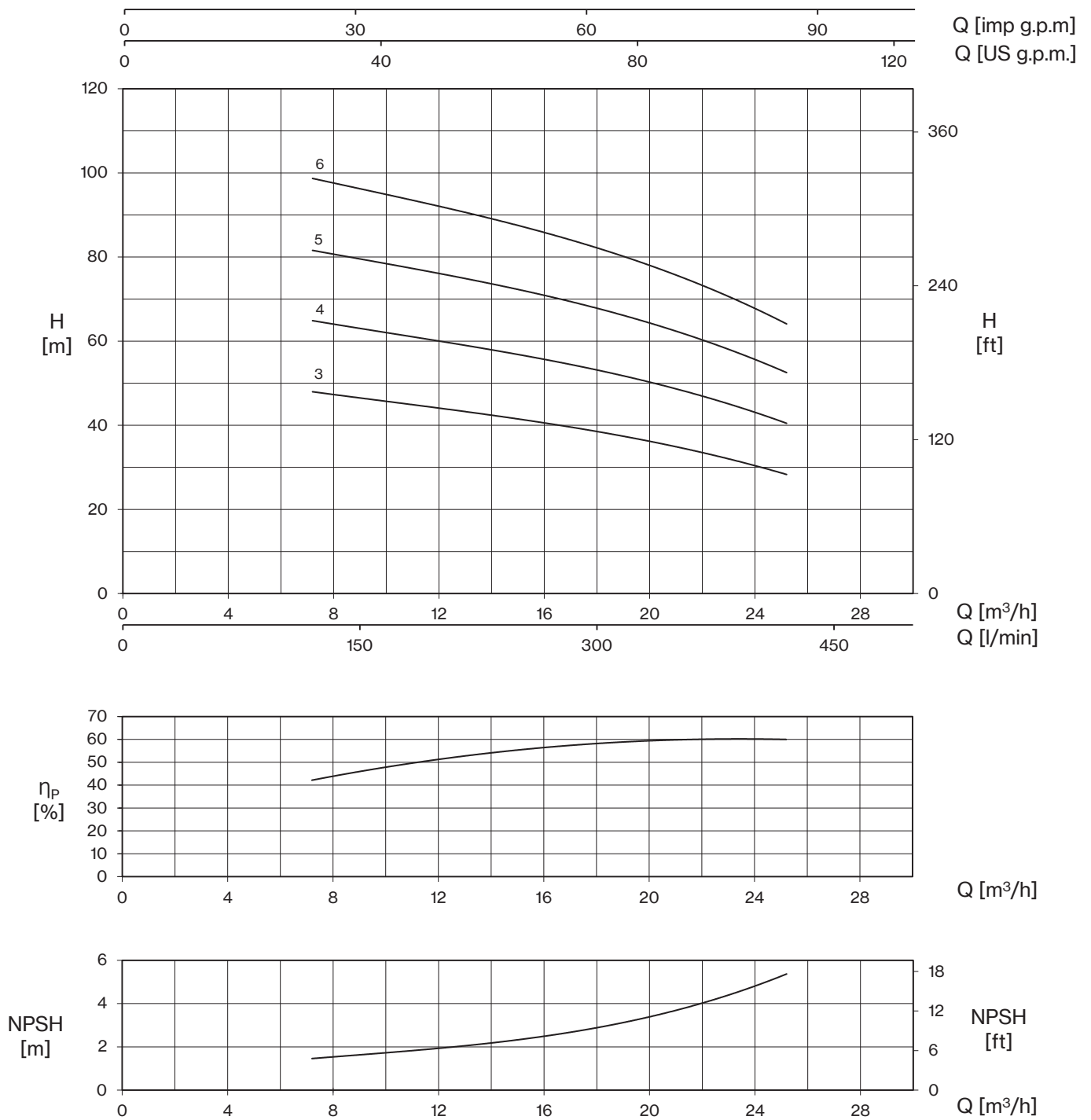

TYPE - 60 Hz	P2		P1	CURRENT 3- 380V	Q (m³/h - l/min)								
					0	7,2	9,6	12	14,4	16,8	20,4	22,8	25,2
	HP	kW	kW	A	H (m)								
U 18...-400/3T	4,5	3,37	4,0	7,4	50,2	47,8	46,1	44,1	42,0	39,6	35,9	32,6	28,1
U 18...-550/4T	6	4,4	5,5	10,1	67,2	64,6	62,6	60,1	57,4	54,5	49,9	45,9	40,2
U 18...-750/5T	7,5	5,5	6,8	12,6	84,4	81,3	79,0	76,1	73,0	69,5	63,7	58,9	52,3
U 18...-900/6T	10	7,5	8,2	15,2	101,9	98,4	95,6	92,1	88,5	84,1	77,2	71,9	63,7



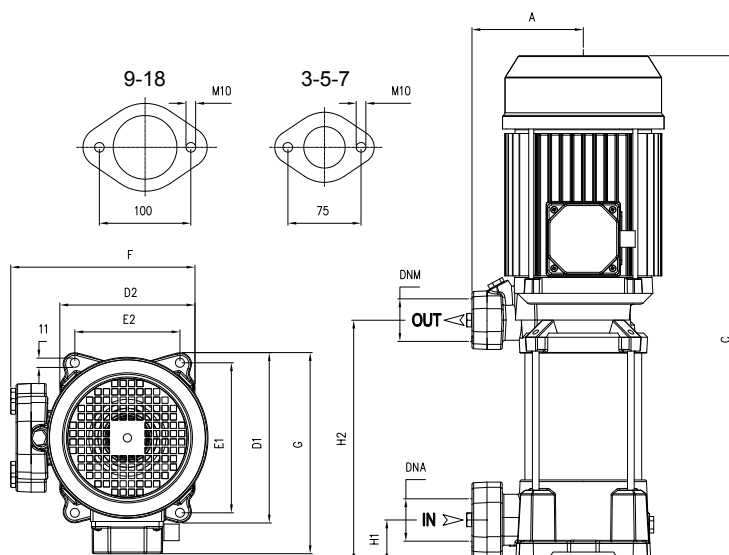

ULTRA SV



TYPE		DIMENSIONS (mm)																
1-	3-	A	C	D1	D2	E1	E2	F	G	H1	H2	DNA	DNM	I	L	M	1-	3-
U 3SV-120/4	U 3SV-120/4T	135	389	204	162	178,5	125	229	213	40	178			580	231	235	18,5	18,5
U 3SV-150/5	U 3SV-150/5T	135	473	204	162	178,5	125	229	213	40	202			580	231	235	25,5	25,5
U 3SV-200/6	U 3SV-200/6T	135	497	204	162	178,5	125	229	220	40	226	1" ¼ G	1" ¼ G	580	231	235	24,5	24,5
U 3SV-250/7	U 3SV-250/7T	135	521	204	162	178,5	125	229	220	40	250			580	231	235	23,5	24,5
U 3SV-300/8	U 3SV-300/8T	135	555	204	162	178,5	125	229	220	40	274			580	231	235	33,5	26
U 5SV-180/4	U 5SV-180/4T	135	449	204	162	178,5	125	229	220	40	178			580	231	235	23,5	25
U 5SV-250/5	U 5SV-250/5T	135	473	204	162	178,5	125	229	220	40	202			580	231	235	25	24
U 5SV-300/6	U 5SV-300/6T	135	M 552 T 497	204	162	178,5	125	229	M 228 T 220	40	226	1" ¼ G	1" ¼ G	580	231	235	32	26
-	U 5SV-350/7T	135	576	204	162	178,5	125	229	228	40	250			650	246	246	-	30
-	U 5SV-400/8T	135	600	204	162	178,5	125	229	228	40	274			650	246	246	-	33,5
U 7SV-300/4	U 7SV-300/4T	135	M 504 T 449	204	162	178,5	125	229	M 228 T 220	40	178			580	231	235	31,5	25
-	U 7SV-400/5T	135	528	204	162	178,5	125	229	228	40	202	1" ¼ G	1" ¼ G	580	231	235	-	31,5
-	U 7SV-450/6T	135	580	204	162	178,5	125	229	243	40	226			779	261	295	-	37,5
-	U 7SV-550/7T	135	604	204	162	178,5	125	229	243	40	250			779	261	295	-	42,5
-	U 7SV-750/8T	135	691	204	162	178,5	125	229	253	40	274			909	274	303	-	52
U 9SV-350/4	U 9SV-350/4T	135	528	204	162	178,5	125	229	228	40	202			580	231	235	31,5	28,5
-	U 9SV-400/5T	135	558	204	162	178,5	125	229	228	40	232			580	231	235	-	32,5
-	U 9SV-450/6T	135	616	204	162	178,5	125	229	243	40	262	1" ½ G	1" ¼ G	779	261	295	-	38
-	U 9SV-550/7T	135	646	204	162	178,5	125	229	243	40	292			779	261	295	-	43
-	U 9SV-750/8T	135	739	204	162	178,5	125	229	253	40	322			909	274	303	-	52,5
-	U 18SV-400/3T	135	536	204	162	178,5	125	229	228	50	211			580	231	235	-	32,5
-	U 18SV-550/4T	135	602	204	162	178,5	125	235	243	50	248			580	231	235	-	42
-	U 18SV-750/5T	135	703	204	162	178,5	125	255	253	50	289	2" G	1" ½ G	779	261	295	-	52
-	U 18SV-900/6T	135	740	204	162	178,5	125	255	253	50	326			779	261	295	-	59

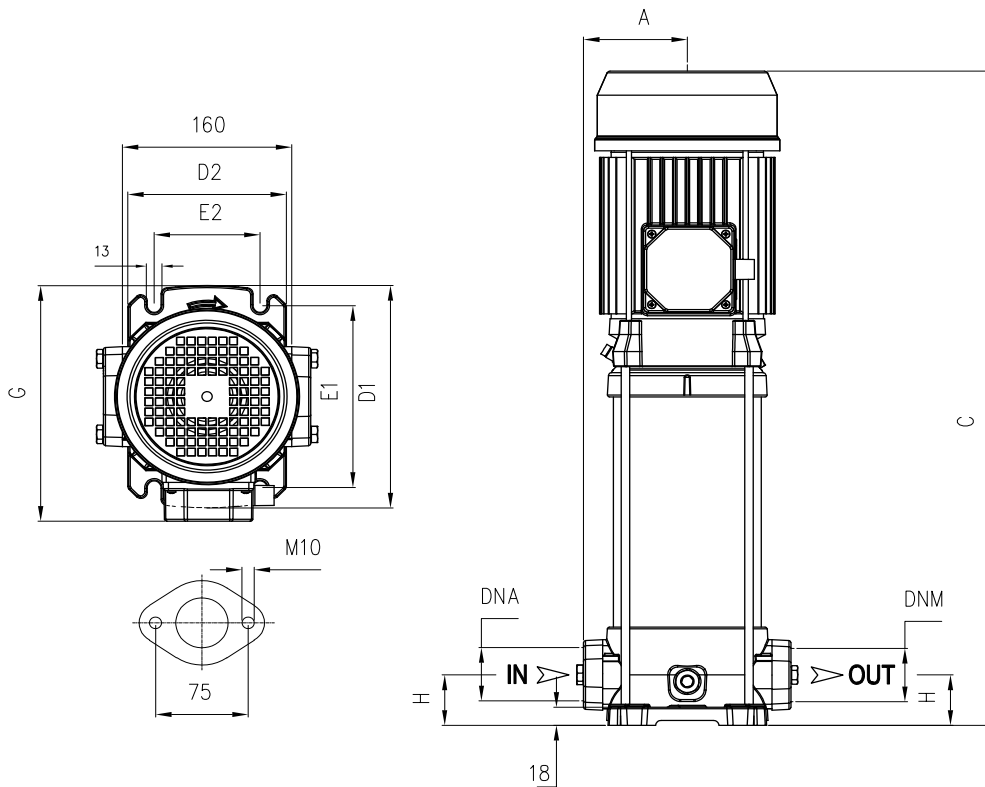



TYPE		DIMENSIONS (mm)																
		A	C	D1	D2	E1	E2	G	H	DNA	DNM				I	L	M	SL
1-	3-														1-	3-	1-	3-
U 3...-120/4	U 3...-120/4T	98	405	220	150	180	100	228	50			580	231	235	20	20	19	19
U 3...-150/5	U 3...-150/5T	98	489	220	150	180	100	228	50			580	231	235	27,5	27,5	26,5	26,5
U 3...-200/6	U 3...-200/6T	98	513	220	150	180	100	228	50	1" ¼ G	1" ¼ G	539	261	280	26,5	26,5	25,5	25,5
U 3...-250/7	U 3...-250/7T	98	537	220	150	180	100	228	50			539	261	280	25,5	26,5	24,5	25,5
U 3...-300/8	U 3...-300/8T	98	571	220	150	180	100	228	50			664	261	295	36,5	29	35,5	28
U 5...-180/4	U 5...-180/4T	98	465	220	150	180	100	228	50			580	231	235	26	27	24,5	26
U 5...-250/5	U 5...-250/5T	98	489	220	150	180	100	228	50			580	231	235	27,5	26,6	26	25
U 5...-300/6	U 5...-300/6T	98	568 T 513	220	150	180	100	236 T 228	50	1" ¼ G	1" ¼ G	539 T 580	261 T 231	280 T 235	34,5	28	33,5	27
-	U 5...-350/7T	98	592	220	150	180	100	236	50			664	261	295	-	33	-	31,5
-	U 5...-400/8T	98	616	220	150	180	100	236	50			664	261	295	-	36,5	-	35,5
U 7...-300/4	U 7...-300/4T	98	520 T 465	220	150	180	100	236 T 228	50			539 T 580	261 T 231	280 T 235	33,5	27	32,5	26
-	U 7...-400/5T	98	544	220	150	180	100	236	50			539	261	280	-	34	-	33
-	U 7...-450/6T	98	596	220	150	180	100	251	50	1" ¼ G	1" ¼ G	664	261	295	-	39	-	38
-	U 7...-550/7T	98	620	220	150	180	100	251	50			664	261	295	-	44	-	43
-	U 7...-750/8T	98	707	220	150	180	100	260	50			909	274	303	-	54	-	53

ULTRA SL/SLX

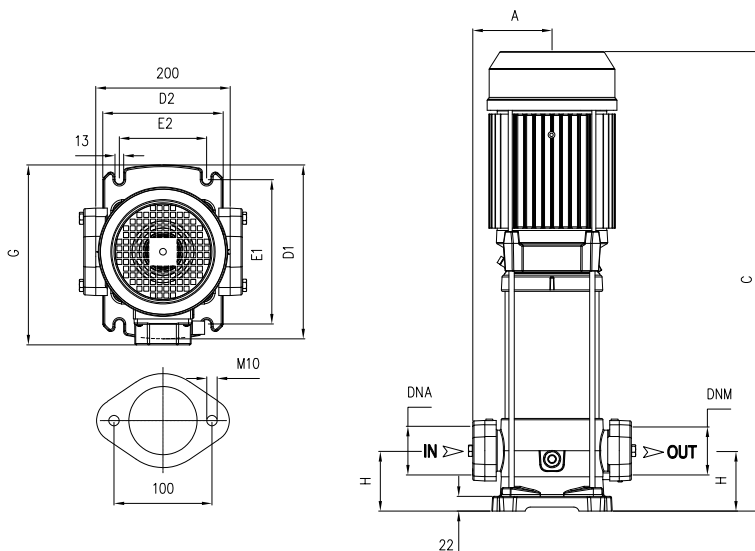

TYPE		DIMENSIONS (mm)																
1-	3-	A	C	D1	D2	E1	E2	G	H	DNA	DNM	I	L	M	SL		SLX	
U 9...-350/4	U 9...-350/4T	118	575	260	180	215	130	256	80			539	261	280	37,5	34,5	36	33
-	U 9...-400/5T	118	605	260	180	215	130	256	80			664	261	295	-	39	-	37
-	U 9...-450/6T	118	663	260	180	215	130	271	80	1" 1/2 G	1" 1/2 G	779	261	295	-	43,5	-	42
-	U 9...-550/7T	118	693	260	180	215	130	271	80			779	261	295	-	48,5	-	47
-	U 9...-750/8T	118	786	260	180	215	130	280	80			779	261	295	-	58	-	56
-	U 18...-400/3T	118	577	260	180	215	130	256	90			539	261	280	-	37,5	-	36
-	U 18...-550/4T	118	643	260	180	215	130	271	90	2" G	2" G	664	261	295	-	47,5	-	46
-	U 18...-750/5T	118	743	260	180	215	130	280	90			779	261	295	-	57	-	55,5
-	U 18...-900/6T	118	781	260	180	215	130	280	90			779	261	295	-	63,5	-	62,5

1- 110V - 60Hz	
TYPE	I (A)
U 3...-120/4	12,4

MODEL	LOTS		CONTAINER	
	TRUCK		PALLET	N°
	PALLET (cm)	N° pumps	(cm)	pumps
U 3SV-120/4-150/5	80×120×150	42	80×120×175	49
U 3SV-200/6-300/8T	80×120×150	42	80×120×175	49
U 3SV-200/6-300/8	80×120×155	30	80×120×180	35
U 5SV-180/4-350/7	80×120×150	42	80×120×175	49
U 5SV-400/8T	80×120×155	30	80×120×180	35
U 7SV-300/4-400/5T	80×120×150	42	80×120×175	49
U 7SV-450/6T-550/7T	85×110×125	20	85×110×150	24
U 7SV-750/8T	85×110×150	20	85×110×150	20
U 9SV-350/4	80×120×150	42	80×120×175	49
U 9SV-400/5	80×120×155	30	80×120×180	35
U 9SV-450/6T-550/7T	85×110×125	20	85×110×150	24
U 9SV-750/8T	85×110×150	20	85×110×150	20
U 18SV-400/3T-550/4T	80×120×150	42	80×120×175	49
U 18SV-750/5T-900/6T	85×110×125	20	85×110×150	24

MODEL	LOTS		CONTAINER	
	TRUCK		PALLET	N°
	PALLET (cm)	N° pumps	(cm)	pumps
U 3SL/SLX-120/4-150/5	85×110×150	36	85×110×170	42
U 3SL/SLX-200/6-300/8	80×120×150	30	80×120×170	35
U 5SL/SLX-180/4-250/5-300/6T	85×110×150	36	85×110×170	42
U 5SL/SLX-300/6-350/7T	80×120×150	30	80×120×170	35
U 5SL/SLX-400/8T	85×110×150	20	85×110×150	20
U 7SL/SLX-300/4T	85×110×150	36	85×110×170	42
U 7SL/SLX-300/4-400/5T	80×120×150	30	80×120×170	35
U 7SL/SLX-450/6T-550/7T	80×120×150	30	80×120×170	35
U 7SL/SLX-750/8T	85×110×150	20	85×110×150	20
U 9SL/SLX-350/4-400/5T	80×120×155	25	80×120×185	30
U 9SL/SLX-450/6T-550/7T	85×110×150	20	85×110×150	20
U 9SL/SLX-750/8T	85×110×150	20	85×110×150	20
U 18SL/SLX-400/3T-550/4T	80×120×155	25	80×120×185	30
U 18SL/SLX-750/5T-900/6T	85×110×150	20	85×110×150	20



ULTRA V-SV-L-SL-LG-SLG Serie-Mechanical seal and bearings

MECHANICAL SEAL	PUMP MODEL	SHAFT Ø		STANDARD MATERIAL	OPTIONAL
	U3-120/4, U5-180/4, U7-300/4, U9-350/4, U18-400/3, U18-550/4	14mm / S	Rotating face Stationary face Elastomer	Graphite Ceramic EPDM	SiC SiC EPDM
	U3-150/5, U3-200/6, U3-250/7, U3-300/8, U5-250/5, U5-300/6, U5-350/7, U5-400/8, U7-400/5, U7-450/6, U7-550/7, U9-400/5, U9-450/6, U9-550/7, U9-750/8	14mm	Rotating face Stationary face Elastomer	Graphite SiC EPDM	SiC SiC EPDM
	U18-750/5, U18-900/6, U18-950/7, U18-1000/8	14mm / L	Rotating face Stationary face Elastomer	Graphite Ceramic EPDM	SiC SiC EPDM
	U3-350/10, U3-400/12, U3-450/14, U3-550/16, U5-450/10, U5-550/12, U5-750/14, U7-800/10, U7-900/12, U7-1000/14, U9-800/10, U9-900/12, U9-1000/14	14mm / Balanced seal	Rotating face Stationary face Elastomer	Tungsten carbide Graphite EPDM	- - -

BEARINGS	PUMP MODEL	TYPE	
	U3-120/4	6202-ZZ	6302-ZZ C3
	U3-150/5, U3-200/6, U3-250/7, 3- U3-300/8, U 5-180/4, U5-250/5, 3- U5-300/6, 3- U7-300/4	6203-ZZ	6304-ZZ C3
	1- U3-300/8, U3-350/10, U3-400/12, 1- U5-300/6, U5-350/7, U5-400/8, 1- U7-300/4, U7-400/5, U9-350/4, U9-400/5, U18-400/3	6203-ZZ	6305-ZZ C3
	U7-450/6, U7-550/7, U9-450/6, U9-550/7, U18-550/4	6204-ZZ	6306-ZZ-C3
	U3-450/14, U3-550/16, U5-450/10	6204-ZZ	3206-ZZ C3
	U5-550/12, U5-750/14, U7-750/8, U7-800/10, U7-900/12, U9-750/8, U9-800/10, U9-900/12, U18-750/5, U18-900/6	6206-ZZ C3	3306-ZZ C3
	U7-1000/14, U9-1000/14, U18-950/7, U18-1000/8	6206-ZZ C3	3308-ZZ C3

ULTRA V/L/H + VSD

Vertical booster pump with variable speed drive

ULTRA V



EPIC / EPIC-A

IPFC

ULTRA L



EPIC / EPIC-A

IPFC

ULTRA H



IPFC

DESCRIPTION

Vertical pump of ULTRA series provided with variable speed drive EPIC, EPIC-A or IPFC. This booster pump assures a desired pressure regardless of changes on flow demand making it suitable for low or missing pressure in residential systems and industrial applications. It is required the installation of a membrane tank downstream the system.

FEATURES

- EPIC, EPIC-A or IPFC variable speed drive
- Three-phase vertical pump of ULTRA series
- Pressure sensor wired to the vsd
- Cable with plug for EPIC vsd only

FUNCTIONING

If the pressure in the network drops the pump will start and gradually speeds up to provide with the set pressure. When the water demand decreases, the pressure will rise causing the pump speed to slow down and eventually to stop the pump if demand ceases. The pump will remain on standby waiting to start at the next water demand.

SELECTION

The next table shows the vertical ULTRA pump models available for the assembly with EPIC, EPIC-A or IPFC. For pumps longer than 1.4m, IPFC is not assembled onto the motor fan cover but is supplied with a wall-mounting kit. Consult the catalog at the ULTRA series for pump specifics and characteristic curves.

U5SL /A 250/5 T -209 3×220-60

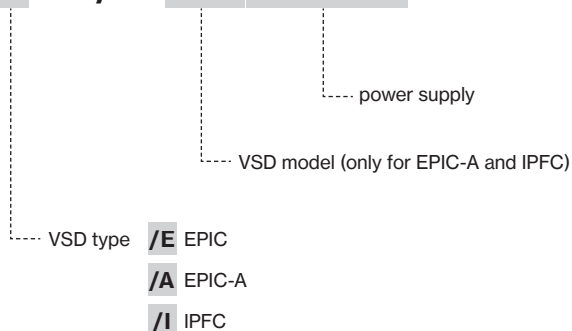

		3- PUMP						VSD TYPE						
TYPE		VERSION						Power supply						
		V	SV	L	SL SLX	LG	SL SLGX	1-220V		3-380V		3-220V		
U 3	120/4T	■	■	■	■	-	-	EPIC	IPFC 109	EPIC-A 304	IPFC 306	EPIC-A 206	IPFC 206	
	150/5T	■	■	■	■	-	-			EPIC-A 306		EPIC-A 209	IPFC 209	
	200/6T	■	■	■	-	-	-		-	-	EPIC-A 309	IPFC 309	EPIC-A 214	IPFC 214
	250/7T	■	■	■	■	-	-	-			IPFC 311	-	IPFC 218	
	300/8T	■	■	■	■	-	-	-			-	-	-	
	350/10T	-	-	-	-	-	■	-			-	-	-	
	400/12T	-	-	-	-	-	■	-			-	-	-	
	450/14T	-	-	-	-	-	■	-	-	-	-			
U 5	180/4T	■	■	■	■	-	-	EPIC	IPFC 109	EPIC-A 304	IPFC 306	EPIC-A 209	IPFC 209	
	250/5T	■	■	■	■	-	-	-	-	EPIC-A 306		EPIC-A 214	IPFC 214	
	300/6T	■	■	■	■	-	-			EPIC-A 309	IPFC 309	-	IPFC 218	
	350/7T	■	■	■	■	-	-			-	IPFC 311	-	IPFC 225	
	400/8T	■	■	■	■	-	-	-	IPFC 314	-	-			
	450/10T	-	-	-	-	-	■	-	-	-	-			
	550/12T	-	-	-	-	-	■	-	-	-	-			
	750/14T	-	-	-	-	-	■	-	-	-	-			
U 7	300/4T	■	■	■	■	-	-	-	IPFC 114	EPIC-A 306	IPFC 306	EPIC-A 214	IPFC 214	
	400/5T	■	■	■	■	-	-			EPIC-A 309	IPFC 309			
	450/6T	■	■	■	■	-	-		-	-	IPFC 311	-	IPFC 218	
	550/7T	■	■	■	■	-	-				IPFC 314	-	IPFC 225	
	750/8T	■	■	■	■	-	-				IPFC 318	-	IPFC 230	
	800/10T	-	-	-	-	-	■		-	-	-	-		
	900/12T	-	-	-	-	-	■		-	-	-	-		
	U 9	350/4T	■	■	■	■	-		-	-	-	EPIC-A 309	IPFC 309	EPIC-A 214
400/5T		■	■	■	■	-	-	-	-			IPFC 311	-	IPFC 218
450/6T		■	■	■	■	-	-					IPFC 314	-	IPFC 225
550/7T		■	■	■	■	-	-	-	-			IPFC 318	-	IPFC 230
750/8T		■	■	■	■	-	-					IPFC 325	-	-
800/10T		-	-	-	-	-	■					-	-	-
900/12T		-	-	-	-	-	■	-	-			-	-	

ULTRA+VSD

TYPE		3- PUMP							VSD TYPE				
		VERSION							Power supply				
		V	SV	L	SL SLX	LG	HS	HX	1-220V	3-380V		3-220V	
U 18	200/1T	-	-	-	-	-	-	■	IPFC 109	EPIC-A 304	IPFC 306	EPIC-A 206	IPFC 206
	400/2T	-	-	-	-	-	-	■	IPFC 114	EPIC-A 306		EPIC-A 214	IPFC 211
	400/3T	■	■	■	■	-	-	-		EPIC-A 309	IPFC309		IPFC 214
	550/3T	-	-	-	-	-	-	■					
	550/4T	■	■	■	■	-	-	-			IPFC311		IPFC 225
	750/4T	-	-	-	-	-	-	■					
	750/5T	■	■	■	■	-	-	-			IPFC 314		
	1000/5T	-	-	-	-	-	-	■					
	900/6T	■	■	■	■	-	-	-			IPFC318		IPFC 230
	950/7T	-	-	-	-	-	■	-					
	1500/6T	-	-	-	-	-	-	■					
	1500/7T	-	-	-	-	-	-	■					
	1500/8T	-	-	-	-	-	-	■			IPFC325		-
	2000/9T	-	-	-	-	-	-	■					
2000/10T	-	-	-	-	-	-	■						
2000/11T	-	-	-	-	-	-	■			IPFC330			
U 22	300/1T	-	-	-	-	-	■	■	IPFC 114	EPIC-A 306	IPFC 306	EPIC-A 209	IPFC 209
	550/2T	-	-	-	-	-	■	■			IPFC 309		IPFC 214
	750/3T	-	-	-	-	-	■	■			IPFC 311		IPFC 225
	1000/4T	-	-	-	-	-	■	■			IPFC 318		IPFC 230
	1500/5T	-	-	-	-	-	■	■			IPFC 325		
	1500/6T	-	-	-	-	-	■	■					
	2000/7T	-	-	-	-	-	■	■			IPFC 330		
	2000/8T	-	-	-	-	-	■	■					
U 35	400/1-1RT	-	-	-	-	-	■	■		EPIC-A 309		EPIC-A 214	IPFC 211
	550/1T	-	-	-	-	-	■	■			IPFC 309		IPFC 218
	750/2-2RT	-	-	-	-	-	■	■			IPFC 314		IPFC 225
	1000/2-1RT	-	-	-	-	-	■	■			IPFC 318		IPFC 230
	1500/2T	-	-	-	-	-	■	■					
	1500/3-2RT	-	-	-	-	-	■	■					
	1500/3-1RT	-	-	-	-	-	■	■			IPFC 325		
	2000/3T	-	-	-	-	-	■	■					
	2000/4-2RT	-	-	-	-	-	■	■			IPFC 330		
	2000/4-1RT	-	-	-	-	-	■	■					
U 50	750/1-1RT	-	-	-	-	-	■	■			IPFC 311		IPFC 218
	1000/1T	-	-	-	-	-	■	■			IPFC 314		IPFC 225
	1500/2-2RT	-	-	-	-	-	■	■			IPFC 325		
	1500/2-1RT	-	-	-	-	-	■	■					
	2000/2T	-	-	-	-	-	■	■			IPFC 330		
U 75	1000/1-1RT	-	-	-	-	-	■	■			IPFC 314		IPFC 225
	1500/1T	-	-	-	-	-	■	■			IPFC 325		
	2000/2-2RT	-	-	-	-	-	■	■			IPFC 330		
U 90	1500/1-1RT	-	-	-	-	-	■	■			IPFC 325		
	2000/1RT	-	-	-	-	-	■	■			IPFC 330		

