

# 10-12LM & E14 lines

## Deepwell Borehole

Submersible Multistage Centrifugal Pumps for 10", 12", and 14" Wells. These pumps are equipped with a check valve integrated into the delivery outlet. The pump motor bracket and coupling are designed in accordance with NEMA standards, ensuring reliability and compatibility. Common applications include civil and agricultural uses. All components are manufactured from stainless steel using lost wax microfusion technology. The standard material is AISI 304 stainless steel, with the following materials available upon request: AISI 316 stainless steel, Duplex steel (EN 1.4462), and AISI 904L stainless steel. The bushing bearings and wear rings are made from sand abrasion-resistant rubber, while the reverse-thrust ring is constructed from PTFE/Graphite for enhanced durability and performance.

### General operating data:

- Capacity up to 860 m<sup>3</sup>/h
- Pressure up to 540 m
- Hydraulic efficiency 10", up to 79,3%
- Hydraulic efficiency 12", up to 82,5%
- Hydraulic efficiency 14", up to 85,7%
- Powers up to 400 kW
- Rotation speed 2.900 rpm
- Maximum depth: 350 m
- Maximum quantity of sand: 100 gr/m<sup>3</sup>
- Drinking water compatibility according to DM174 MEI ≥ 0,4 (EU directive No.547/2012)
- Performance tolerance: ISO9906-3B.

### Construction features

<b>Suction and delivery outlet and NRV valve</b>	stainless steel AISI 304 (LMS) stainless steel AISI 316 (LMX - EX) Duplex EN 1.4462 (LMD - ED) Cast iron (E)
<b>Impellers and diffusers</b>	stainless steel AISI 304 (LMS) stainless steel AISI 316 (LMX - EX) Duplex EN 1.4462 (LMD - ED) Cast iron (E)
<b>Upper bushings</b>	NBR rubber
<b>Shaft pump side</b>	stainless steel AISI 304 (LMS) stainless steel AISI 316 (LMX) Duplex EN 1.4462 (LMD) stainless steel AISI 431 (E - EX - ED)
<b>Quantity of sand in the water</b>	max 100 g/m <sup>3</sup>

### Motor

<b>Asynchronous 2 pole</b>	rewindable water cooled
<b>Insulation class</b>	Y (max 30 °C) - PPC winding type F (max 50 °C) - PE2+PA or LPE winding type
<b>Protection degree</b>	IP68
<b>Liquid temperature</b>	max 30 °C (max 50 °C on request)
<b>Depth of immersion</b>	max 350 m



10LM line



12LM line



E14

# 10LM 190

50 Hz - 2900 rpm				Q									
TYPE	SUITABLE MOTOR 3- 400V		I/min	0	700	1800	2200	2600	3000	3400	3800	4000	
	P2		CURRENT	I/sec	0	11,7	30,0	36,7	43,3	50,0	56,7	63,3	66,7
	HP	kW	A	m³/h	0	42	108	132	156	180	204	228	240
10LM 190/01DR20	25	18,5	38,3	H (m)	35	34	32	30	27	24	21	16	14
10LM 190/01	30	22	45,1		42	41	38	36	34	31	28	23	21
10LM 190/02DR10	50	37	75,8		76	75	70	66	61	55	48	40	35
10LM 190/02	60	45	86,3		83	82	77	73	68	62	55	47	41
10LM 190/03DR20	75	55	106,2		104	102	95	89	82	73	62	49	42
10LM 190/03	90	66	126,0		125	124	115	109	102	93	83	70	62
10LM 190/04DR10	100	75	143,2		152	150	140	132	122	110	96	79	70
10LM 190/04	125	92	175,1		166	165	154	146	136	124	110	94	82
10LM 190/05DR10	150	110	211,0		190	188	175	165	153	138	120	99	87
10LM 190/05D	150	110	211,0		208	206	192	182	170	155	138	117	103
10LM 190/06DR10D	175	130	245,3	228	225	210	198	184	166	144	119	104	
10LM 190/06D	175	130	245,3	250	247	230	218	204	186	166	140	124	

Max Eff. % DR20 =	76,5
Max Eff. % DR10 =	77,5
Max Eff. %	77
Max kW / St. DR20 =	16
Max kW / St. DR10 =	18,5
Max kW / St.	20,8

NPSH (m)	Q=25%	Q=50%	Q=75%	Q=100%
	3,4	5	7,8	11,8

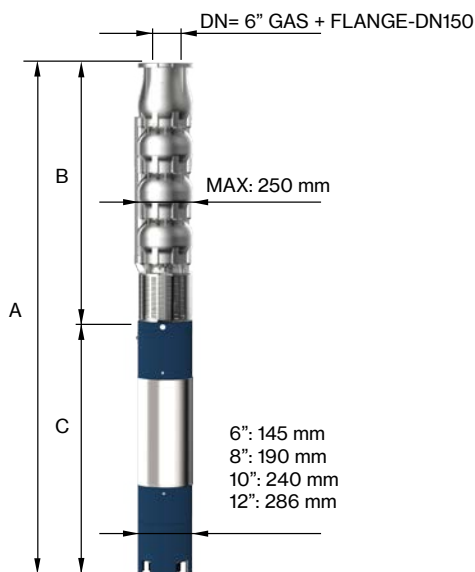

TYPE	MOTOR BRACKET	DIMENSIONS (mm)			WEIGHT (kg)	
		A	B	C	MOTOR	PUMP
10LM 190/01DR20-8	8" NEMA	1616	625	991	83	41
10LM 190/01-8		1696	625	1071	92	41
10LM 190/02DR10-8		2146	805	1341	118	56
10LM 190/02-8		1928	805	1123	178	56
10LM 190/03DR20-8		2218	985	1233	200	72
10LM 190/03-8		2287	985	1302	214	72
10LM 190/04DR10-8		2548	1165	1383	230	87
10LM 190/04-8		2748	1165	1583	270	87
10LM 190/05DR10-8		2898	1165	1733	300	87
10LM 190/05D-8		2898	1165	1733	300	87
10LM 190/06DR10D	10"	2799	1165	1634	385	87
10LM 190/06D		2799	1165	1634	385	87

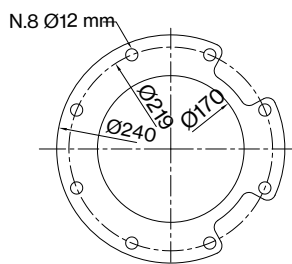

FOR COMMERCIAL TUBE  
EXTERNAL DIAMETER: 168,3 mm

"DR" : reduced-diameter impellers  
"D" Pump shaft in Duplex EN 1.4462



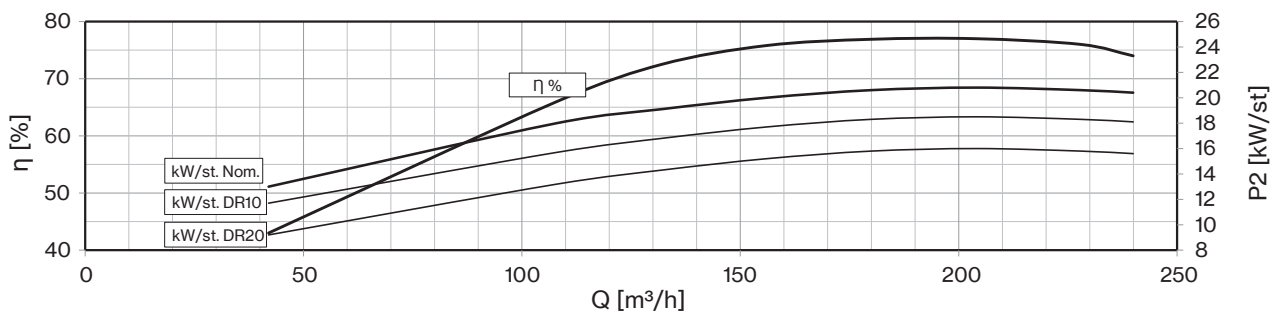
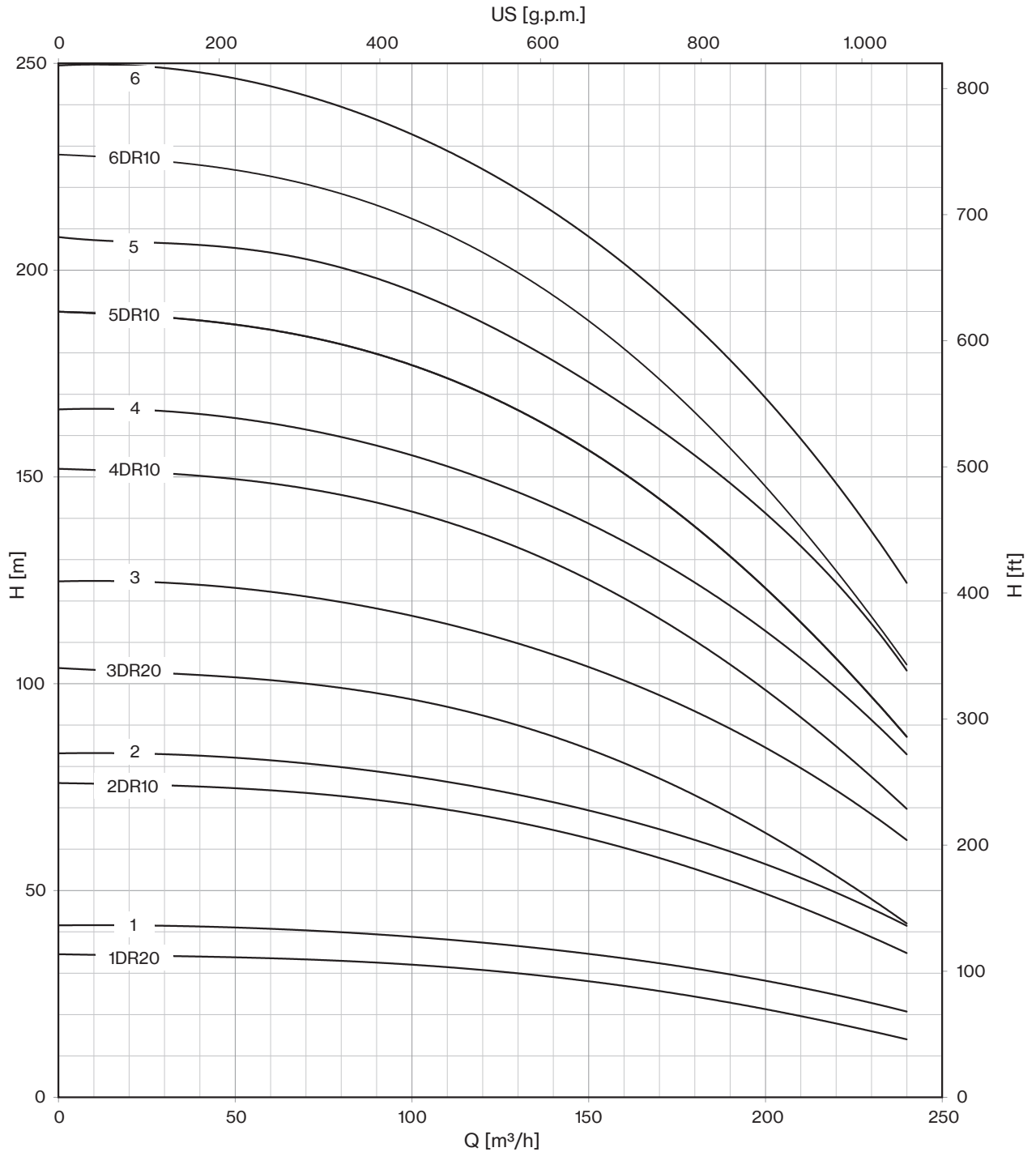

# 10LM 190

50 Hz - 2900 rpm				Q									
TYPE	SUITABLE MOTOR 3- 400V		I/min	0	700	1800	2200	2600	3000	3400	3800	4000	
	P2		CURRENT	I/sec	0	11,7	30,0	36,7	43,3	50,0	56,7	63,3	66,7
	HP	kW	A	m³/h	0	42	108	132	156	180	204	228	240
10LM 190/07DR10D	175	130	245,3	H (m)	266	263	245	231	214	193	168	139	122
10LM 190/07D	200	150	277,2		291	288	269	255	238	217	193	164	144
10LM 190/08DR10D	200	150	277,2		304	300	280	264	245	221	192	158	139
10LM 190/08D	250	185	342,2		333	330	307	291	272	248	221	187	165
10LM 190/09D	300	220	430,0		374	371	346	328	306	279	248	211	185
10LM 190/10D	300	220	430,0		416	412	384	364	340	310	276	234	206
10LM 190/11D	340	250	481,0		458	453	422	400	374	341	304	257	227

Max Eff. % DR20 =	76,5
Max Eff. % DR10 =	77,5
Max Eff. %	77
Max kW / St. DR20 =	16
Max kW / St. DR10 =	18,5
Max kW / St.	20,8

NPSH (m)	Q=25%	Q=50%	Q=75%	Q=100%
	3,4	5	7,8	11,8

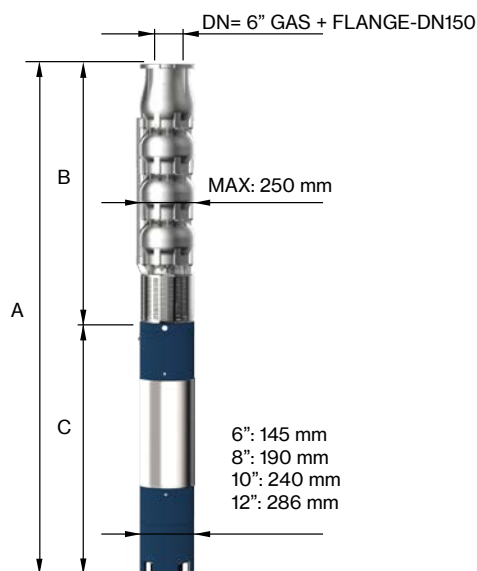

TYPE	MOTOR BRACKET	DIMENSIONS (mm)			WEIGHT (kg)	
		A	B	C	MOTOR	PUMP
10LM 190/07 DR10D	10"	3339	1705	1634	385	134
10LM 190/07D		3439	1705	1734	415	134
10LM 190/08DR10D		3619	1885	1734	415	149
10LM 190/08D		3869	1885	1984	480	149
10LM 190/09D-12	12"	4175	2065	2110	700	165
10LM 190/10D-12		4355	2245	2110	700	180
10LM 190/11D-12		4705	2425	2280	775	196

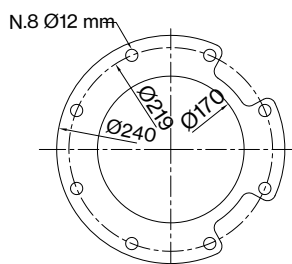

FOR COMMERCIAL TUBE  
EXTERNAL DIAMETER: 168,3 mm

"DR": reduced-diameter impellers  
"D" Pump shaft in Duplex EN 1.4462



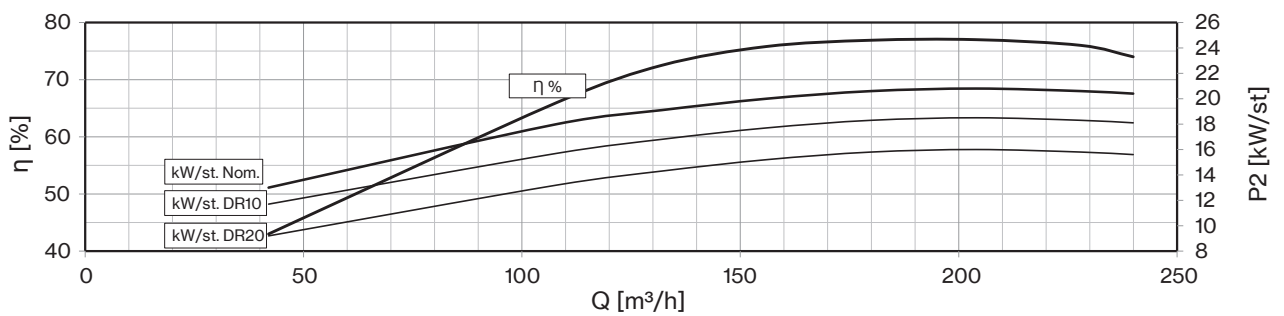
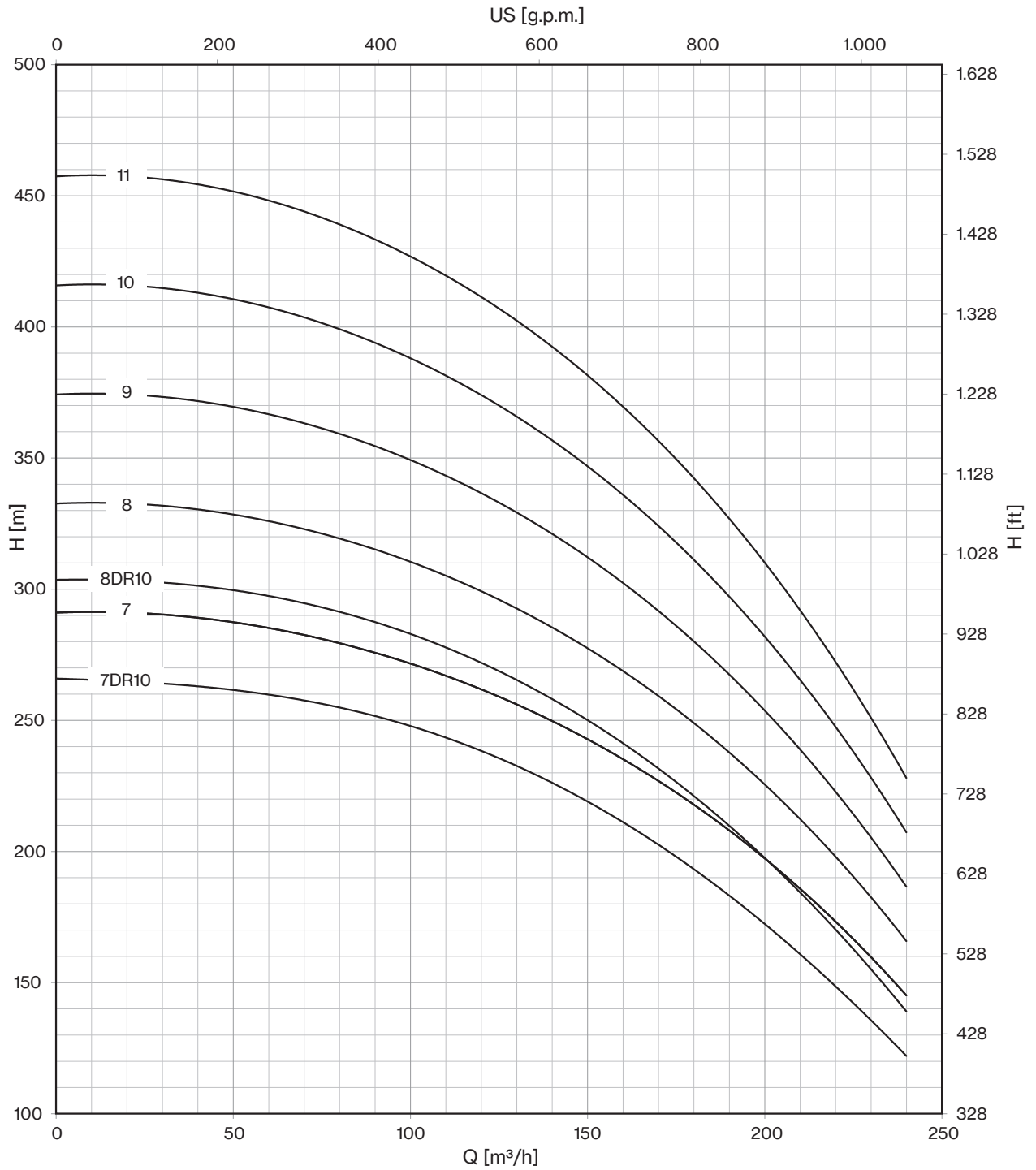

# 10LM 230

50 Hz - 2900 rpm				Q									
TYPE	SUITABLE MOTOR 3- 400V		I/min	0	800	2200	2600	3000	3400	3800	4200	4600	
	P2		CURRENT	I/sec	0	13,3	36,7	43,3	50,0	56,7	63,3	70,0	76,7
	HP	kW	A	m3/h	0	48	132	156	180	204	228	252	276
10LM 230/01DR20	25	18,5	38,3	H (m)	37	36	31	29	27	25	23	19	16
10LM 230/01	35	26	52,9		44	43	38	36	34	32	30	26	23
10LM 230/02DR20	50	37	75,8		74	71	62	58	54	50	45	38	32
10LM 230/02	75	55	106,2		88	85	75	72	68	64	59	53	46
10LM 230/03DR20	75	55	106,2		110	107	93	87	81	75	68	57	48
10LM 230/03DR10	90	66	126,0		121	116	102	98	92	86	78	68	59
10LM 230/03	100	75	143,2		131	128	113	108	102	96	89	79	69
10LM 230/04DR10	125	92	175,1		162	154	136	130	122	114	104	91	78
10LM 230/04	125	92	175,1		175	170	150	144	136	128	118	106	92
10LM 230/05DR10D	150	110	211,0		202	193	170	163	153	143	130	114	98
10LM 230/05 D	175	130	245,3		219	213	188	180	170	160	148	132	115
10LM 230/06DR10D	175	130	245,3		242	231	204	195	183	171	156	137	117
10LM 230/06D	200	150	277,2		263	255	225	216	204	192	178	159	138

Max Eff. % DR20 =	78,4
Max Eff. % DR10 =	79,5
Max Eff. %	79,2
Max kW / St. DR20 =	17,5
Max kW / St. DR10 =	19,5
Max kW / St.	22,8

NPSH (m)	Q=25%	Q=50%	Q=75%	Q=100%
	3,4	5	7,8	11,8

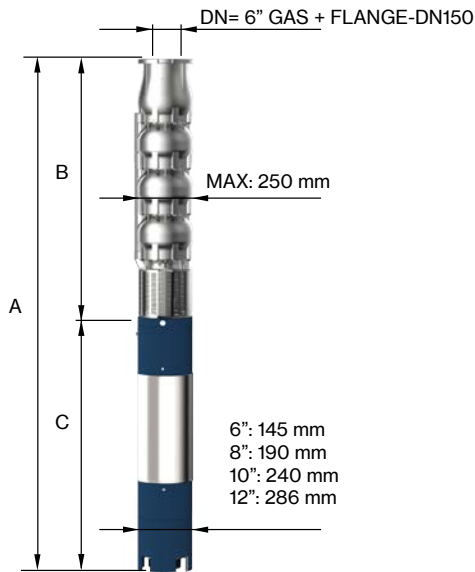

TYPE	MOTOR BRACKET	DIMENSIONS (mm)			WEIGHT (kg)	
		A	B	C	MOTOR	PUMP
10LM 230/01DR20-6	6" NEMA	1616	625	991	83	41
10LM 230/01-6		1806	625	1181	100	41
10LM 230/02DR20-6		2146	805	1341	118	56
10LM 230/02-8	8" NEMA	2038	805	1233	200	56
10LM 230/03DR20-8		2218	985	1233	200	72
10LM 230/03DR10-8		2287	985	1302	214	72
10LM 230/03-8		2368	985	1383	230	72
10LM 230/04DR10-8		2748	1165	1583	270	87
10LM 230/04-8		2748	1165	1583	270	87
10LM 230/05DR10D-8	10"	3078	1345	1733	300	103
10LM 230/05D		3078	1345	1733	300	103
10LM 230/06DR10D		3159	1525	1634	385	118
10LM 230/06D		3159	1525	1634	385	118

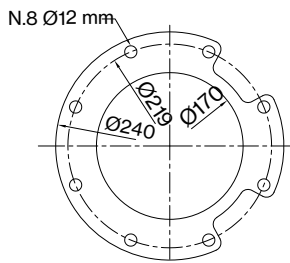

FOR COMMERCIAL TUBE  
EXTERNAL DIAMETER: 168,3 mm

"DR" : reduced-diameter impellers  
"D" Pump shaft in Duplex EN 1.4462



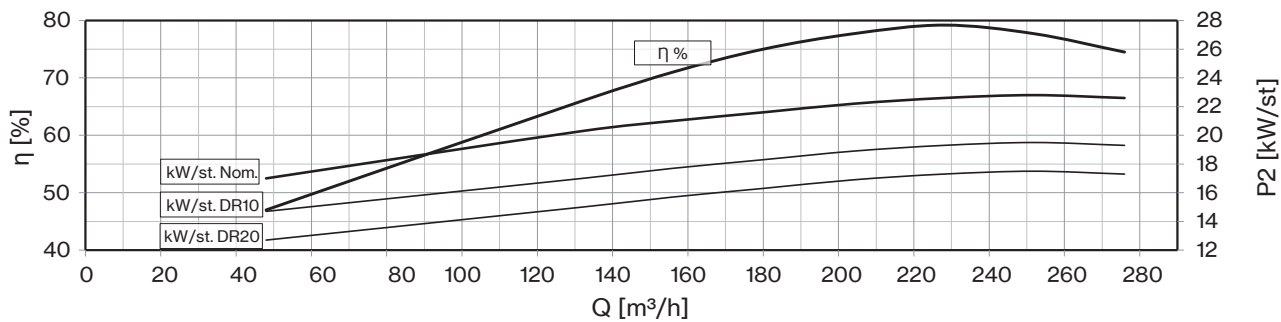
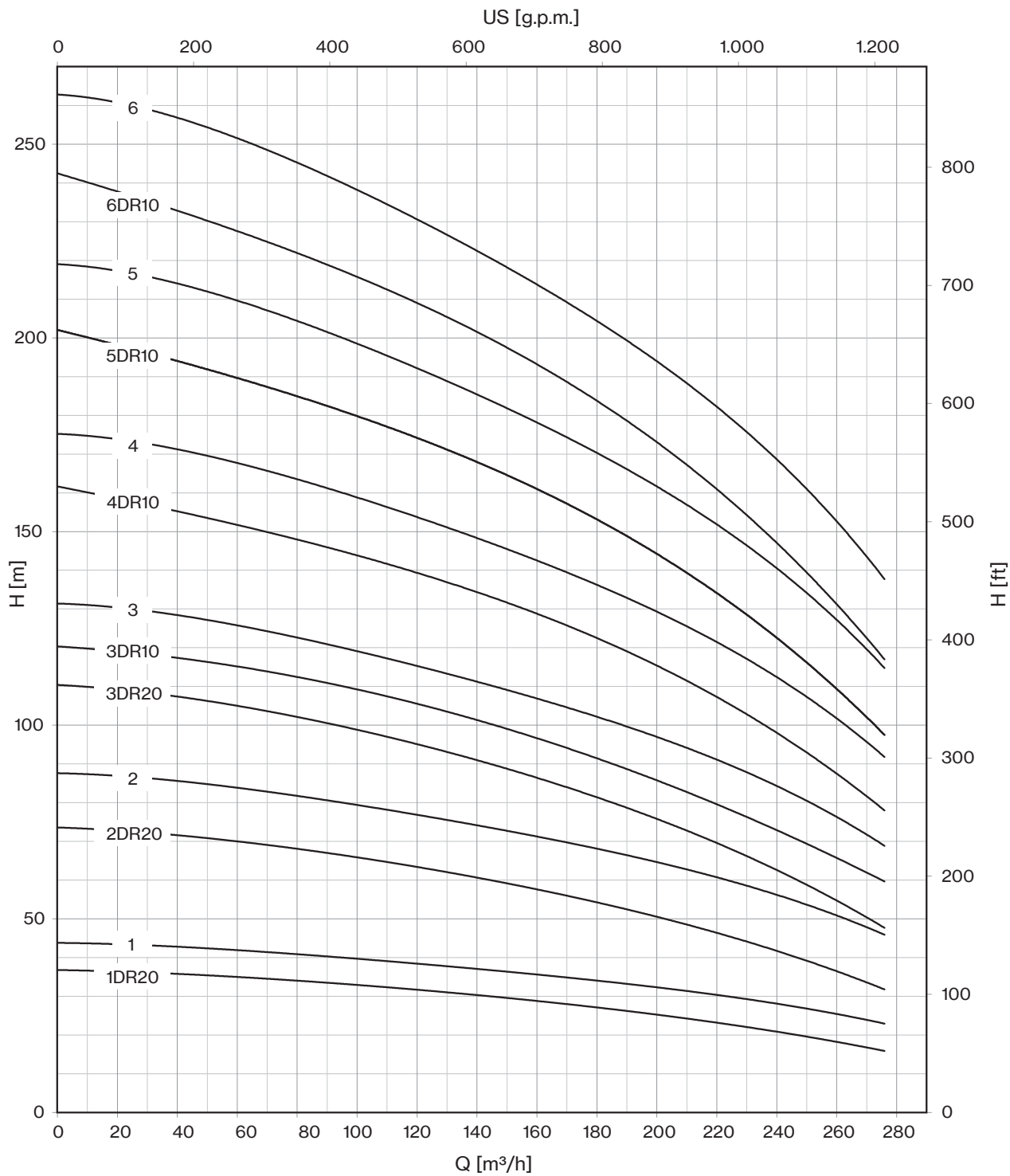

# 10LM 230

50 Hz - 2900 rpm				Q									
TYPE	SUITABLE MOTOR 3- 400V		I/min	0	800	2200	2600	3000	3400	3800	4200	4600	
	P2		CURRENT	I/sec	0	13,3	36,7	43,3	50,0	56,7	63,3	70,0	76,7
	HP	kW	A	m³/h	0	48	132	156	180	204	228	252	276
10LM 230/07DR10D	200	150	277,2	H (m)	283	270	238	228	214	200	182	160	137
10LM 230/07D	225	165	313,3		307	298	263	252	238	224	207	185	161
10LM 230/08DR10D	225	165	313,3		323	308	272	261	245	229	208	182	157
10LM 230/08D	250	185	342,2		350	340	301	288	272	256	237	211	184
10LM 230/09D	300	220	430,0		394	383	338	324	306	288	266	238	207
10LM 230/10D	340	250	481,0		438	425	376	360	340	320	296	264	230
10LM 230/11D	340	250	481,0		482	468	413	396	374	352	326	291	253

Max Eff. % DR20 =	78,4
Max Eff. % DR10 =	79,5
Max Eff. %	79,2
Max kW / St. DR20 =	17,5
Max kW / St. DR10 =	19,5
Max kW / St.	22,8

NPSH (m)	Q=25%	Q=50%	Q=75%	Q=100%
	3,4	5	7,8	11,8

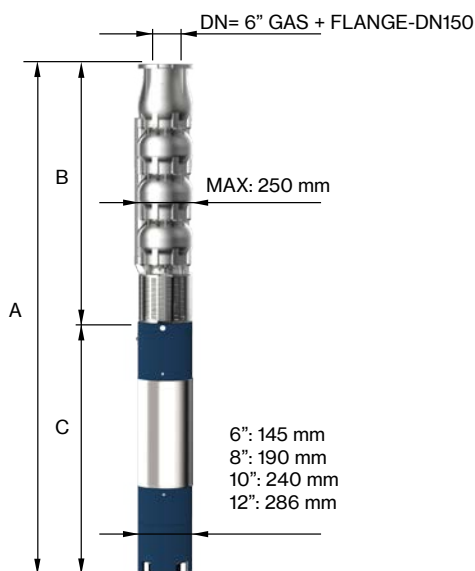

TYPE	MOTOR BRACKET	DIMENSIONS (mm)			WEIGHT (kg)	
		A	B	C	MOTOR	PUMP
10LM 230/07DR10D	10"	3439	1705	1734	415	134
10LM 230/07D		3559	1705	1854	444	134
10LM 230/08DR10D		3739	1885	1854	444	149
10LM 230/08D		3869	1885	1984	480	149
10LM 230/09D-12	12"	4175	2065	2110	700	165
10LM 230/10D-12		4355	2245	2110	700	180
10LM 230/11D-12		4705	2425	2280	775	196

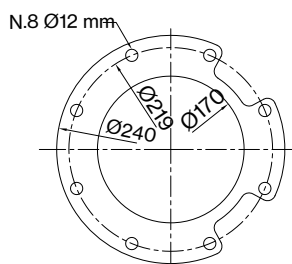

FOR COMMERCIAL TUBE  
EXTERNAL DIAMETER: 168,3 mm

"DR": reduced-diameter impellers  
"D" Pump shaft in Duplex EN 1.4462



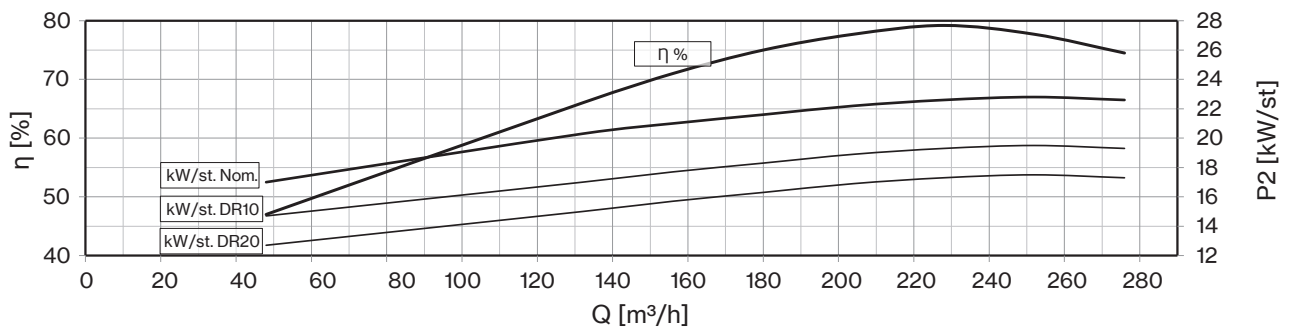
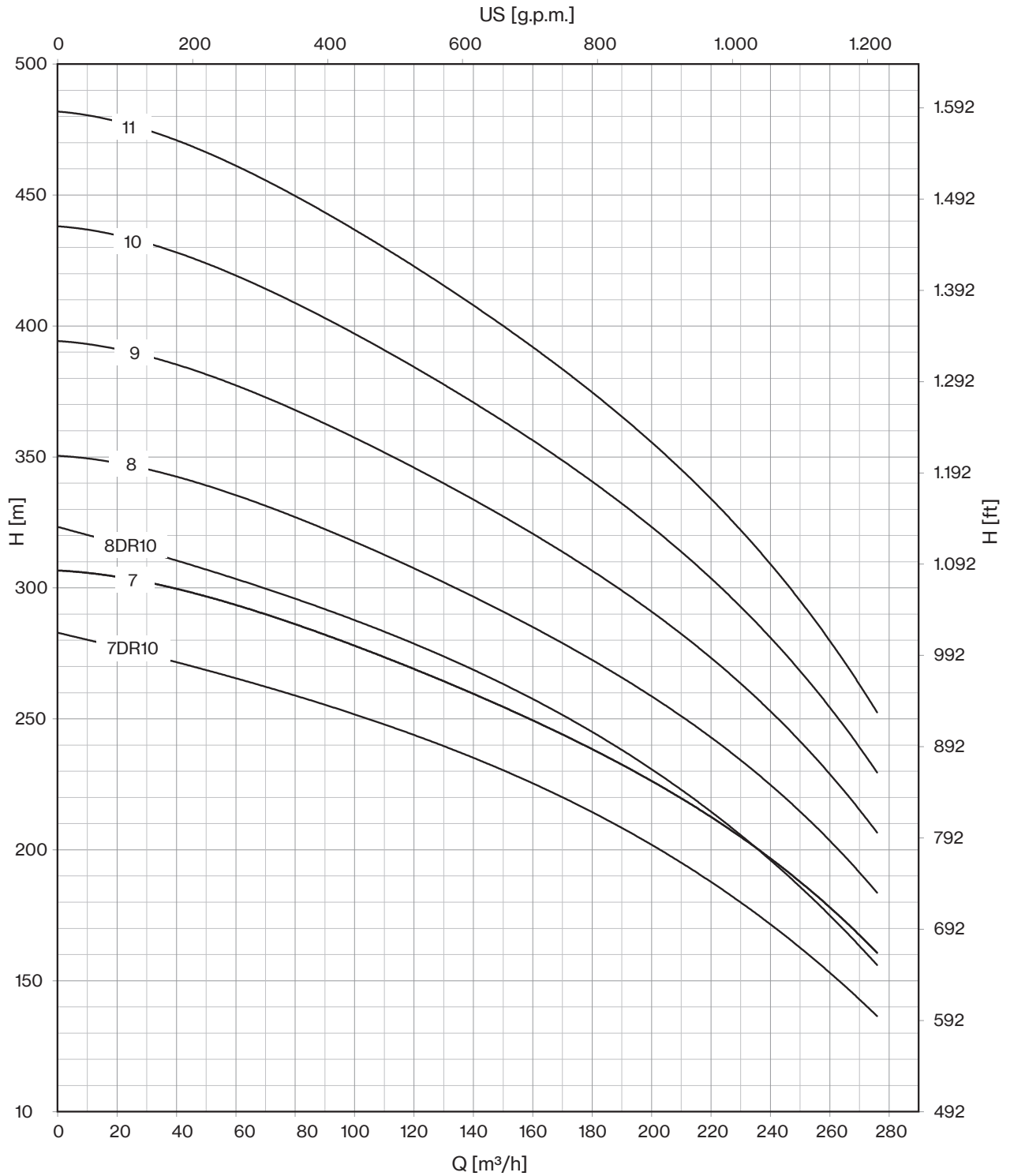

# 10LM 250

50 Hz - 2900 rpm				Q									
TYPE	SUITABLE MOTOR 3- 400V		I/min	0	1000	3200	3600	4000	4400	4800	5000	5200	
	P2		CURRENT	I/sec	0	16,7	53,3	60,0	66,7	73,3	80,0	83,3	86,7
	HP	kW	A	m³/h	0	60	192	216	240	264	288	300	312
10LM 250/01DR20	25	18,5	38,3	H (m)	31	31	27	25	23	21	18	17	14
10LM 250/01	40	30	61,1		44	42	34	32	30	28	26	25	24
10LM 250/02DR20	50	37	75,8		63	62	54	50	46	42	36	33	27
10LM 250/02	75	55	106,2		88	84	67	64	59	56	52	50	48
10LM 250/03DR10	100	75	143,2		107	107	93	86	80	73	65	59	53
10LM 250/03	125	92	175,1		132	126	101	96	89	83	78	75	72
10LM 250/04DR10	125	92	175,1		143	142	124	115	107	97	87	79	70
10LM 250/04D	150	110	211,0		176	168	134	128	118	111	104	100	96
10LM 250/05DR10D	175	130	245,3		179	178	155	144	134	121	109	99	88
10LM 250/05D	200	150	277,2		220	210	168	160	148	139	130	125	120
10LM 250/06D	225	165	313,3		264	252	202	192	178	167	156	150	144

Max Eff. % DR20 =	79
Max Eff. % DR10 =	79,5
Max Eff. %	79,3
Max kW / St. DR20 =	18
Max kW / St. DR10 =	22,5
Max kW / St.	27,4

NPSH (m)	Q=25%	Q=50%	Q=75%	Q=100%
	3,4	5	7,8	11,8

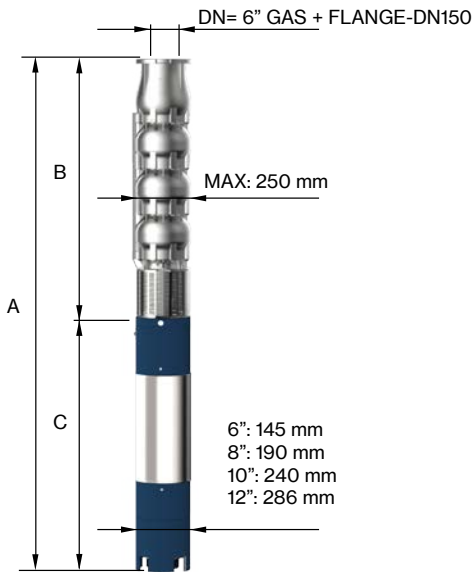

TYPE	MOTOR BRACKET	DIMENSIONS (mm)			WEIGHT (kg)	
		A	B	C	MOTOR	PUMP
10LM 250/01DR20-6	6" NEMA	1616	625	991	83	41
10LM 250/01-6		1876	625	1251	108	41
10LM 250/02DR20-6		2146	805	1341	118	57
10LM 250/02-8	8" NEMA	2038	805	1233	200	57
10LM 250/03DR10-8		2368	985	1383	230	72
10LM 250/03-8		2568	985	1583	270	72
10LM 250/04DR10-8		2748	1165	1583	270	88
10LM 250/04D-8	10"	2898	1165	1733	300	88
10LM 250/05DR10D		2979	1345	1634	385	103
10LM 250/05D		2979	1345	1634	385	103
10LM 250/06D		3379	1525	1854	444	119

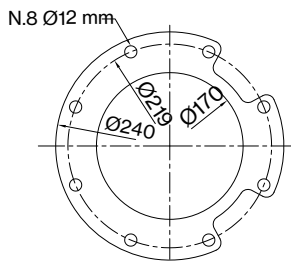

FOR COMMERCIAL TUBE  
EXTERNAL DIAMETER: 168,3 mm

"DR" : reduced-diameter impellers  
"D" Pump shaft in Duplex EN 1.4462



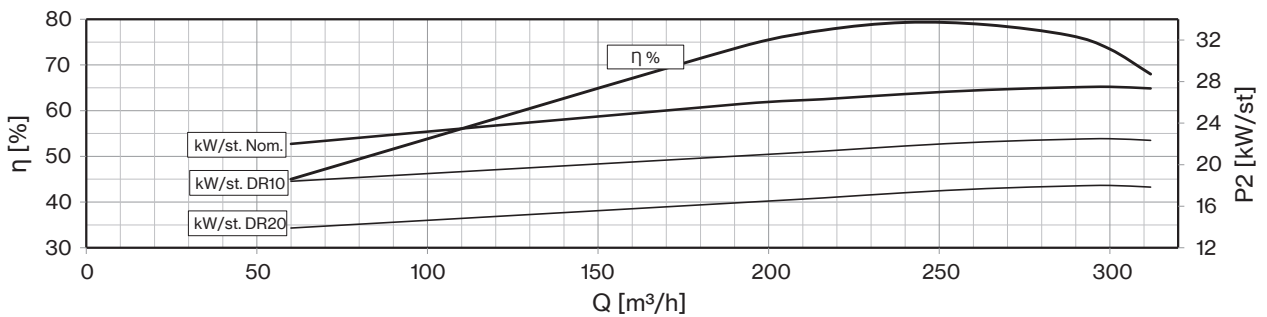
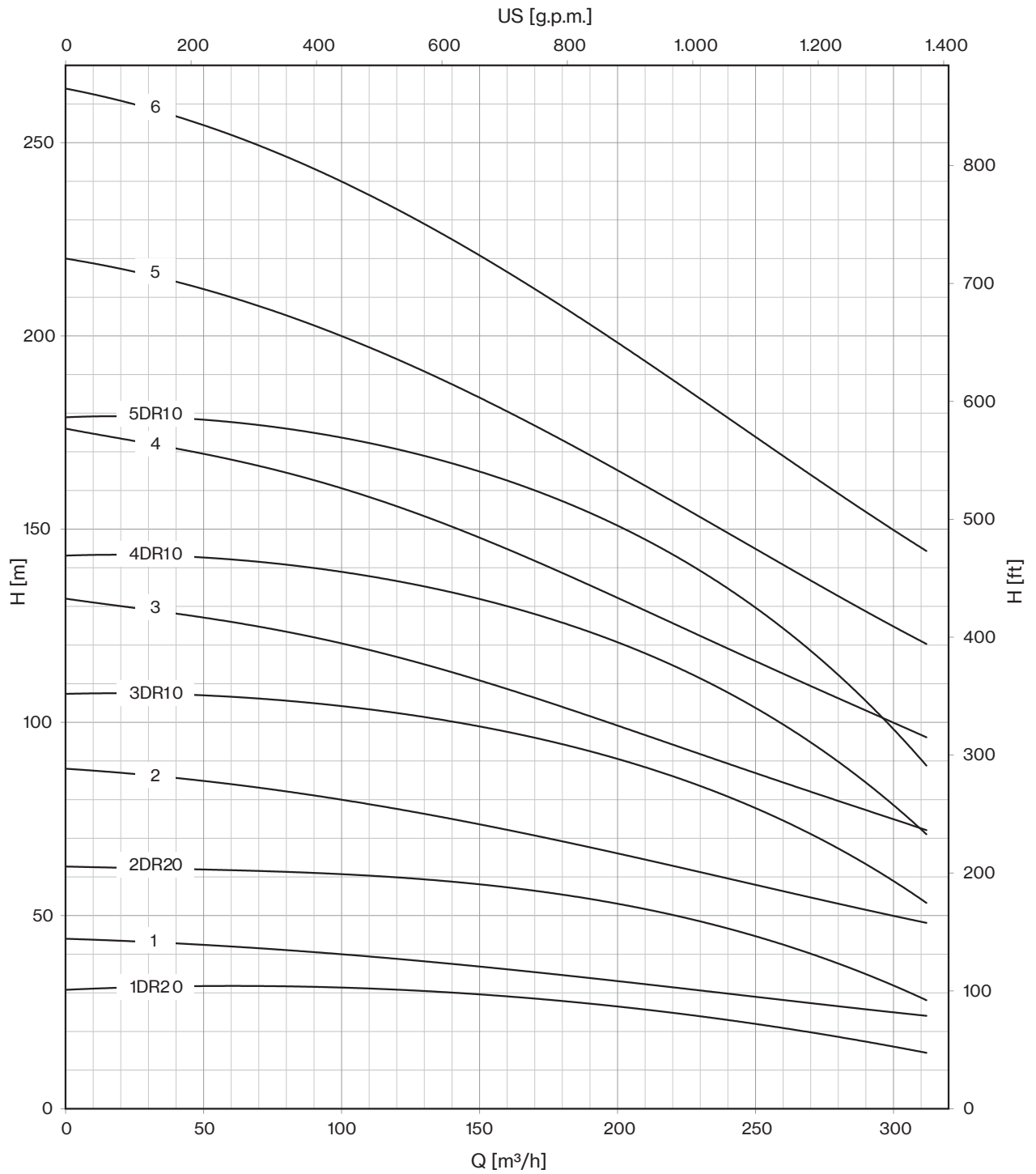

# 10LM 250

50 Hz - 2900 rpm				Q									
TYPE	SUITABLE MOTOR 3- 400V		I/min	0	1000	3200	3600	4000	4400	4800	5000	5200	
	P2		CURRENT	I/sec	0	16,7	53,3	60,0	66,7	73,3	80,0	83,3	86,7
	HP	kW	A	m³/h	0	60	192	216	240	264	288	300	312
10LM 250/07DR10D	225	165	313,3	H (m)	251	249	217	202	188	169	153	139	123
10LM 250/07D	300	220	430,0		308	294	235	224	207	195	182	175	168
10LM 250/08D	300	220	430,0		352	336	269	256	237	222	208	200	192
10LM 250/09D	340	250	481,0		396	378	302	288	266	250	234	225	216
10LM 250/10D	400	300	551,0		440	420	336	320	296	278	260	250	240
10LM 250/11D	450	330	620,0		484	462	370	352	326	306	286	275	264
10LM 250/12D	450	330	620,0		528	504	403	384	355	334	312	300	288

Max Eff. % DR20 =	79
Max Eff. % DR10 =	79,5
Max Eff. %	79,3
Max kW / St. DR20 =	18
Max kW / St. DR10 =	22,5
Max kW / St.	27,4

NPSH (m)	Q=25%	Q=50%	Q=75%	Q=100%
	3,4	5	7,8	11,8

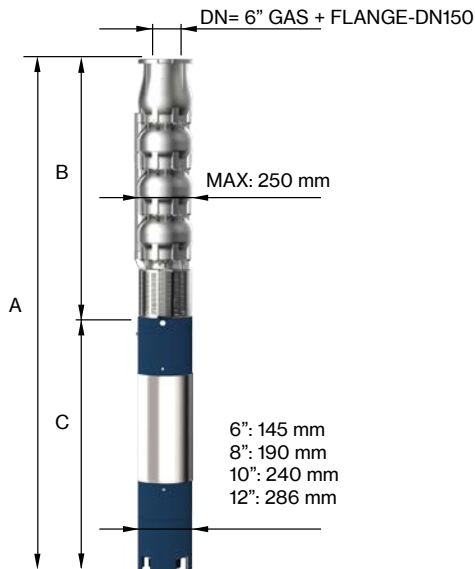

TYPE	MOTOR BRACKET	DIMENSIONS (mm)			WEIGHT (kg)	
		A	B	C	MOTOR	PUMP
10LM 250/07DR10D	10"	3559	1705	1854	444	134
10LM 250/07D-12	12"	3815	1705	2110	700	134
10LM 250/08D-12		3995	1885	2110	700	150
10LM 250/09D-12	14"	4345	2065	2280	775	165
10LM 250/10D-14		4525	2245	2280	775	181
10LM 250/11D-14		4705	2425	2280	775	196
10LM 250/12D-14		4765	2605	2160	906	212

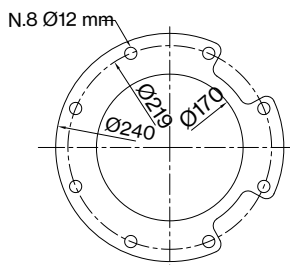

FOR COMMERCIAL TUBE  
EXTERNAL DIAMETER: 168,3 mm

"DR": reduced-diameter impellers  
"D" Pump shaft in Duplex EN 1.4462



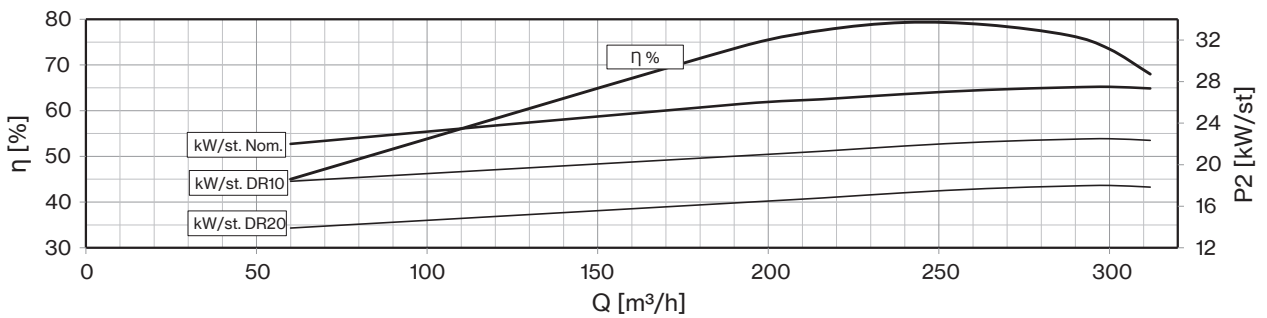
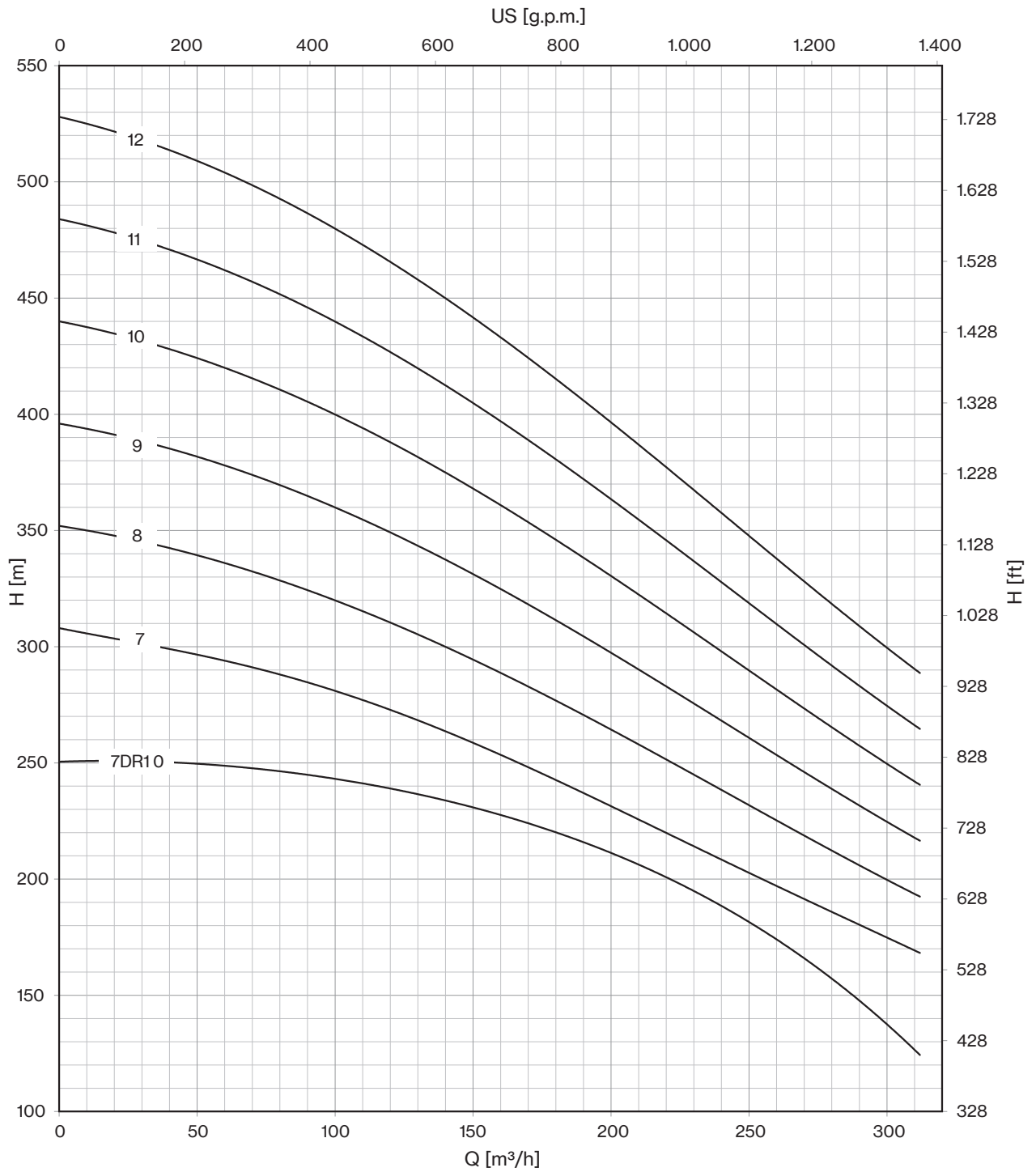

# 10LM 275

50 Hz - 2900 rpm				Q									
TYPE	SUITABLE MOTOR 3- 400V		I/min	0	1000	3400	3800	4200	4600	5000	5400	5800	
	P2		CURRENT	I/sec	0	16,7	56,7	63,3	70,0	76,7	83,3	90,0	96,7
	HP	kW	A	m³/h	0	60	204	228	252	276	300	324	348
10LM 275/01DR20	35	26	52,9	H (m)	36	36	28	26	25	23	21	19	16
10LM 275/01	50	37	75,8		45	44	37	35	34	32	30	28	25
10LM 275/02DR20	75	55	106,2		72	71	56	52	50	46	42	39	32
10LM 275/02	90	66	126,0		90	87	73	70	67	63	60	56	50
10LM 275/03DR10	125	92	175,1		122	121	97	92	88	82	77	72	62
10LM 275/03D	150	110	211,0		135	131	110	105	101	95	90	85	75
10LM 275/04DR10D	175	130	245,3		163	161	130	123	118	110	103	96	83
10LM 275/04D	200	150	277,2		180	175	146	140	134	126	120	113	100
10LM 275/05DR10D	200	150	277,2		204	202	162	154	147	137	129	120	104
10LM 275/05D	225	165	313,3		225	219	183	175	168	158	150	141	125
10LM 275/06DR10D	250	185	342,2		245	242	194	185	176	164	155	144	125
10LM 275/06D	300	220	430,0		270	262	220	210	202	190	180	169	150

Max Eff. % DR20 =	76,1
Max Eff. % DR10 =	77,2
Max Eff. %	76,5
Max kW / St. DR20 =	25
Max kW / St. DR10 =	29
Max kW / St.	33

NPSH (m)	Q=25%	Q=50%	Q=75%	Q=100%
	3,4	5	7,8	11,8

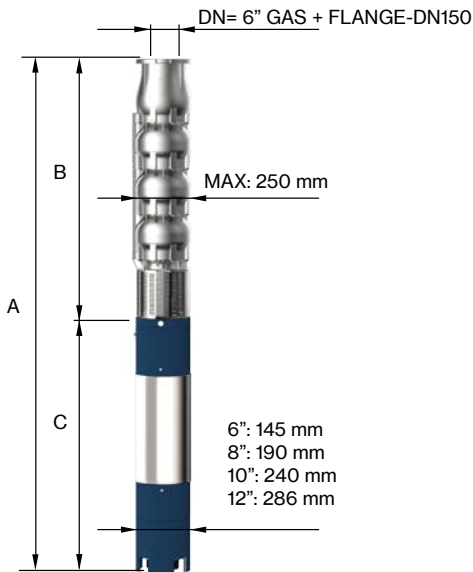

TYPE	MOTOR BRACKET	DIMENSIONS (mm)			WEIGHT (kg)	
		A	B	C	MOTOR	PUMP
10LM 275/01DR20-6	6" NEMA	1806	625	1181	100	41
10LM 275/01-6		1966	625	1341	118	41
10LM 275/02DR20-8	8" NEMA	2038	805	1233	200	56
10LM 275/02-8		2107	805	1302	214	56
10LM 275/03DR10-8		2568	985	1583	270	72
10LM 275/03D-8	10"	2718	985	1733	300	72
10LM 275/04DR10D		2799	1165	1634	385	87
10LM 275/04D		2899	1165	1734	415	87
10LM 275/05DR10D		3079	1345	1734	415	103
10LM 275/05D		3199	1345	1854	444	103
10LM 275/06DR10D		3509	1525	1984	480	118
10LM 275/06D		3635	1525	2110	700	118

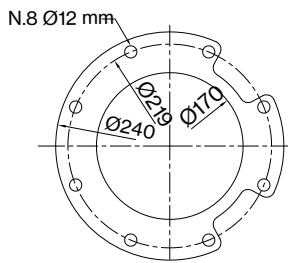

FOR COMMERCIAL TUBE  
EXTERNAL DIAMETER: 168,3 mm

"DR" : reduced-diameter impellers  
"D" Pump shaft in Duplex EN 1.4462



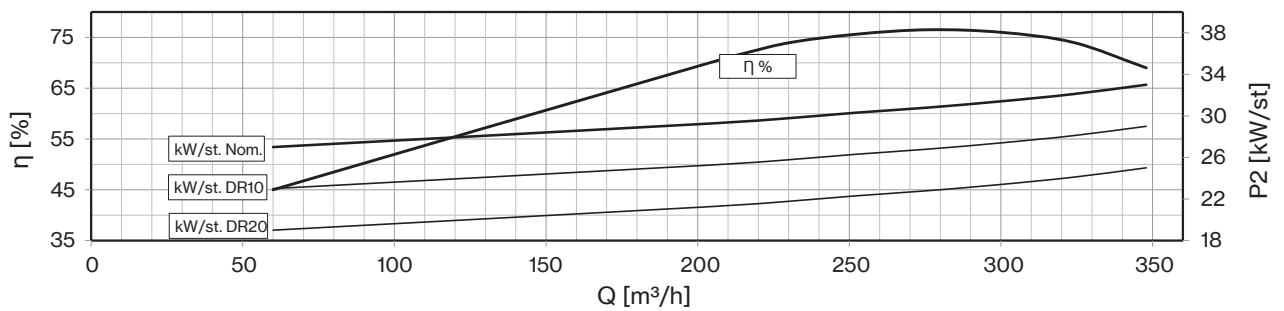
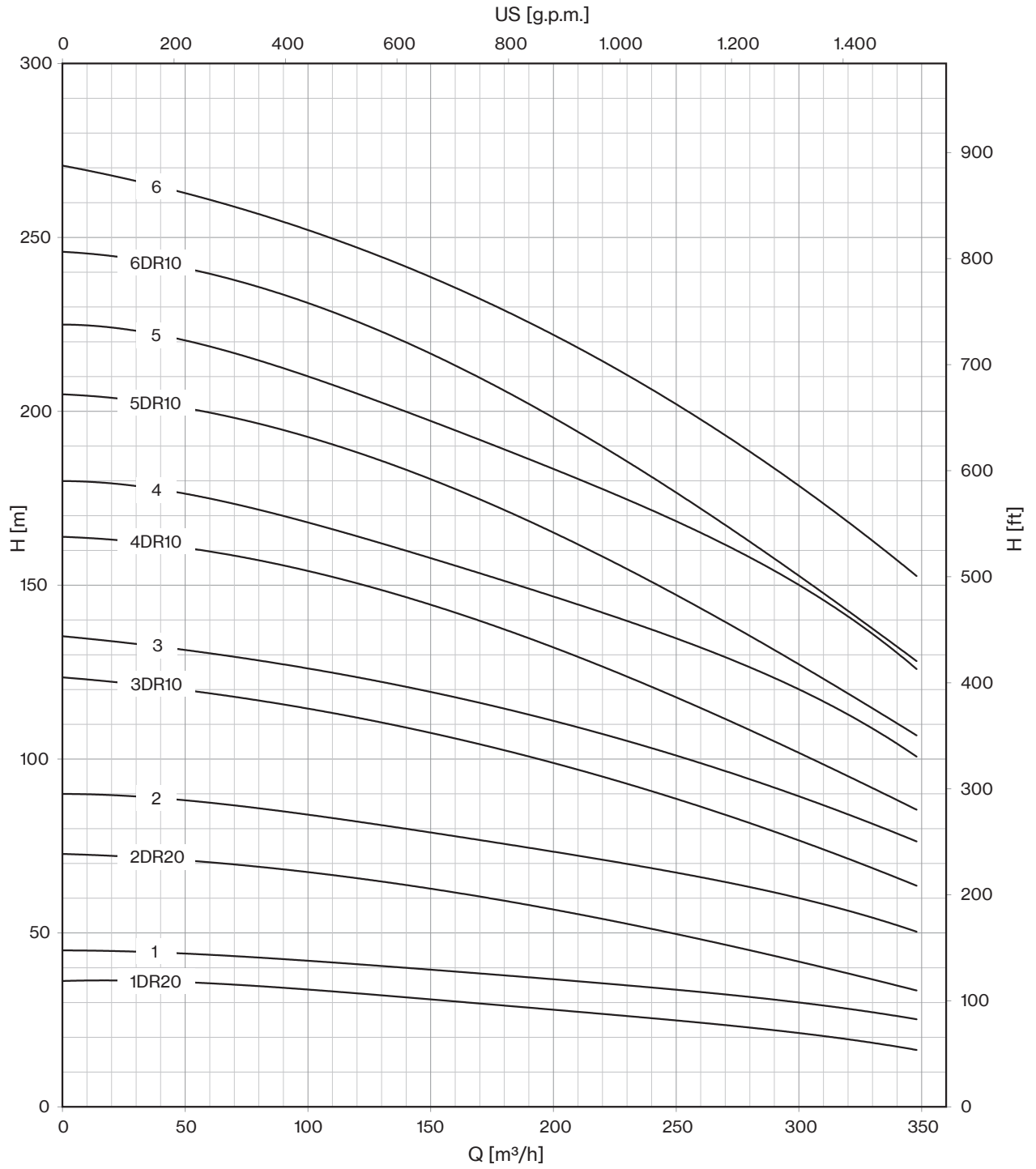

# 10LM 275

50 Hz - 2900 rpm				Q									
TYPE	SUITABLE MOTOR 3- 400V		I/min	0	1000	3400	3800	4200	4600	5000	5400	5800	
	P2		CURRENT	I/sec	0	16,7	56,7	63,3	70,0	76,7	83,3	90,0	96,7
	HP	kW	A	m³/h	0	60	204	228	252	276	300	324	348
10LM 275/07DR10D	300	220	430,0	H (m)	286	282	227	216	206	192	181	168	146
10LM 275/07D	340	250	481,0		315	306	256	245	235	221	210	197	175
10LM 275/08D	400	300	551,0		360	350	293	280	269	253	240	226	200
10LM 275/09D	400	300	551,0		405	393	329	315	302	284	270	254	225
10LM 275/10D	450	330	620,0		450	437	366	350	336	316	300	282	250
10LM 275/11D	500	370	693,0		495	481	403	385	370	348	330	310	275
10LM 275/12D	550	400	798,0		540	524	439	420	403	379	360	338	300

Max Eff. % DR20 =	76,1
Max Eff. % DR10 =	77,2
Max Eff. %	76,5
Max kW / St. DR20 =	25
Max kW / St. DR10 =	29
Max kW / St.	33

NPSH (m)	Q=25%	Q=50%	Q=75%	Q=100%
	3,4	5	7,8	11,8

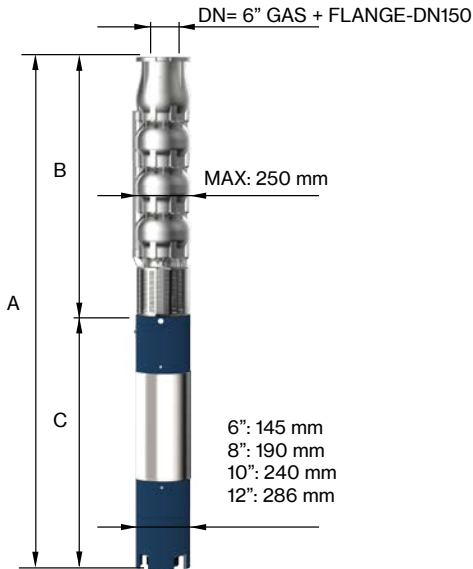

TYPE	MOTOR BRACKET	DIMENSIONS (mm)			WEIGHT (kg)	
		A	B	C	MOTOR	PUMP
10LM 275/07DR10D-12	12"	3815	1705	2110	700	134
10LM 275/07D-12		3985	1705	2280	775	134
10LM 275/08D-14		4165	1885	2280	775	149
10LM 275/09D-14	14"	4345	2065	2280	775	165
10LM 275/10D-14		4405	2245	2160	906	180
10LM 275/11D-14		4585	2425	2160	906	196
10LM 275/12D-14		4925	2605	2320	1010	211

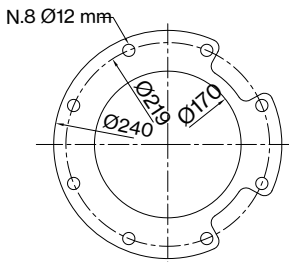

FOR COMMERCIAL TUBE  
EXTERNAL DIAMETER: 168,3 mm

"DR" : reduced-diameter impellers  
"D" Pump shaft in Duplex EN 1.4462



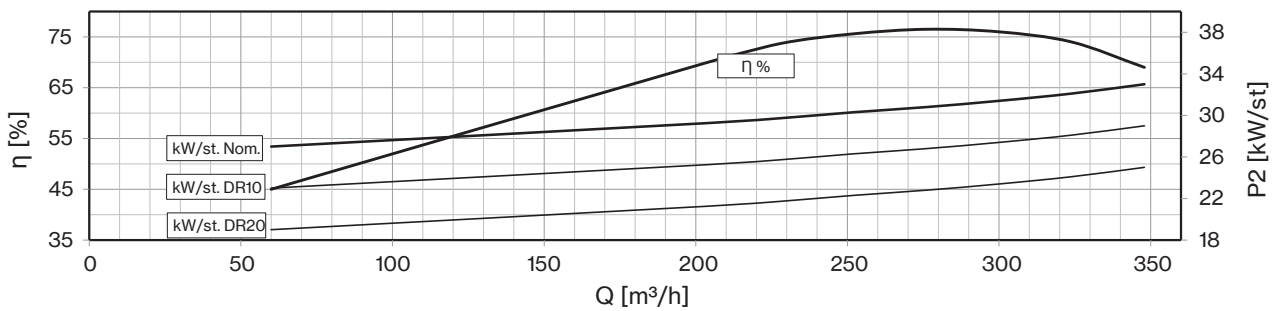
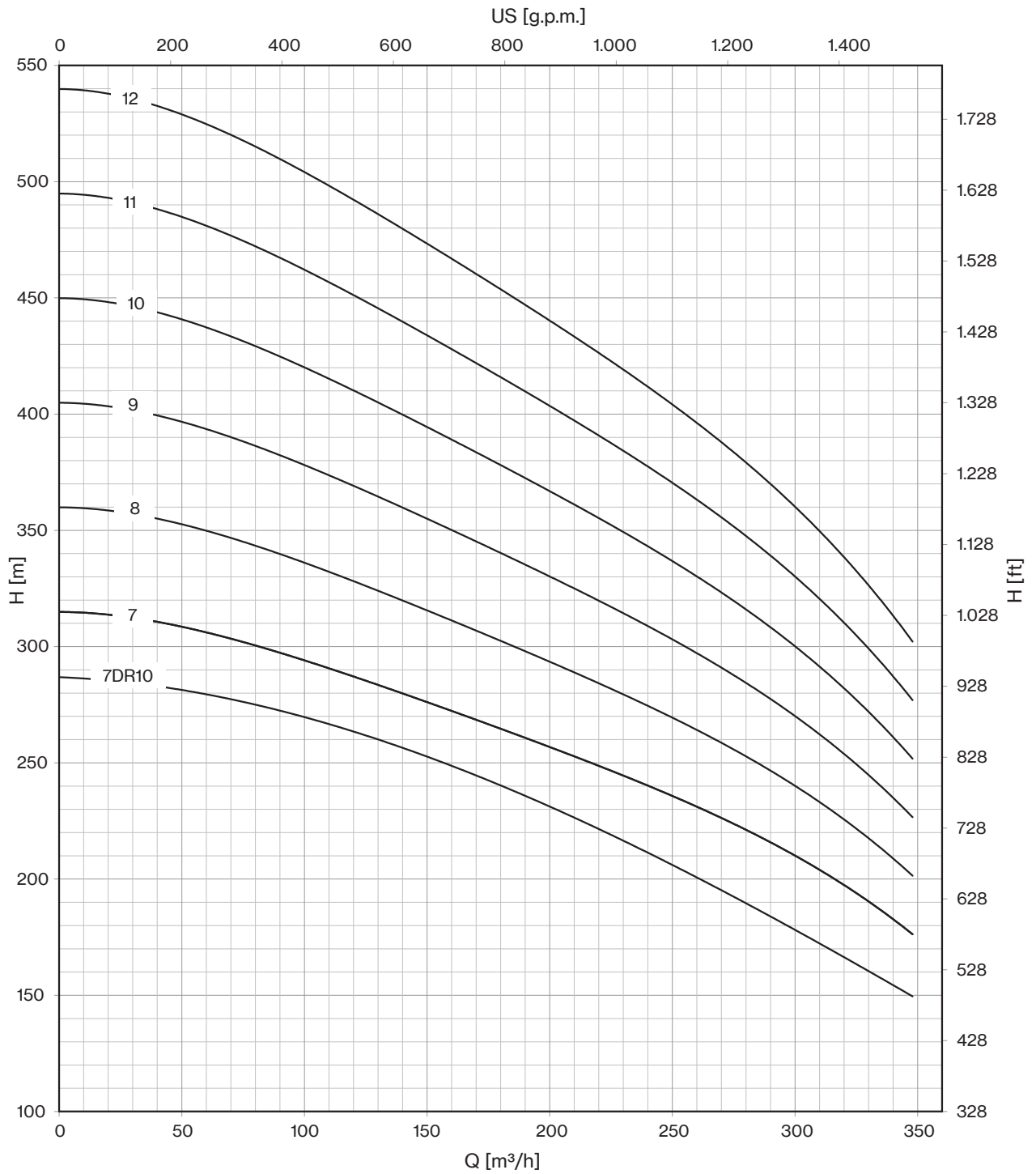

# 10LM-12LM

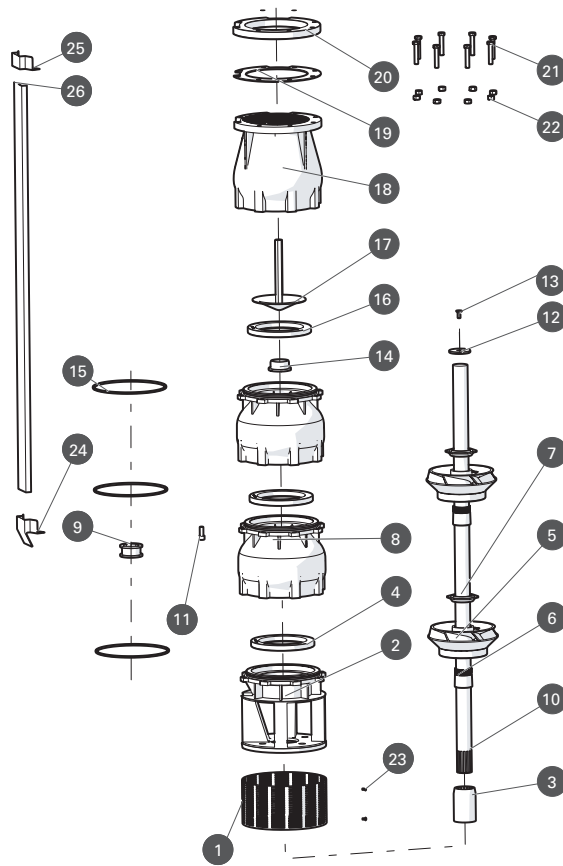

N. CODE	DESCRIPTION	LMS EXECUTION	LMX EXECUTION	LMD EXECUTION	(*) Q.TY
1	<b>SUCTION STRAINER</b>	AISI 304	AISI 316	Duplex EN 1.4462	-
2	<b>MOTOR BRACKET</b>	AISI 304	AISI 316	Duplex EN 1.4462	-
3	<b>COUPLING</b>	AISI 304	AISI 316	Duplex EN 1.4462	1
4	<b>WEAR RING</b>	NBR	NBR	NBR	N° of Stages
5	<b>IMPELLER</b>	AISI 304	AISI 316	Duplex EN 1.4462	-
6	<b>CONE</b>	AISI 304	AISI 316	Duplex EN 1.4462	N° of Stages
7	<b>HEXAGONAL RING</b>	AISI 304	AISI 316	Duplex EN 1.4462	N° of Stages
8	<b>DIFFUSER</b>	AISI 304	AISI 316	Duplex EN 1.4462	-
9	<b>BEARING BUSH</b>	NBR	NBR	NBR	N° of Stages
10	<b>PUMP SHAFT</b>	AISI 304	AISI 316	Duplex EN 1.4462	1
11	<b>N.8 SCREW FOR DIFFUSEUR</b>	AISI 304	AISI 316	Duplex EN 1.4462	-
12	<b>RING</b>	AISI 304	AISI 316	Duplex EN 1.4462	1
13	<b>SCREW FOR DISK</b>	AISI 304	AISI 316	Duplex EN 1.4462	1
14	<b>COUNTERTHRUST</b>	PTFE + 25% CARBON	PTFE + 25% CARBON	PTFE + 25% CARBON	1
15	<b>O-RING</b>	NBR	NBR	NBR	N° of Stages
16	<b>GASKET VALVE</b>	NBR	NBR	NBR	1
17	<b>CAP VALVE</b>	AISI 304	AISI 316	Duplex EN 1.4462	-
18	<b>BODY VALVE</b>	AISI 304	AISI 316	Duplex EN 1.4462	-
19	<b>SEAL COUNTERFLANGE</b>	NBR	NBR	NBR	1
20	<b>COUNTERFLANGE</b>	AISI 304	AISI 316	Duplex EN 1.4462	-
21	<b>N.8 SCREW FOR COUNTERFLANGE</b>	AISI 304	AISI 316	Duplex EN 1.4462	-
22	<b>N.8 NUT FOR COUNTERFLANGE</b>	AISI 304	AISI 316	Duplex EN 1.4462	-
23	<b>N.2 SCREW FOR SUCTION STRAINER</b>	AISI 304	AISI 316	Duplex EN 1.4462	-
24	<b>LOWER CLAMP</b>	AISI 304	AISI 316	Duplex EN 1.4462	-
25	<b>UPPER CLAMP</b>	AISI 304	AISI 316	Duplex EN 1.4462	-
26	<b>COVER CABLE</b>	AISI 304	AISI 316	Duplex EN 1.4462	-

\* Recommended spare parts quantity

