

# 10-12LM & E14 lines

## Deepwell Borehole

Submersible Multistage Centrifugal Pumps for 10", 12", and 14" Wells. These pumps are equipped with a check valve integrated into the delivery outlet. The pump motor bracket and coupling are designed in accordance with NEMA standards, ensuring reliability and compatibility. Common applications include civil and agricultural uses. All components are manufactured from stainless steel using lost wax microfusion technology. The standard material is AISI 304 stainless steel, with the following materials available upon request: AISI 316 stainless steel, Duplex steel (EN 1.4462), and AISI 904L stainless steel. The bushing bearings and wear rings are made from sand abrasion-resistant rubber, while the reverse-thrust ring is constructed from PTFE/Graphite for enhanced durability and performance.

### General operating data:

- Capacity up to 860 m<sup>3</sup>/h
- Pressure up to 540 m
- Hydraulic efficiency 10", up to 79,3%
- Hydraulic efficiency 12", up to 82,5%
- Hydraulic efficiency 14", up to 85,7%
- Powers up to 400 kW
- Rotation speed 2.900 rpm
- Maximum depth: 350 m
- Maximum quantity of sand: 100 gr/m<sup>3</sup>
- Drinking water compatibility according to DM174 MEI ≥ 0,4 (EU directive No.547/2012)
- Performance tolerance: ISO9906-3B.

### Construction features

<b>Suction and delivery outlet and NRV valve</b>	stainless steel AISI 304 (LMS) stainless steel AISI 316 (LMX - EX) Duplex EN 1.4462 (LMD - ED) Cast iron (E)
<b>Impellers and diffusers</b>	stainless steel AISI 304 (LMS) stainless steel AISI 316 (LMX - EX) Duplex EN 1.4462 (LMD - ED) Cast iron (E)
<b>Upper bushings</b>	NBR rubber
<b>Shaft pump side</b>	stainless steel AISI 304 (LMS) stainless steel AISI 316 (LMX) Duplex EN 1.4462 (LMD) stainless steel AISI 431 (E - EX - ED)
<b>Quantity of sand in the water</b>	max 100 g/m <sup>3</sup>

### Motor

<b>Asynchronous 2 pole</b>	rewindable water cooled
<b>Insulation class</b>	Y (max 30 °C) - PPC winding type F (max 50 °C) - PE2+PA or LPE winding type
<b>Protection degree</b>	IP68
<b>Liquid temperature</b>	max 30 °C (max 50 °C on request)
<b>Depth of immersion</b>	max 350 m



10LM line



12LM line



E14

# 12LM 360

50 Hz - 2900 rpm				Q									
TYPE	SUITABLE MOTOR 3- 400V		l/min	0	1500	4000	4500	5000	5500	6000	6500	7000	
	P2		CURRENT	l/sec	0	25,0	66,7	75,0	83,3	91,7	100,0	108,3	116,7
	HP	kW	A	m³/h	0	90	240	270	300	330	360	390	420
12LM 360/01DR35	50	37	75,8	H (m)	41	40	37	35	33	32	29		
12LM 360/01DR20	75	55	106,2		49	48	47	45	44	42	40	38	34
12LM 360/01	90	66	126,0		62	61	55	53	52	52	50	47	42
12LM 360/02DR35	100	75	143,2		82	80	73	70	66	63	57		
12LM 360/02DR20D	150	110	211,0		98	96	93	90	87	84	80	75	68
12LM 360/02D	175	130	245,3		124	122	109	106	104	103	100	93	84
12LM 360/03DR20D	200	150	277,2		147	144	140	135	131	126	120	113	102
12LM 360/03DR10D	250	185	342,2		165	162	152	149	144	140	132	126	120
12LM 360/03D	300	220	430,0		186	183	164	159	156	155	150	140	126
12LM 360/04DR20D	300	220	430,0		196	192	186	180	174	168	160	150	136
12LM 360/04DR10D	340	250	481,0		220	216	202	198	192	186	176	168	160
12LM 360/04D	400	300	551,0		248	244	218	212	208	206	200	186	168

Max Eff. % DR35 =	77,5
Max Eff. % DR20 =	80
Max Eff. % DR10 =	80,5
Max Eff. %	81
Max kW / St. DR35 =	36,80
Max kW / St. DR20 =	49,5
Max kW / St. DR10 =	55,2
Max kW / St.	64,2

NPSH (m)	Q=25%	Q=50%	Q=75%	Q=100%
	3,4	5	7,8	11,8

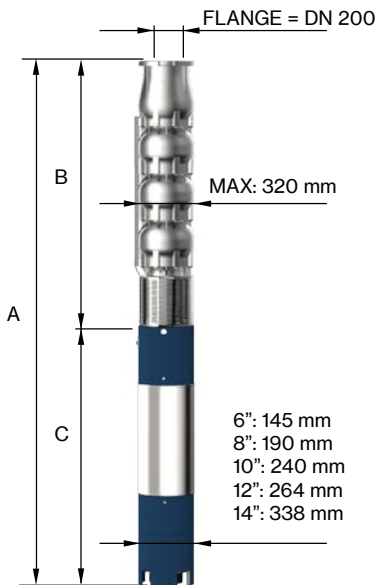

TYPE	MOTOR BRACKET	DIMENSIONS (mm)			WEIGHT (kg)	
		A	B	C	MOTOR	PUMP
12LM 360/01DR35-6	6" NEMA	2111	770	1341	118	79
12LM 360/01DR20-8	8" NEMA	2003	770	1233	200	79
12LM 360/01-8		2072	770	1302	214	79
12LM 360/02DR35-8		2383	1000	1383	230	104
12LM 360/02DR20D-8	10"	2733	1000	1733	300	104
12LM 360/02D-10		2634	1000	1634	385	104
12LM 360/03DR20D-10		2964	1230	1734	415	129
12LM 360/03DR10D-10	12"	3214	1230	1984	480	129
12LM 360/03D		3340	1230	2110	700	129
12LM 360/04DR20D		3570	1460	2110	700	154
12LM 360/04DR10D	14"	3740	1460	2280	775	154
12LM 360/04D-14		3740	1460	2280	775	154

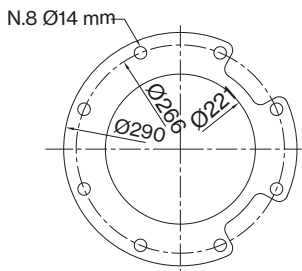

FOR COMMERCIAL TUBE  
EXTERNAL DIAMETER: 219,1 mm

"DR" : reduced-diameter impellers  
"D" Pump shaft in Duplex EN 1.4462



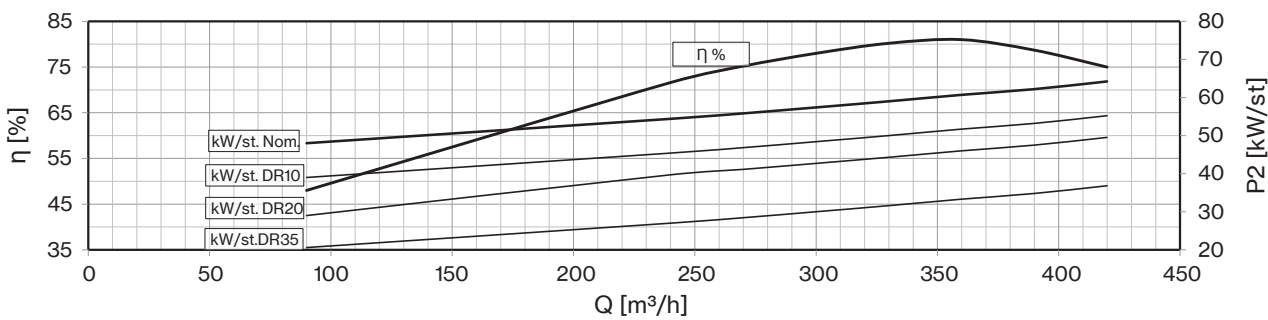
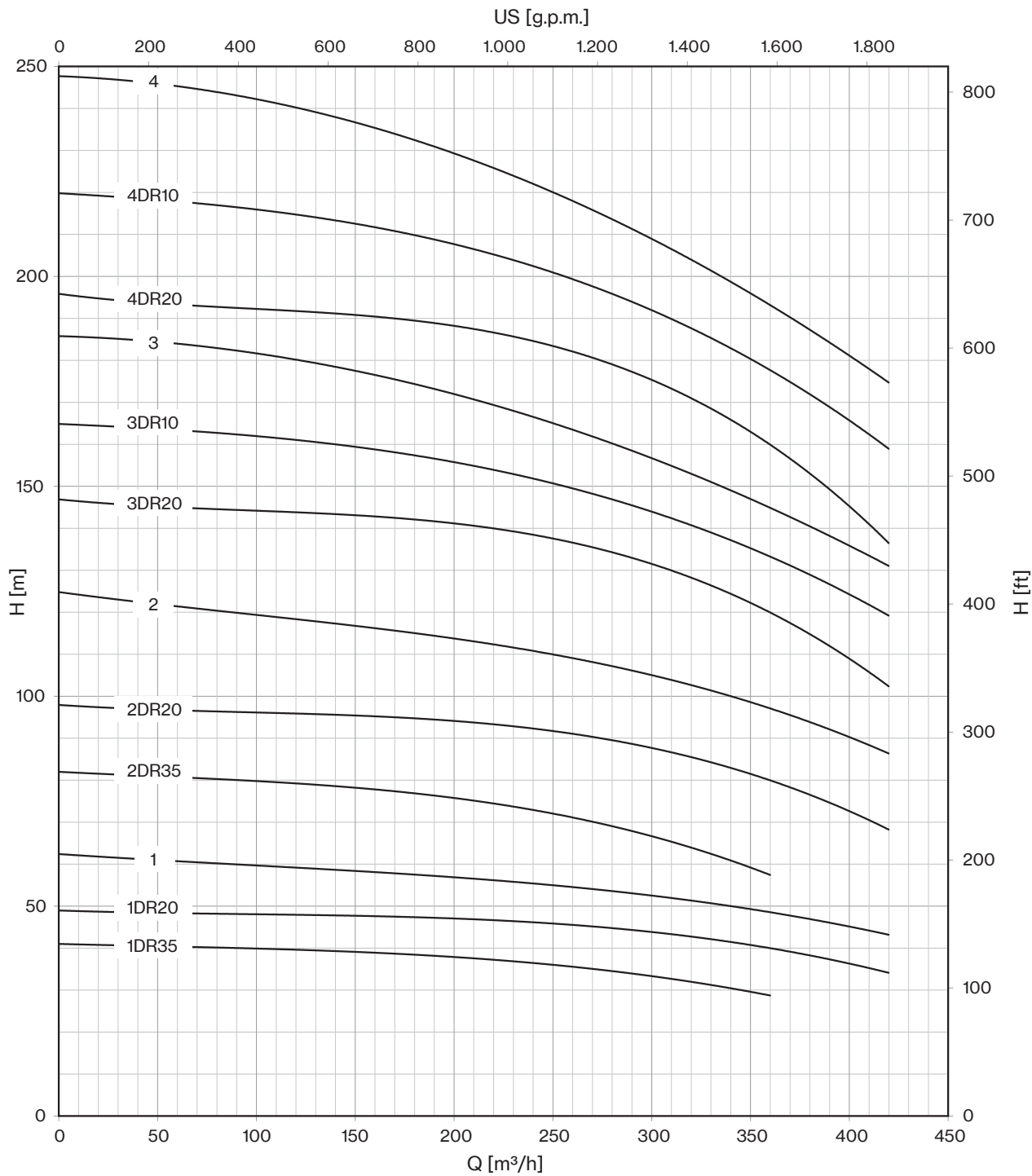

# 12LM 360

50 Hz - 2900 rpm				Q									
TYPE	SUITABLE MOTOR 3- 400V		I/min	0	1500	4000	4500	5000	5500	6000	6500	7000	
	P2		CURRENT	I/sec	0	25,0	66,7	75,0	83,3	91,7	100,0	108,3	116,7
	HP	kW	A	m³/h	0	90	240	270	300	330	360	390	420
12LM 360/05DR20D	340	250	481,0	H (m)	245	240	233	225	218	210	200	188	170
12LM 360/05DR10D	400	300	551,0		275	270	253	248	240	233	220	210	200
12LM 360/05D	450	330	620,0		310	305	273	265	260	258	250	233	210
12LM 360/06DR10D	500	370	693,0		330	324	304	298	288	280	264	252	240
12LM 360/06D	550	400	798,0		372	366	328	318	312	310	300	280	252
12LM 360/07DR10D	550	400	798,0		385	378	354	347	336	326	308	294	280

Max Eff. % DR35 =	77,5
Max Eff. % DR20 =	80
Max Eff. % DR10 =	80,5
Max Eff. %	81
Max kW / St. DR35 =	36,80
Max kW / St. DR20 =	49,5
Max kW / St. DR10 =	55,2
Max kW / St.	64,2

NPSH (m)	Q=25%	Q=50%	Q=75%	Q=100%
	3,4	5	7,8	11,8

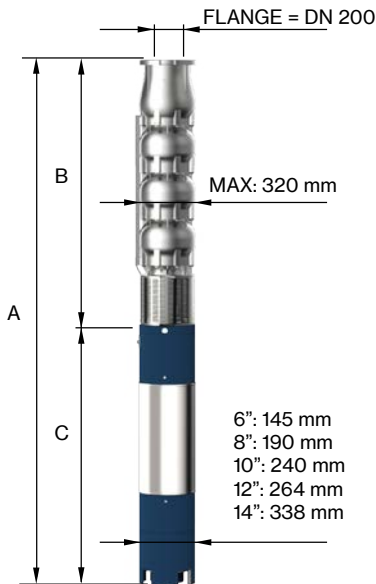

TYPE	MOTOR BRACKET	DIMENSIONS (mm)			WEIGHT (kg)	
		A	B	C	MOTOR	PUMP
12LM 360/05DR20D	12"	3970	1690	2280	775	179
12LM 360/05DR10D-14	14"	3970	1690	2280	775	179
12LM 360/05D-14		3850	1690	2160	906	179
12LM 360/06DR10D-14		4240	1920	2320	1010	204
12LM 360/06D-14		4380	1920	2460	1105	204
12LM 360/07DR10D-14		4610	2150	2460	1105	229

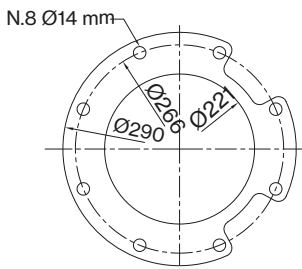

FOR COMMERCIAL TUBE  
EXTERNAL DIAMETER: 219,1 mm

"DR": reduced-diameter impellers  
"D" Pump shaft in Duplex EN 1.4462



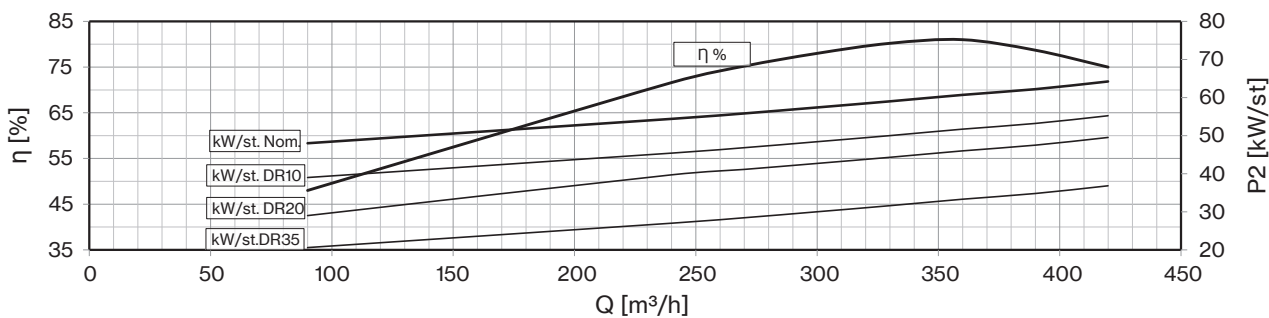
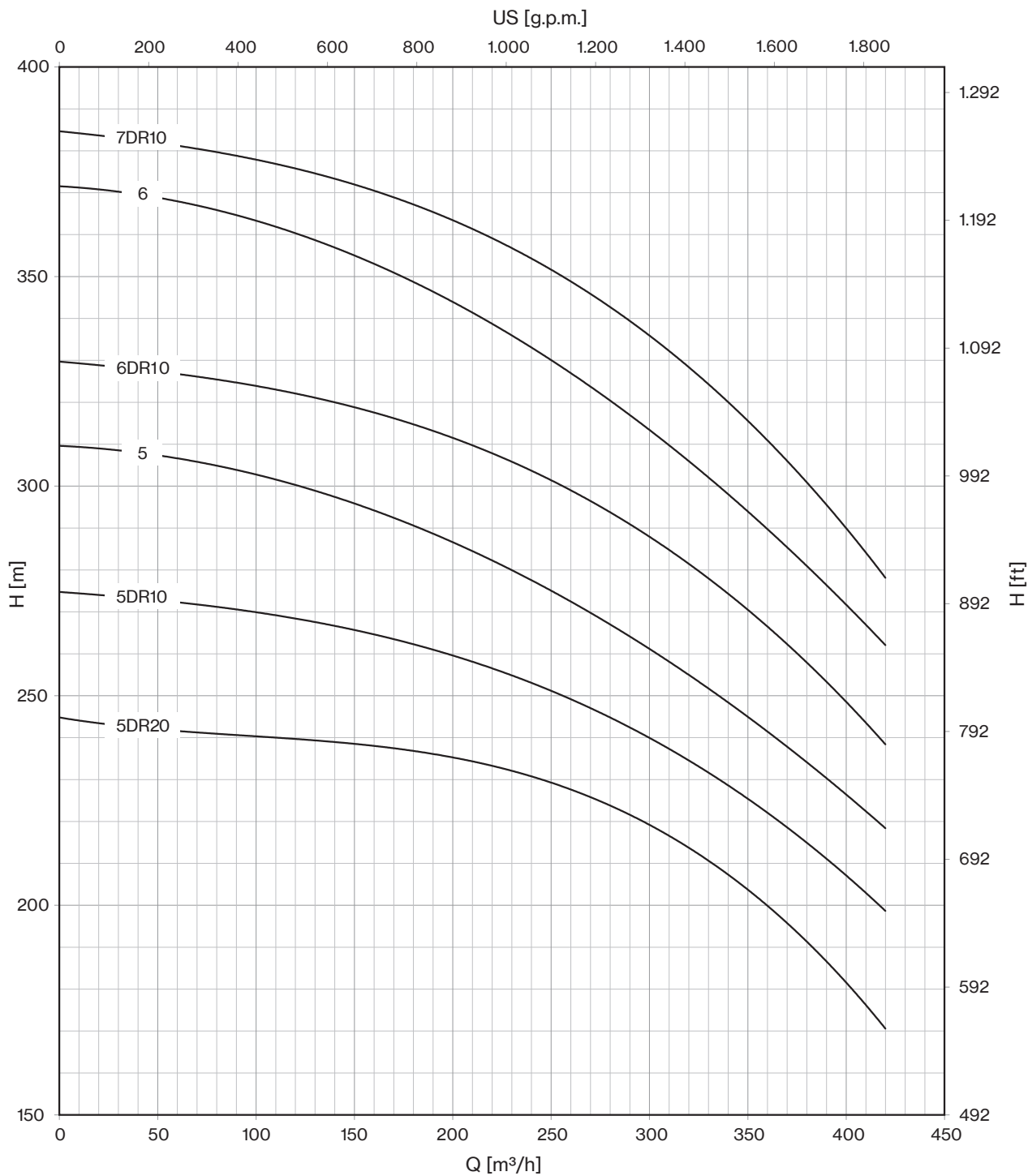

# 12LM 400

50 Hz - 2900 rpm				Q									
TYPE	SUITABLE MOTOR 3- 400V		I/min	0	2000	6000	6500	7000	7500	8000	8500	9000	
	P2		CURRENT	I/sec	0	33,3	100,0	108,3	116,7	125,0	133,3	141,7	150,0
	HP	kW	A	m³/h	0	120	360	390	420	450	480	510	540
12LM 400/01DR30	50	37	75,8	H (m)	43	42	32	30	27	24			
12LM 400/01DR20	75	55	106,2		47	45	37	35	33	30	26	22	
12LM 400/01DR10	75	55	106,2		53	52	42	40	38	36	32	28	
12LM 400/01	90	66	126,0		58	57	46	44	42	40	37	31	27
12LM 400/02DR30	100	75	143,2		86	84	64	59	54	48			
12LM 400/02DR20	125	92	175,1		94	90	73	69	65	59	52	44	
12LM 400/02DR10D	150	110	211,0		106	104	84	80	76	71	64	56	
12LM 400/02D	175	130	245,3		116	114	92	88	84	80	73	62	54
12LM 400/03DR20D	200	150	277,2		141	135	110	104	98	89	78	66	
12LM 400/03DR10D	225	165	313,3		159	156	126	120	114	107	96	84	
12LM 400/03D	250	185	342,2		174	171	138	132	126	120	110	93	81

Max Eff. % DR30 =	81,2
Max Eff. % DR20 =	81,8
Max Eff. % DR10 =	82,7
Max Eff. %	81,6
Max Eff. % A =	82,5
Max kW / St. DR30 =	37
Max kW / St. DR20 =	45,6
Max kW / St. DR10 =	53
Max kW / St.	60,4
Max kW / St. A =	67

NPSH (m)	Q=25%	Q=50%	Q=75%	Q=100%
	3,4	5	7,8	11,8

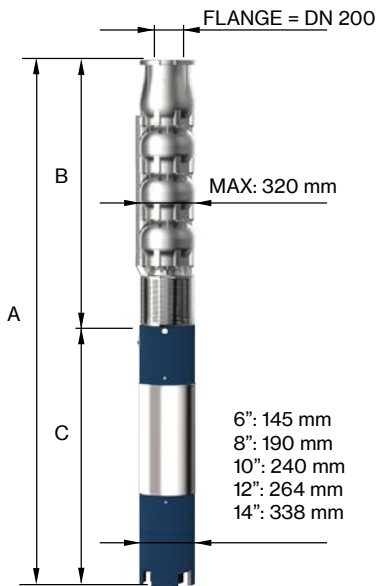

TYPE	MOTOR BRACKET	DIMENSIONS (mm)			WEIGHT (kg)	
		A	B	C	MOTOR	PUMP
12LM 400/01DR30-6	6" NEMA	2111	770	1341	118	79
12LM 400/01DR20-8	8" NEMA	2003	770	1233	200	79
12LM 400/01DR10-8		2003	770	1233	200	79
12LM 400/01-8		2072	770	1302	214	79
12LM 400/02DR30-8		2383	1000	1383	230	104
12LM 400/02DR20-8	2583	1000	1583	270	104	
12LM 400/02DR10D-8	2733	1000	1733	300	104	
12LM 400/02D-10	10"	2634	1000	1634	385	104
12LM 400/03DR20D-10		2964	1230	1734	415	129
12LM 400/03DR10D-10		3084	1230	1854	444	129
12LM 400/03D-10		3214	1230	1984	480	129

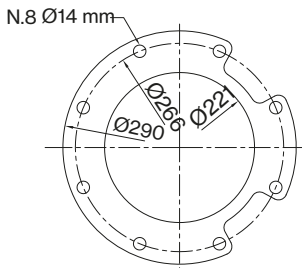

FOR COMMERCIAL TUBE  
EXTERNAL DIAMETER: 219,1 mm

"DR": reduced-diameter impellers  
"D" Pump shaft in Duplex EN 1.4462



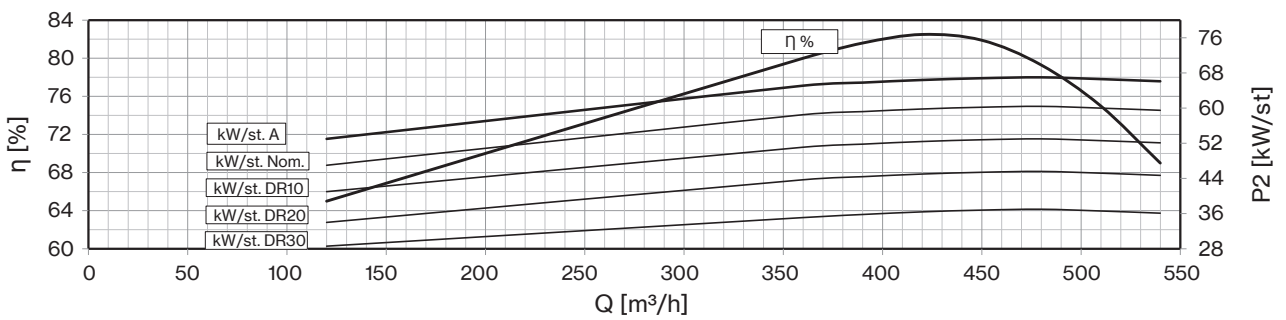
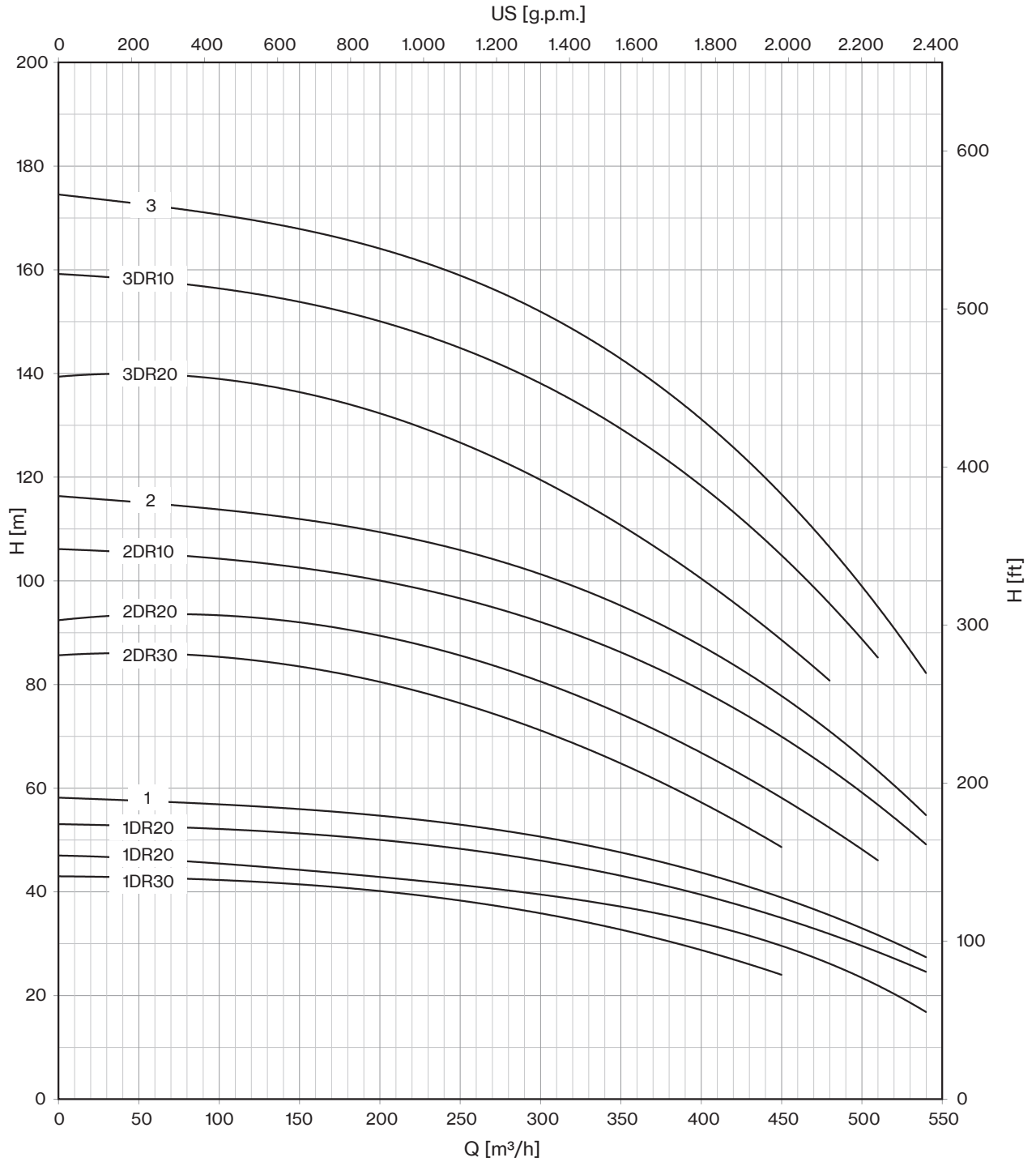

# 12LM 400

50 Hz - 2900 rpm				Q									
TYPE	SUITABLE MOTOR 3- 400V		I/min	0	2000	6000	6500	7000	7500	8000	8500	9000	
	P2		CURRENT	I/sec	0	33,3	100,0	108,3	116,7	125,0	133,3	141,7	150,0
	HP	kW	A	m³/h	0	120	360	390	420	450	480	510	540
12LM 400/04DR20D	250	185	342,2	H (m)	188	180	146	138	130	118	104	88	
12LM 400/04DR10D	300	220	430,0		212	208	168	160	152	142	128	112	
12LM 400/04D	340	250	481,0		232	228	184	176	168	160	146	124	108
12LM 400/05DR10D	400	300	551,0		265	260	210	200	190	178	160	140	
12LM 400/05D	450	330	620,0		290	285	230	220	210	200	183	155	135
12LM 400/05AD	500	370	693,0		305	300	250	240	230	223	205	195	160
12LM 400/06D	500	370	693,0		348	342	276	264	252	240	220	186	162

Max Eff. % DR30 =	81,2
Max Eff. % DR20 =	81,8
Max Eff. % DR10 =	82,7
Max Eff. %	81,6
Max Eff. % A =	82,5
Max kW / St. DR30 =	37
Max kW / St. DR20 =	45,6
Max kW / St. DR10 =	53
Max kW / St.	60,4
Max kW / St. A =	67

NPSH (m)	Q=25%	Q=50%	Q=75%	Q=100%
	3,4	5	7,8	11,8

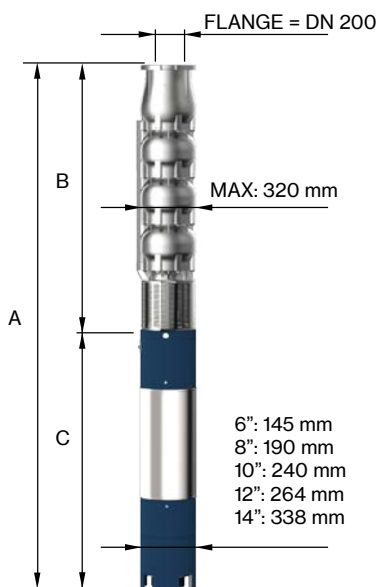

TYPE	MOTOR BRACKET	DIMENSIONS (mm)			WEIGHT (kg)	
		A	B	C	MOTOR	PUMP
12LM 400/04DR20D	12"	3444	1460	1984	480	154
12LM 400/04DR10D		3570	1460	2110	700	154
12LM 400/04D		3740	1460	2280	775	154
12LM 400/05 DR10D-14	14"	3970	1690	2280	775	179
12LM 400/05D-14		3850	1690	2160	906	179
12LM 400/05AD-14		4010	1690	2320	1010	179
12LM 400/06D-14		4240	1920	2320	1010	204

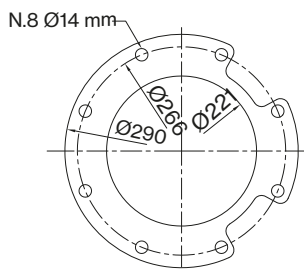

FOR COMMERCIAL TUBE  
EXTERNAL DIAMETER: 219,1 mm

"DR": reduced-diameter impellers  
"D" Pump shaft in Duplex EN 1.4462



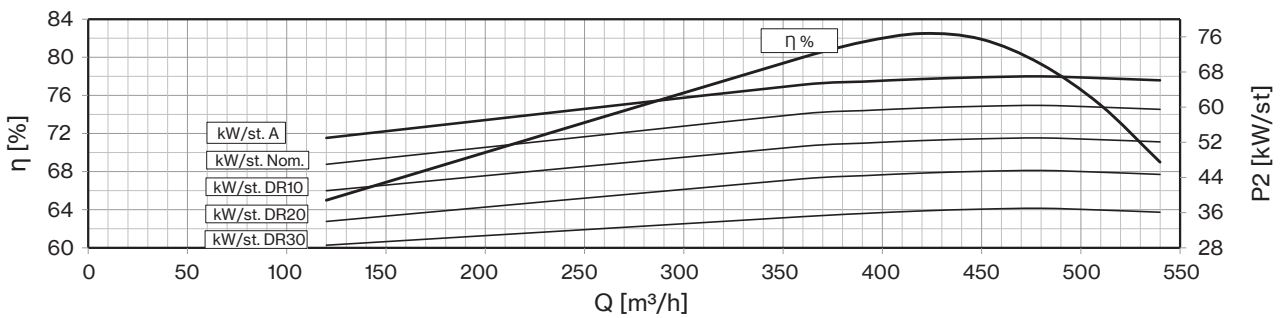
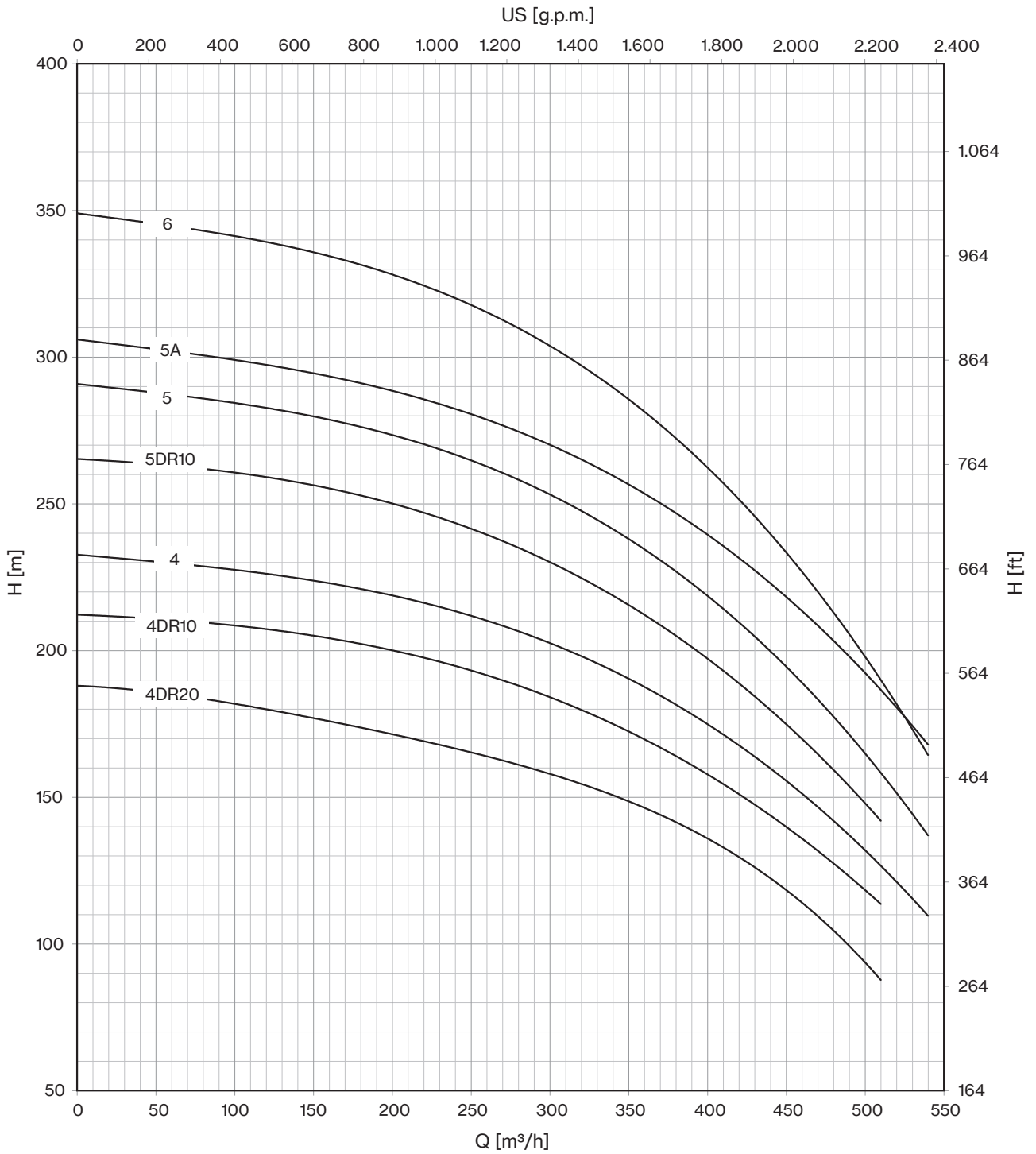

# 10LM-12LM

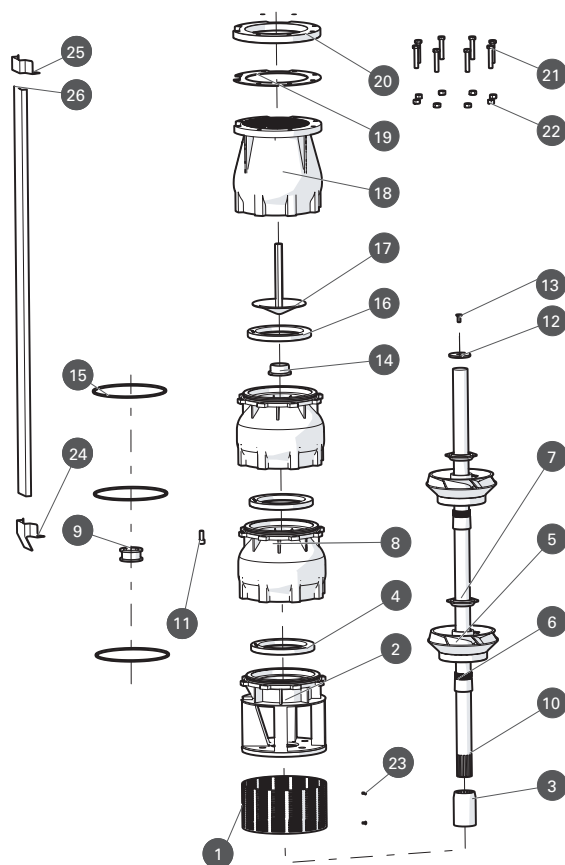

N. CODE	DESCRIPTION	LMS EXECUTION	LMX EXECUTION	LMD EXECUTION	(*) Q.TY
1	<b>SUCTION STRAINER</b>	AISI 304	AISI 316	Duplex EN 1.4462	-
2	<b>MOTOR BRACKET</b>	AISI 304	AISI 316	Duplex EN 1.4462	-
3	<b>COUPLING</b>	AISI 304	AISI 316	Duplex EN 1.4462	1
4	<b>WEAR RING</b>	NBR	NBR	NBR	N° of Stages
5	<b>IMPELLER</b>	AISI 304	AISI 316	Duplex EN 1.4462	-
6	<b>CONE</b>	AISI 304	AISI 316	Duplex EN 1.4462	N° of Stages
7	<b>HEXAGONAL RING</b>	AISI 304	AISI 316	Duplex EN 1.4462	N° of Stages
8	<b>DIFFUSER</b>	AISI 304	AISI 316	Duplex EN 1.4462	-
9	<b>BEARING BUSH</b>	NBR	NBR	NBR	N° of Stages
10	<b>PUMP SHAFT</b>	AISI 304	AISI 316	Duplex EN 1.4462	1
11	<b>N.8 SCREW FOR DIFFUSEUR</b>	AISI 304	AISI 316	Duplex EN 1.4462	-
12	<b>RING</b>	AISI 304	AISI 316	Duplex EN 1.4462	1
13	<b>SCREW FOR DISK</b>	AISI 304	AISI 316	Duplex EN 1.4462	1
14	<b>COUNTERTHRUST</b>	PTFE + 25% CARBON	PTFE + 25% CARBON	PTFE + 25% CARBON	1
15	<b>O-RING</b>	NBR	NBR	NBR	N° of Stages
16	<b>GASKET VALVE</b>	NBR	NBR	NBR	1
17	<b>CAP VALVE</b>	AISI 304	AISI 316	Duplex EN 1.4462	-
18	<b>BODY VALVE</b>	AISI 304	AISI 316	Duplex EN 1.4462	-
19	<b>SEAL COUNTERFLANGE</b>	NBR	NBR	NBR	1
20	<b>COUNTERFLANGE</b>	AISI 304	AISI 316	Duplex EN 1.4462	-
21	<b>N.8 SCREW FOR COUNTERFLANGE</b>	AISI 304	AISI 316	Duplex EN 1.4462	-
22	<b>N.8 NUT FOR COUNTERFLANGE</b>	AISI 304	AISI 316	Duplex EN 1.4462	-
23	<b>N.2 SCREW FOR SUCTION STRAINER</b>	AISI 304	AISI 316	Duplex EN 1.4462	-
24	<b>LOWER CLAMP</b>	AISI 304	AISI 316	Duplex EN 1.4462	-
25	<b>UPPER CLAMP</b>	AISI 304	AISI 316	Duplex EN 1.4462	-
26	<b>COVER CABLE</b>	AISI 304	AISI 316	Duplex EN 1.4462	-

\* Recommended spare parts quantity

