

6R/8R/10R

6", 8", 10" rewindable submersible water-filled motors with NEMA coupling flange and shaft end. Power from 4 kW up to 185 kW. Available in PPC (standard), LPE and PE2+PA. The motor can be supplied in AISI 304, AISI 316 or Duplex EN 1.4462.

Construction features	
Upper and bottom support	G25 (6R / 8R / 10R) AISI 304 (6RS / 8RS / 10RS) AISI 316 (6RX / 8RX / 10RX) Duplex EN 1.4462 (6RD / 8RD / 10RD)
Stator sleeve	stainless steel AISI 304 (R) stainless steel AISI 304 (RS) stainless steel AISI 316 (RX) Duplex EN 1.4462 (RD)
Shaft end	stainless steel AISI 431 (R) stainless steel AISI 431 (RS) stainless steel AISI 316 (RX) Duplex EN 1.4462 (RD)
Seal type	lip seal (standard); mechanical seal (on request)
Bearings	radial and axial, water lubricated
Thrust bearing	Michell
Voltage	3~ 400V ± 10% - 60Hz 3~ 400/690V ± 10% - 60Hz
Min. cooling flow	0,5 m/s
Insulation class	Y (max 30° C) for PPC F (max 50° C) for PE2+PA or LPE
Insulation	PPC (standard) PE2 + PA or LPE (on request)
Protection degree	IPX8
Max depth immersion	350m
Available on demand	- PT 100 - Star/Delta starting - Cooling Sleeve - Cer./Carb./NBR Seal - SIC/SIC/NBR Seal

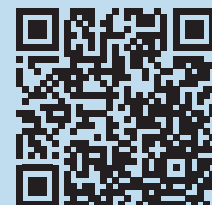
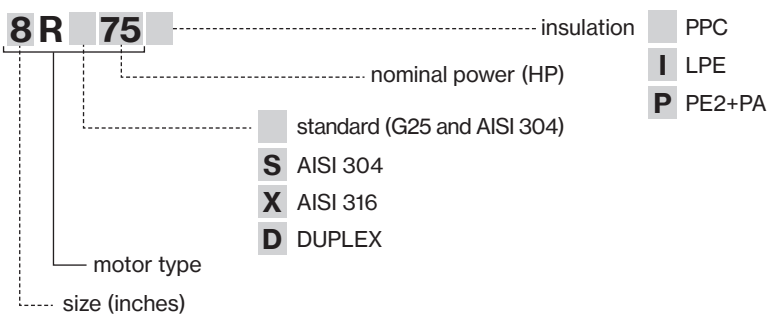
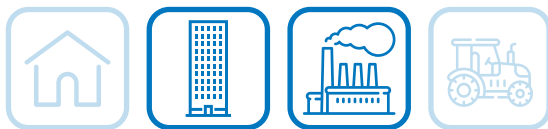

6R-6RS-6RX-6RD

TYPE	Power		V	I _N A	rpm	Efficiency %			Cos φ			Starting				Axial load N	Start/ hour (max)
	HP	kW				50%	75%	100%	50%	75%	100%	Direct		Star-delta	Statoric		
			Cs/Cn	Is / In	Is / In	Is / In											
6R7	7,5	5,5	230	21,3	3427	77	82	81	0,67	0,78	0,83	1,60	5,60	1,90	3,40	16000	15
			400	12,3	3435	76	81	80	0,65	0,76	0,81						
			460	10,7	3441	75	80	79	0,63	0,74	0,79						
6R10	10	7,5	230	28,2	3428	78	82,5	82	0,68	0,78	0,84	1,80	5,70	1,90	3,40		
			400	16,3	3435	77	81,5	81	0,66	0,76	0,82						
			460	14,3	3439	76	80,5	80	0,64	0,74	0,80						
6R12	12,5	9,2	230	34,4	3431	79	83	82	0,68	0,79	0,85	1,80	5,70	1,90	3,40		
			400	19,9	3437	78	82	81	0,66	0,77	0,83						
			460	17,3	3443	77	81	80	0,64	0,75	0,81						
6R15	15	11	230	40,5	3431	80	84,5	83,5	0,69	0,79	0,85	1,90	5,90	2,00	3,50		
			400	23,4	3439	79	83,5	82,5	0,67	0,77	0,83						
			460	20,3	3446	78	82,5	81,5	0,65	0,75	0,81						
6R17	17,5	13	230	47,2	3435	80	84,5	84	0,69	0,79	0,85	1,80	6,00	2,00	3,60		
			400	27,3	3440	80	83,5	83	0,67	0,77	0,83						
			460	23,7	3446	79	82,5	82	0,65	0,75	0,81						
6R20	20	15	230	55	3435	82	85	84	0,69	0,79	0,85	1,70	5,90	2,00	3,50		
			400	31,5	3440	81	84	83	0,67	0,77	0,83						
			460	27,4	3446	80	83	82	0,65	0,75	0,81						
6R25	25	18,5	230	66,2	3440	82	85,5	85	0,69	0,79	0,85	1,70	5,60	1,90	3,40		
			400	38,3	3446	81	84,5	84	0,67	0,77	0,83						
			460	33,3	3449	80	83	82,5	0,65	0,75	0,81						
6R30	30	22	230	78	3437	82,5	85,5	85	0,70	0,80	0,86	1,70	5,90	2,00	3,50		
			400	45,1	3448	81,5	84,5	84	0,68	0,78	0,84						
			460	39,2	3453	80	83	82,5	0,66	0,76	0,82						
6R35	35	26	230	91,5	3440	82,5	86	85,5	0,71	0,81	0,86	1,70	5,70	1,90	3,40		
			400	52,9	3449	81,5	85	84,5	0,69	0,79	0,84						
			460	46	3457	80	83,5	83,0	0,67	0,77	0,82						
6R40	40	30	230	106	3446	82,5	86,0	85,5	0,72	0,81	0,86	1,70	5,60	1,90	3,40		
			400	61,1	3453	81,5	85,0	84,5	0,70	0,79	0,84						
			460	53,2	3460	80	83,5	83	0,68	0,77	0,82						
6R50	50	37	230	131	3451	83	86,5	85	0,72	0,81	0,86	1,60	5,60	1,90	3,40		
			400	75,8	3457	82	85,5	84	0,70	0,79	0,84						
			460	66	3464	80,5	84	82,5	0,68	0,77	0,82						

Service factor: 60Hz=1 - Direction of rotation (view from shaft projection side: anti-clockwise)

Cs = Starting torque - Cn = Nominal couple - Is = Starting current - In = Nominal current

TYPE	Power		Cables		Cable length m	Max water temperature by winding type	
	HP	kW	Starting			PPC	PE2-PA / LPE
			Direct 460 V ± 5%	Star Delta 460 / 800 V			
6R7	7,5	5,5	4G × 4 mm ²	2 × (4G × 4 mm ²)	3	30 °C	50 °C
6R10	10	7,5	4G × 4 mm ²	2 × (4G × 4 mm ²)			
6R12	12,5	9,2	4G × 4 mm ²	2 × (4G × 4 mm ²)			
6R15	15	11	4G × 4 mm ²	2 × (4G × 4 mm ²)			
6R17	17,5	13	4G × 6 mm ²	2 × (4G × 4 mm ²)			
6R20	20	15	4G × 6 mm ²	2 × (4G × 4 mm ²)			
6R25	25	18,5	4G × 6 mm ²	2 × (4G × 4 mm ²)			
6R30	30	22	4G × 6 mm ²	2 × (4G × 4 mm ²)			
6R35	35	26	4G × 10 mm ²	2 × (4G × 6 mm ²)			
6R40	40	30	4G × 10 mm ²	2 × (4G × 6 mm ²)			
6R50	50	37	4G × 10 mm ²	2 × (4G × 6 mm ²)			

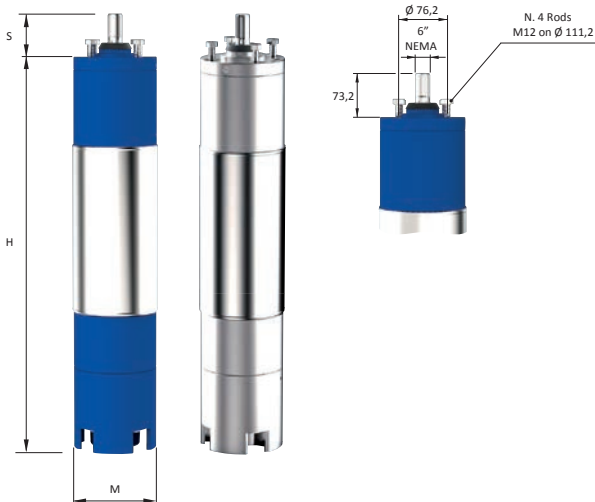

TYPE	DIMENSIONS			Kg
	H	S	M	
	mm			
6R7	671	73,2	145	45
6R10	701			55
6R12	751			60
6R15	811			65
6R17	841			70
6R20	931			75
6R25	991			83
6R30	1071			92
6R35	1181			100
6R40	1251			108
6R50	1341	118		



8R-8RS-8RX-8RD

TYPE	Power		V	I _N A	rpm	Efficiency %			Cos φ			Starting				Axial load N	Start/hour (max)
	HP	kW				50%	75%	100%	50%	75%	100%	Direct		Star-delta	Statoric		
			Cs/Cn	Is / In	Is / In							Is / In					
8R40	40	30	230	106,5	3436	79,8	85,2	84,3	0,77	0,81	0,84	2,05	6,40	2,10	3,80	45000	10
			400	61,7	3445	80,1	85	84,7	0,76	0,80	0,83						
			460	54	3456	79,3	84,5	85	0,75	0,79	0,82						
8R50	50	37	230	126	3439	80,3	85,7	84,8	0,79	0,83	0,88	1,95	5,70	2	3,70		
			400	73	3449	80,6	85,5	85,2	0,77	0,81	0,86						
			460	63,5	3457	79,8	85	85,5	0,75	0,79	0,84						
8R60	60	45	230	149	3457	80,8	86,2	85,3	0,76	0,86	0,87	1,95	5,80	2	3,70		
			400	86,3	3462	81,1	86	85,7	0,74	0,81	0,86						
			460	75,1	3469	80,3	85,5	86	0,72	0,79	0,84						
8R75	75	55	230	184	3461	81,3	86,7	85,8	0,76	0,85	0,89	1,85	5,80	2	3,60		
			400	106,2	3468	81,6	86,5	86,2	0,74	0,81	0,87						
			460	92,2	3472	80,8	86	86,5	0,72	0,80	0,84						
8R90	90	66	230	218	3463	82,4	87,5	86,8	0,76	0,86	0,89	1,85	5,80	2	3,50		
			400	126	3469	82,6	87,4	87,2	0,74	0,82	0,87						
			460	109,6	3473	81,9	86,9	87,5	0,72	0,79	0,84						
8R100	100	75	230	247,7	3462	82,3	87,7	86,8	0,75	0,85	0,89	1,80	5,80	2	3,50		
			400	143,2	3470	82,6	87,5	87,2	0,73	0,81	0,87						
			460	124,6	3476	81,8	87	87,5	0,71	0,77	0,84						
8R125	125	92	230	302,9	3465	83	86	85,7	0,75	0,84	0,89	1,80	5,70	1,90	3,50		
			400	175,1	3472	83,5	86,5	86,3	0,74	0,83	0,88						
			460	152,3	3478	83	86	86,3	0,72	0,81	0,86						
8R150	150	110	230	366,1	3467	85,5	86,5	86	0,74	0,83	0,89	1,80	5,70	1,90	3,50		
			400	211	3473	86,1	87	86,6	0,73	0,82	0,87						
			460	183,6	3478	85,5	86,5	86	0,72	0,81	0,84						

Service factor: 60Hz=1 - Direction of rotation (view from shaft projection side: anti-clockwise)
Cs = Starting torque - Cn = Nominal couple - Is = Starting current - In = Nominal current

TYPE	Power		Cables		Cable lenght m	Max water temperature by winding type	
	HP	kW	Starting			PPC	PE2-PA / LPE
			Direct 460 V ± 5%	Star Delta 460 / 800 V			
8R40	40	30	3 × 1 × 10 mm ²	6 × 1 × 10 mm ²	5	30 °C	50 °C
8R50	50	37	3 × 1 × 10 mm ²	6 × 1 × 10 mm ²			
8R60	60	45	3 × 1 × 16 mm ²	6 × 1 × 10 mm ²			
8R75	75	55	3 × 1 × 16 mm ²	6 × 1 × 10 mm ²			
8R90	90	66	3 × 1 × 25 mm ²	6 × 1 × 16 mm ²			
8R100	100	75	3 × 1 × 25 mm ²	6 × 1 × 16 mm ²			
8R125	125	92	3 × 1 × 25 mm ²	6 × 1 × 16 mm ²			
8R150	150	110	3 × 1 × 35 mm ²	6 × 1 × 25 mm ²			

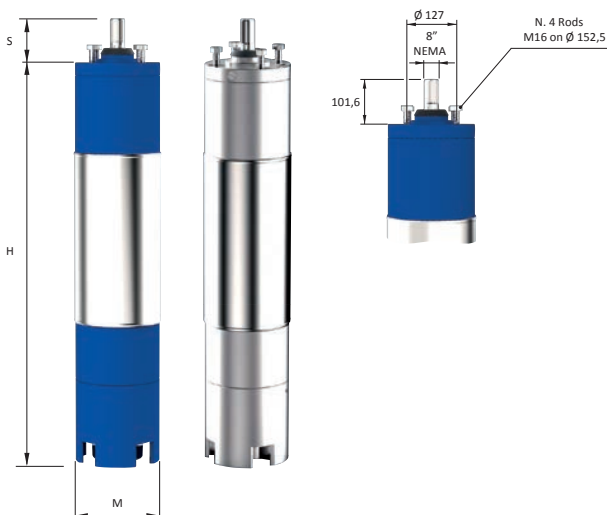

TYPE	DIMENSIONS			Kg
	H	S	M	
	mm			
8R40	993	101,6	194	150
8R50	1043			160
8R60	1123			178
8R75	1233			200
8R90	1302			214
8R100	1383			230
8R125	1583			270
8R150	1733			300



10R-10RS-10RX-10RD

TYPE	Power		V	I _N	rpm	Efficiency %			Cos φ			Starting				Axial load N	Start/ hour (max)				
	HP	kW				A	50%	75%	100%	50%	75%	100%	Direct		Star-delta			Statoric			
			Cs/Cn	Is / In	Is / In								Is / In								
10R100	100	75	230	247	3460	86,9	87	88	0,73	0,80	0,84	1,80	6,40	1,90	3,40	60000	10				
			400	142,7	3465	85,9	88	88,3	0,72	0,84	0,86										
			460	124	3470	86,4	88,3	88,5	0,64	0,77	0,82										
10R125	125	92	230	303	3462	87,2	87,3	88,3	0,74	0,83	0,84	1,80	6,40	1,90	3,40			60000	10		
			400	174,5	3469	86,2	88,3	88,6	0,71	0,83	0,86										
			460	152	3474	86,7	88,6	88,8	0,63	0,75	0,82										
10R150	150	110	230	358	3465	87,9	88	89	0,71	0,81	0,85	1,60	6,30	1,80	3,40					60000	10
			400	207	3470	86,9	89	89,3	0,73	0,84	0,86										
			460	180	3475	87,4	89,3	89,5	0,63	0,77	0,81										
10R175	175	130	230	423	3469	87,5	88,2	89	0,73	0,81	0,83	1,55	6,70	1,80	3,30						
			400	245,3	3475	86,5	89,3	89,4	0,71	0,83	0,85										
			460	213	3482	87,1	89,5	89,6	0,62	0,75	0,82										
10R200	200	150	230	480	3475	87,1	88,2	89	0,72	0,82	0,84	1,55	6,50	1,80	3,30	60000	10				
			400	277,2	3483	86,1	88,5	89,1	0,71	0,81	0,86										
			460	241	3488	86,5	88,1	88,7	0,65	0,75	0,83										
10R225	225	165	230	542	3478	86,5	87,5	88,6	0,72	0,82	0,84	1,55	6,50	1,80	3,30			60000	10		
			400	313,3	3488	85,4	87,2	88,5	0,71	0,81	0,86										
			460	273	3492	86,0	87,3	88,2	0,65	0,75	0,83										
10R250	250	185	230	590	3480	87,4	88	89	0,73	0,83	0,85	1,50	6,50	1,80	3,30					60000	10
			400	342,2	3490	86,5	88,7	89,3	0,72	0,82	0,87										
			460	298	3496	87,3	89,3	89,5	0,65	0,77	0,84										

Service factor: 60Hz=1 - Direction of rotation (view from shaft projection side: anti-clockwise)

Cs = Starting torque - Cn = Nominal couple - Is = Starting current - In = Nominal current

TYPE	Power		Cables		Cable length	Max water temperature by winding type	
	HP	kW	Starting			m	PPC
			Direct	Star Delta			
			460 V ± 5%	460 / 800 V			
10R100	100	75	3 × 1 × 25 mm ²	6 × 1 × 16 mm ²	5	30 °C	50 °C
10R125	125	92	3 × 1 × 25 mm ²	6 × 1 × 16 mm ²			
10R150	150	110	3 × 1 × 35 mm ²	6 × 1 × 16 mm ²			
10R175	175	130	3 × 1 × 35 mm ²	6 × 1 × 25 mm ²			
10R200	200	150	3 × 1 × 50 mm ²	6 × 1 × 25 mm ²			
10R225	225	165	3 × 1 × 50 mm ²	6 × 1 × 35 mm ²			
10R250	250	185	3 × 1 × 50 mm ²	6 × 1 × 35 mm ²			

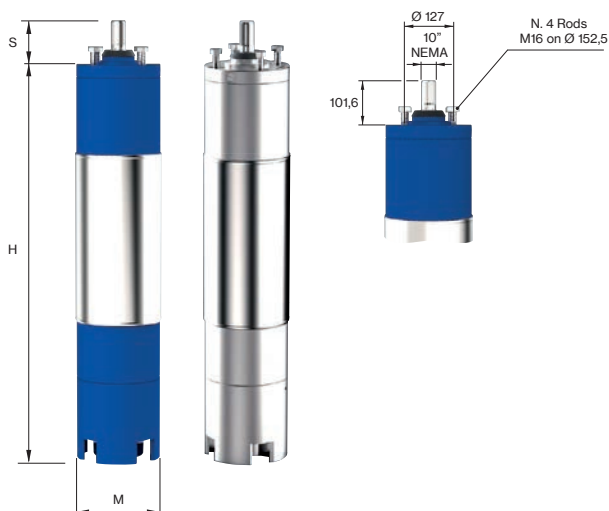

TYPE	DIMENSIONS			Kg
	H	S	M	
	mm			
10R100	1284	101,6	240	270
10R125	1354			310
10R150	1504			350
10R175	1634			385
10R200	1734			415
10R225	1854			444
10R250	1984			480



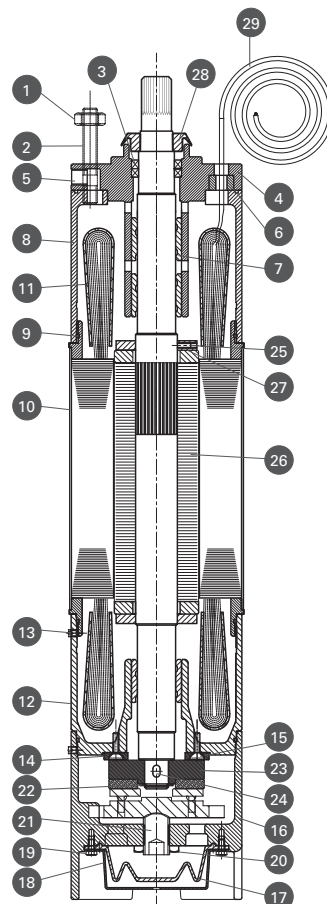

N. CODE	(*) N°	DESCRIPTION	MATERIAL STANDARD VERSION R	MATERIAL VERSION RS-RX-RD
1		N.4 NUTS	AISI 304	AISI 304 / AISI 316 / DUPLEX
2		N.4 STUDS	AISI 304	AISI 304 / AISI 316 / DUPLEX
3(*)	1	N.2 SEAL RINGS	NBR	NBR
4		UPPER SUPPORT	CAST IRON	AISI 304 / AISI 316 / DUPLEX
5		N.2 GRAINS FOR LIQUID FILLING	AISI 304	AISI 304 / AISI 316 / DUPLEX
6		GROMMET	NBR	NBR
7(*)	3	N.3 BEARINGS	GRAPHITE	GRAPHITE
8		MOTOR CASING	CAST IRON	AISI 304 / AISI 316 / DUPLEX
9(*)	4	N.4 O-RING	NBR	NBR
10		MOTOR EXTERNAL SLEEVE	AISI 304	AISI 304 / AISI 316 / DUPLEX
11		N.2 COVERS WINDING PROTECTION	POM	POM
12		LOWER SUPPORT	CAST IRON	AISI 304 / AISI 316 / DUPLEX
13		N.3 SCREW	AISI 304	AISI 304 / AISI 316 / DUPLEX
14(*)	2	N.2 DISKS CONTROSUSPENTION	TEFLON	TEFLON
15		N.2 SCREWS FOR CONTROSUSPENTION	AISI 304	AISI 304
16		BASE MOTOR	CAST IRON	AISI 304 / AISI 316 / DUPLEX
17(*)	1	DIAPHRAM	NBR	NBR
18		COVER DIAPHRAM	AISI 304	AISI 304 / AISI 316 / DUPLEX
19		N.4 SCREW FOR COVER DIAPHRAM	AISI 304	AISI 304 / AISI 316 / DUPLEX
20		NUT	AISI 304	AISI 304
21		SCREW	AISI 304	AISI 304
22		SEEGER	AISI 304	AISI 304
23(*)	1	TRUST BEARING	AISI + GRAPHITE	AISI + GRAPHITE
24		KEY	AISI 304	AISI 304
25		N.2 GRAINS FOR STABILIZER	AISI 304	AISI 304
26		COMPLETE ROTOR	AISI	AISI
27		N.2 STABILIZERS	AISI	AISI
28(*)	1	DEFLECTOR	NBR	NBR
29		CABLE	H07 RNF	H07 RNF

*Reccomended spare parts



6R/8R/10R

OPERATING CONDITIONS AT DIFFERENT WATER TEMPERATURE

All 6" - 8" - 10" standard motors with PPC windings can operate at liquid temperatures up to 30 °C without derating factor. From 31 °C till 43 °C the motors have to be derated according to the factor shown in the following graph.

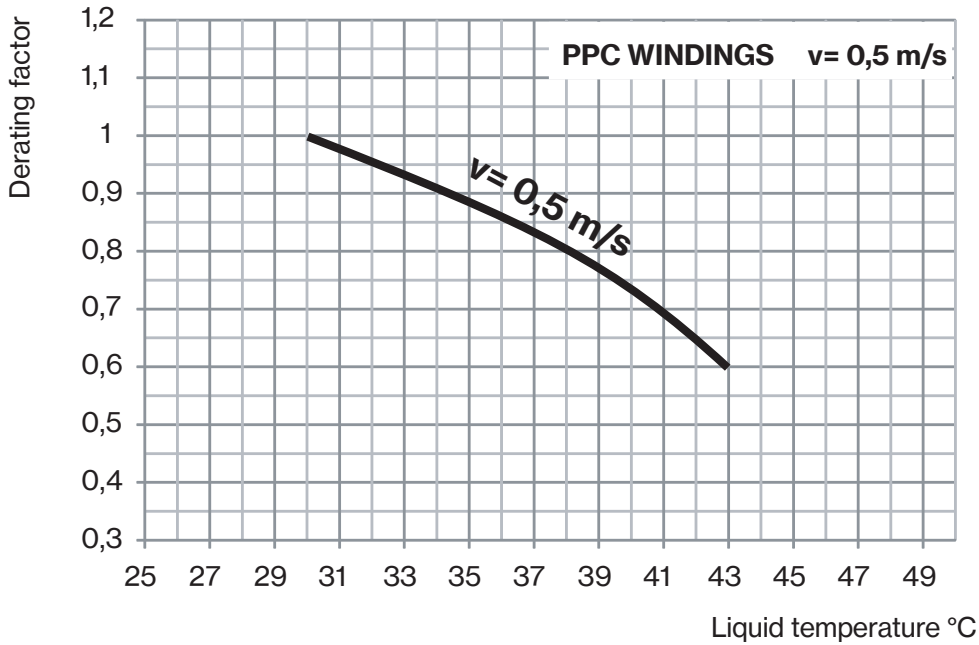

All 6" - 8" - 10" motors with PE2+PA / LPE windings can operate at liquid temperatures up to 50 °C without derating factor. From 51 °C till 64 °C the motors have to be derated according to the factor shown in the following graph.

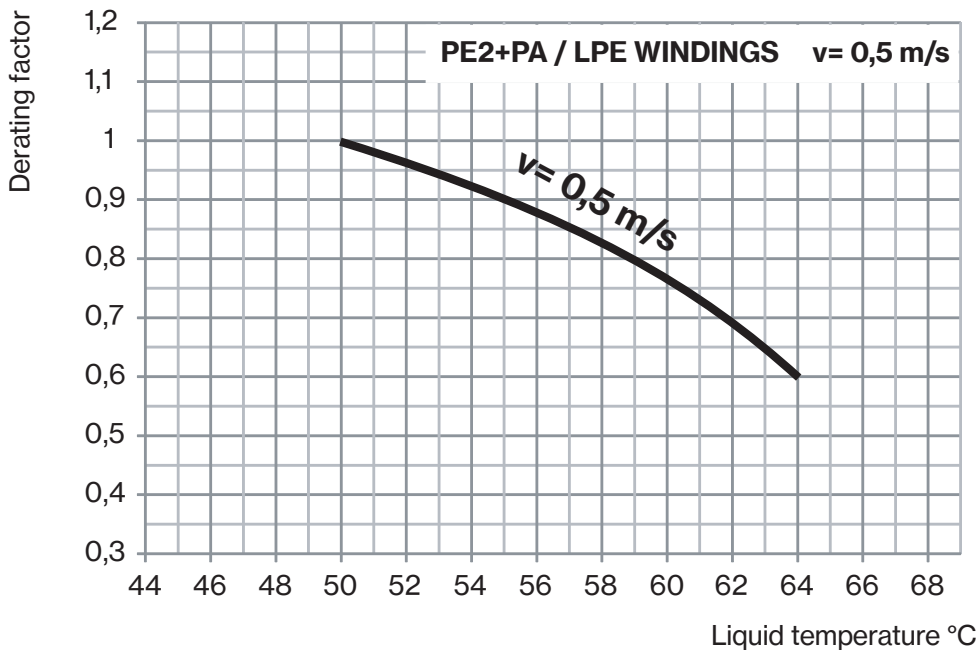

Motor size	Max motor starts per hour	Winding max temperature (°C)			Liquid max temperature (°C)		
		PPC	LPE	PE2+PA	PPC	LPE	PE2+PA
6"	15	70	80	80	30	50	50
8"	10	70	80	80	30	50	50
10"	10	70	80	80	30	50	50

PPC = Y insulation class
 LPE = F insulation class
 PE2+PA = / F insulation class
 Minimum liquid velocity for motor 6" - 8" - 10": 0,5 m/s

