

DTR/DTRT

Sewage
Grinder



Drainage and waste water pumps equipped with open impeller and grinder system able to shred sewage with suspended solids and prevent the pump from clogging. Best for emptying of septic tanks and residential sumps as well as for rain water systems and for draining of flooded areas where seamless operation is required. The quick coupling feet DN50 and DN65 is available for flanged pumps.



Construction features

Painting	cataphoresis
Pump body	cast iron
Shell, motor cover	cast iron
Impeller	cast iron
Mechanical seal	double seal with oil barrier: silicon carbide on pump side, sealing ring on motor side.
Motor shaft	stainless steel AISI 304
Max submergence	20 m
Liquid temperature	0-40 °C



Grinder treated stainless steel

Bolts	A2 stainless steel
Foot support	galvanized iron
Gaskets	NBR rubber

Motor

2 Poles induction motor	3- 220V - 60Hz
	3- 380V - 60Hz
	3- 220/380V - 60Hz
	1- 220V - 60Hz (required run capacitor (35µF for 1,5HP model, 50µF for 2HP model))
Insulation class	F
Protection degree	IPX8

TYPE	LOTS			
	TRUCK		CONTAINER	
	PALLET (cm)	N° pumps	PALLET (cm)	N° pumps
DTRT 150÷300	85×110×145	18	85×110×190	27
DTRT 400-550	85×110×170	12	85×110×170	12
DTRT 750-1000	100×120×190	12	100×120×190	12

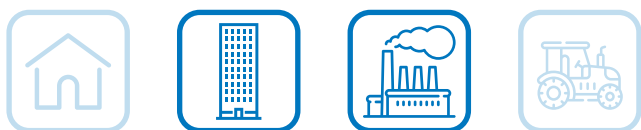
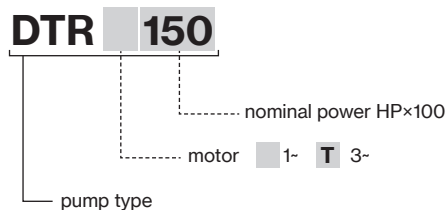

DTR/DTRT

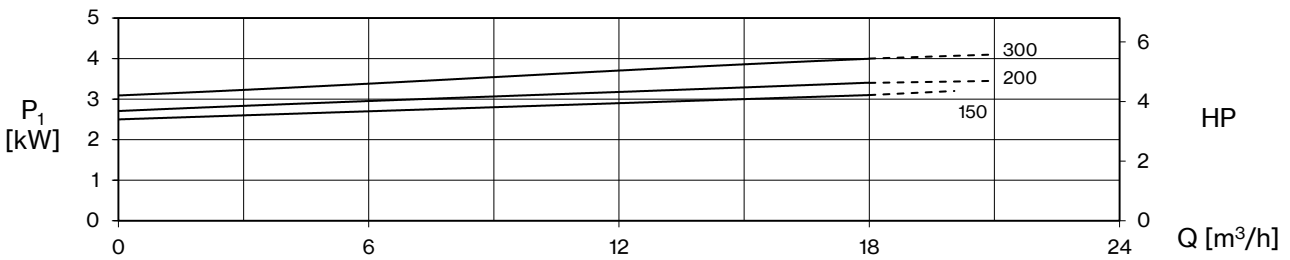
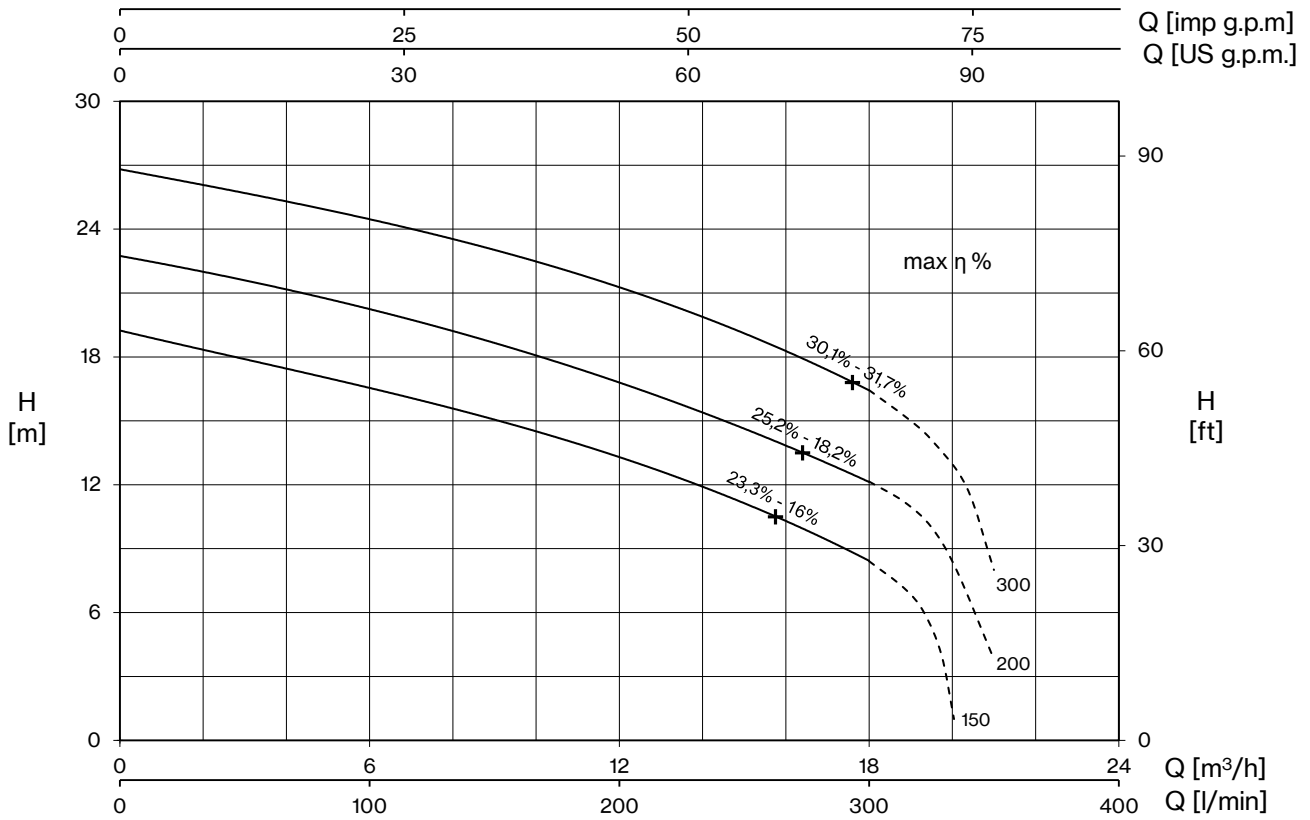

TYPE - 60 Hz		CURRENT			
1~	3~	220V	3~ 220V	3~ 380V (*)	220/380 V λ / Δ
DTR 150	DTRT 150	16,2	9,4	5,4	-
DTR 200	DTRT 200	17,5	10,2	5,9	-
-	DTRT 300	-	12,6	7,3	-

+ max η %

max hydraulic efficiency and respective total efficiency

(*) no standard execution

TYPE - 60 Hz		P2		P1		Q (m³/h - l/min)							
1~	3~	HP	kW	1~	3~	0	3	6	9	12	13,2	15	18
						0	50	100	150	200	220	250	300
				kW		H (m)							
DTRT 150	DTRT 150	1,5	1,1	3,4	3,1	19,2	18,0	16,5	15,0	13,3	12,5	11,2	8,4
DTRT 200	DTRT 200	2	1,5	3,7	3,4	22,7	21,7	20,2	18,6	16,8	16,0	14,7	12,1
-	DTRT 300	3	2,2	-	4,0	26,8	25,7	24,5	23,0	21,2	20,5	19,2	16,4



DTR/DTRT

Q [imp g.p.m]
Q [US g.p.m.]

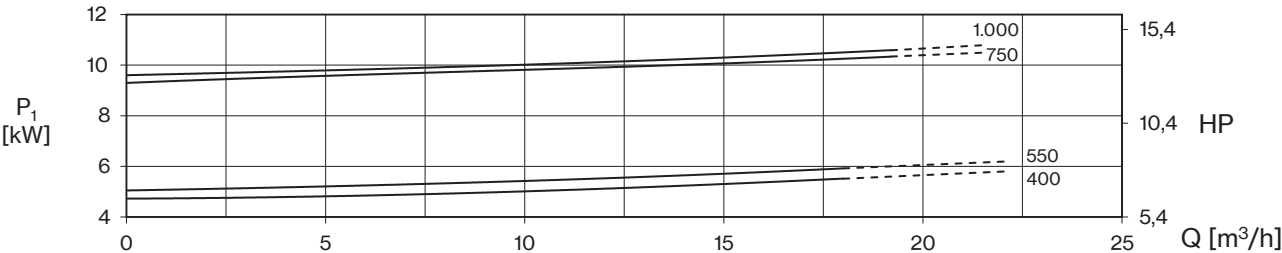
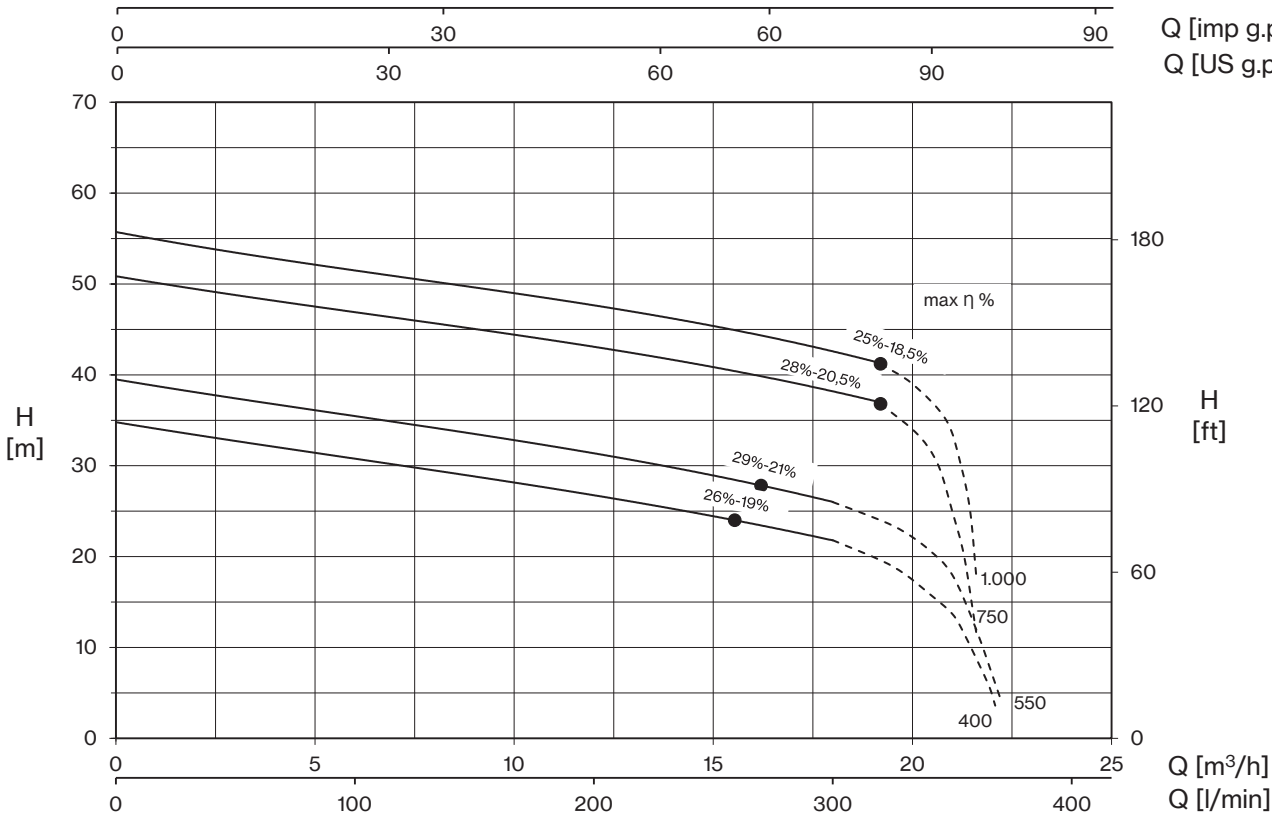

TYPE - 60 Hz	CURRENT			
	3~	3~ 220V	3~ 380V (*)	220/380 V λ / Δ
DTRT 400		15,9	9,2	-
DTRT 550		18,2	10,5	-
DTRT 750		-	18,8	32,5
DTRT 1000		-	19,0	32,9

+ max η %

max hydraulic efficiency and respective total efficiency

(*) no standard execution

TYPE - 60 Hz	P2		P1	Q (m³/h - l/min)						
				0	3	6	9	12	15	18
	HP	kW	kW	0	50	100	150	200	250	300
DTRT 400	4	3	5,1	34,8	32,7	30,8	28,8	26,8	24,4	21,8
DTRT 550	5,5	4	5,9	39,5	37,4	35,5	33,5	31,3	29,0	26,0

TYPE - 60 Hz	P2		P1	Q (m³/h - l/min)							
				0	3	6	9	12	15	18	19,2
	HP	kW	kW	0	50	100	150	200	250	300	320
DTRT 750	7,5	5,5	10,3	50,8	48,9	46,9	45,0	43,0	40,9	38,4	36,8
DTRT 1000	10	7,5	10,6	55,7	53,5	51,5	49,6	47,6	45,4	42,7	41,2



DTR/DTRT

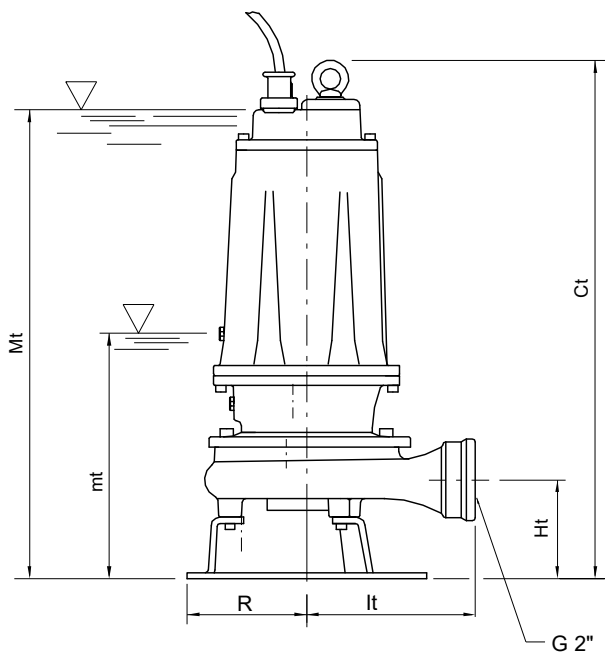

mt: minimum working level
Mt: minimum submersion level for continuous duty

TYPE		DIMENSIONS (mm)							Kg
1-	3-	Ct	Ht	R	lt	mt	Mt	DNM	
DTR 150	DTRT 150	513	102	117	174	205	475	2" G	37,5
DTR 200	DTRT 200	513	102	117	174	205	475	2" G	38,5
-	DTRT 300	513	102	117	174	205	475	2" G	38

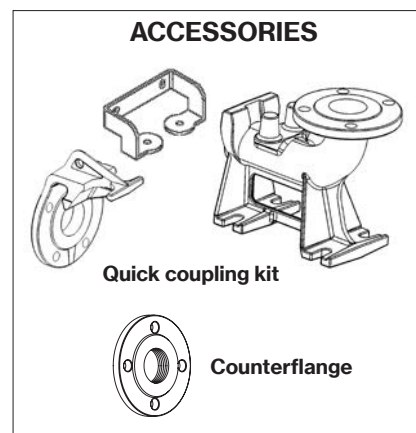
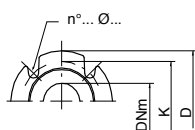
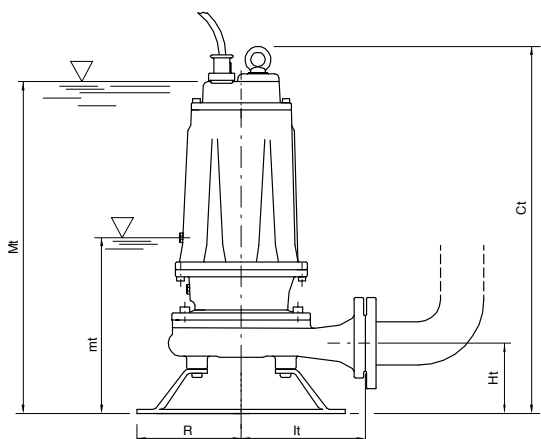

mt: minimum working level
Mt: minimum submersion level for continuous duty

TYPE	DIMENSIONS (mm)							Kg
	Ct	Ht	R	lt	mt	Mt	DNM	
DTRT 400	595	112	160	190	265	550	50	61,5
DTRT 550	595	112	160	190	265	550	50	65,5
DTRT 750	680	160	180	250	280	630	65	91,5
DTRT 1000	680	160	180	250	280	630	65	94,5



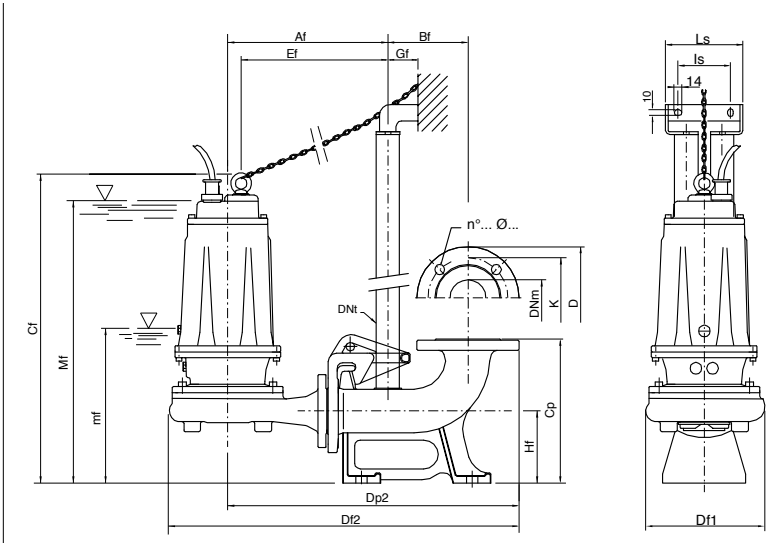

mf: minimum working level
 Mf: minimum submersion level for continuous duty

TYPE	DIMENSIONS (mm)																		
	Af	Bf	Cf	Cp	Df1	Df2	Dp2	Dnt	Ef	Gf	Hf	l1	l2	l3	Ls	mf	Mf	DNM	
DTRT 400/P	300	145	614	260	237	654	538	1" 1/4	269	55	130	200	100	95	140	290	566	50	
DTRT 550/P	300	145	614	260	237	654	538	1" 1/4	269	55	130	200	100	95	140	290	566	50	
DTRT 750/P	331	145	656	260	279	710	569	1" 1/4	297	55	130	200	100	95	140	290	600	65	
DTRT 1000/P	331	145	656	260	279	710	569	1" 1/4	297	55	130	250	100	95	140	290	600	65	

Flange UNI PN 10 (mm)			
DNM	K	D	n°... ø...
50	125	165	4... 18...
65	145	185	4... 18...

