

Drainage pumps for charged liquids with set-back Vortex type impeller for civil and industrial applications; specifically designed for very heavy use; available in the mobile or permanent versions with coupling feet.

Construction features

Painting	cataphoresis
Pump body	cast iron
	Impeller cast iron
Mechanical seal	double seal with oil barrier: silicon carbide on pump side, ceramic-graphite on motor side
Motor shaft	stainless steel AISI 304
Free passage	Ø max 50 mm
Max submergence	20 m
Liquid temperature	0 - 40 °C
Cable	H07 RN8F, 10 m
Bolts	A2 stainless steel
Foot support	galvanized iron
Gaskets	NBR rubber

Motor

4 poles induction motor	3~ 230V - 50Hz 3~ 400V - 50Hz 3~ 230/400V - 50Hz 3~ 400/690V - 50Hz
Insulation class	F
Protection degree	IPX8

TYPE	LOTS			
	TRUCK		CONTAINER	
	PALLET (cm)	N° pumps	PALLET (cm)	N° pumps
DVT 250-4÷750-4	85×110×190	8	100×120×190	12

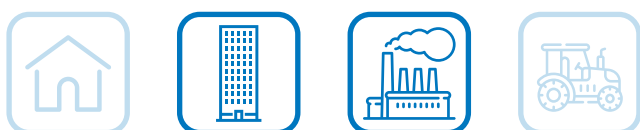
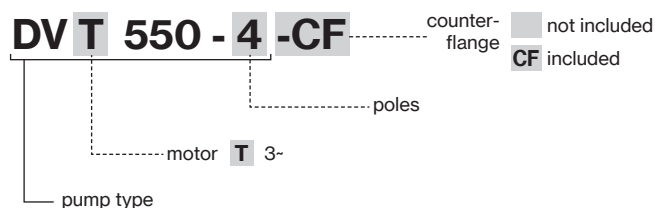

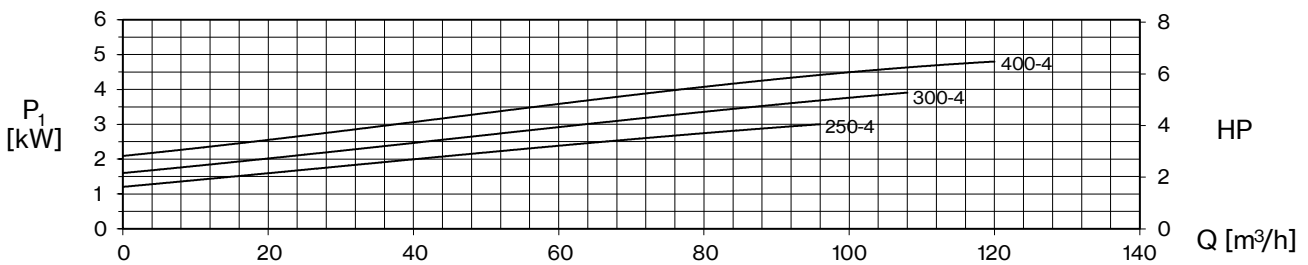
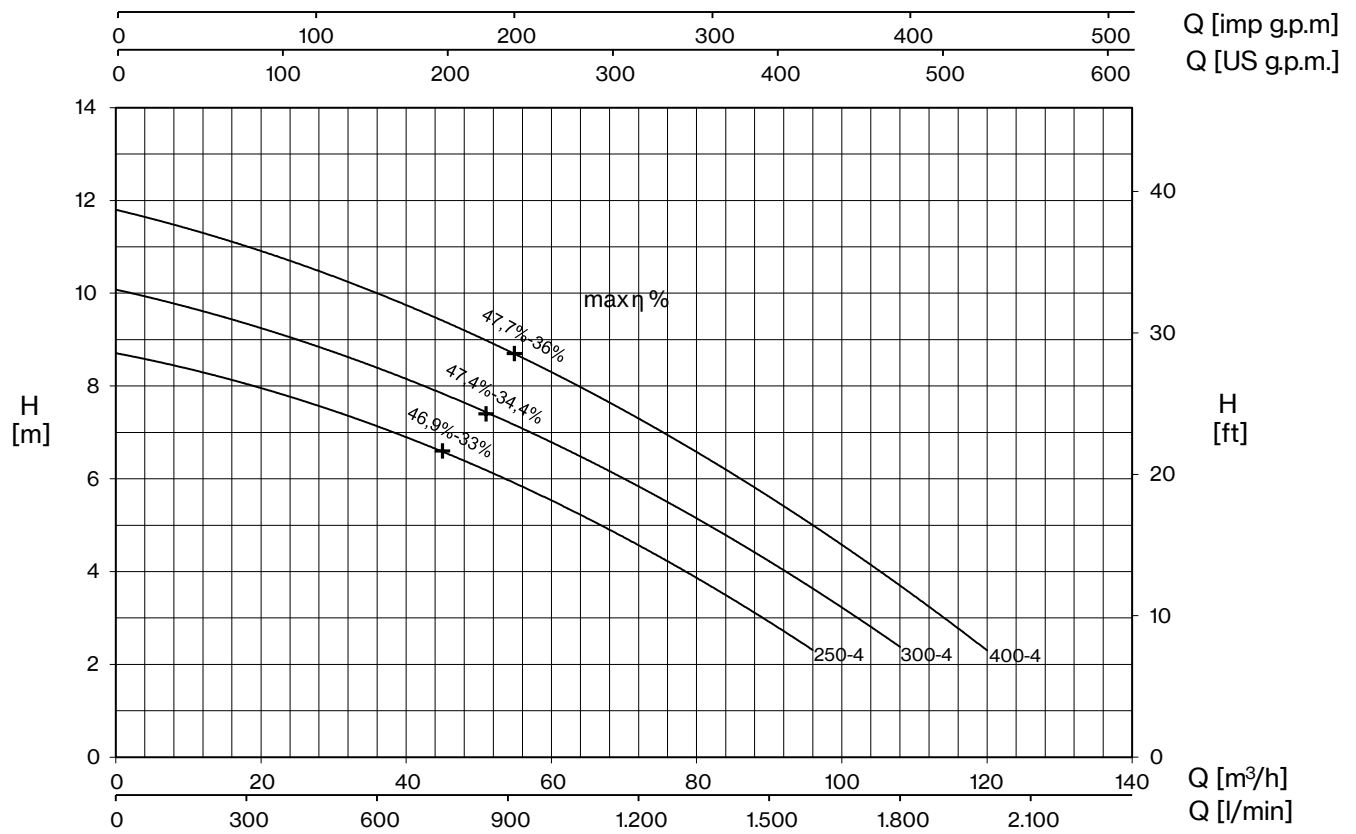

TYPE - 50 Hz	CURRENT			
3~	3- 230V (*)	3- 400V	230/400 V λ / Δ (*)	400/690 V λ / Δ
DVT 250-4	10	5,8	-	-
DVT 300-4	11,8	6,8	-	-
DVT 400-4	15,1	8,7	-	-

+ max η %

max hydraulic efficiency and respective total efficiency

(*) no standard execution

TYPE - 50 Hz	P2		P1	Q (m³/h - l/min)											
				0	12	24	36	48	60	72	84	96	108	120	
3~	HP	kW	kW	H (m)											
				0	200	400	600	800	1000	1200	1400	1600	1800	2000	
DVT 250-4	2,5	1,8	3,3	8,7	8,3	7,8	7,1	6,4	5,5	4,6	3,5	2,3			
DVT 300-4	3	2,2	4,1	10,1	9,6	9,0	8,4	7,7	6,8	5,8	4,8	3,6	2,4		
DVT 400-4	4	3	4,9	11,8	11,3	10,7	10,0	9,2	8,3	7,3	6,2	5,0	3,7	2,3	



DV4

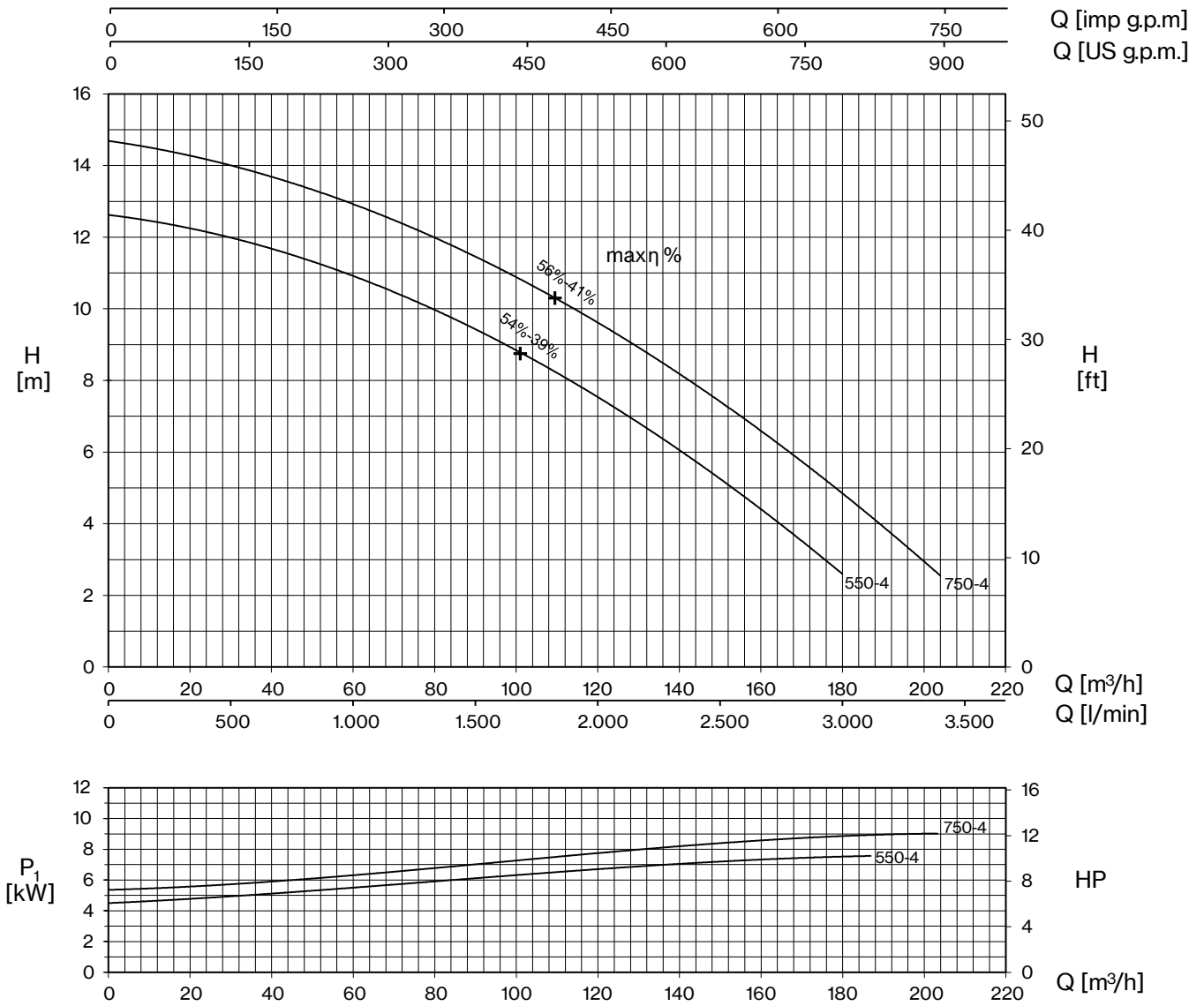

TYPE - 50 Hz	CURRENT			
3~	3~ 230V (*)	3~ 400V	230/400 V λ / Δ (*)	400/690 V λ / Δ
DVT 550-4	-	12,9	22,3	12,9
DVT 750-4	-	15,4	26,6	15,4

+ max η %

max hydraulic efficiency and respective total efficiency

(*) no standard execution

TYPE - 50 Hz	P2			Q (m³/h - l/min)											
				H (m)											
	HP	kW	kW	0	24	48	72	96	120	144	168	180	192	204	
3~				0	400	800	1200	1600	2000	2400	2800	3000	3200	3400	
DVT 550-4	5,5	4	7,5	12,6	12,2	11,4	10,3	9,1	7,6	5,7	3,7	2,6			
DVT 750-4	7,5	5,5	9	14,7	14,2	13,3	12,4	11,2	9,6	7,9	5,9	4,8	3,7	2,6	



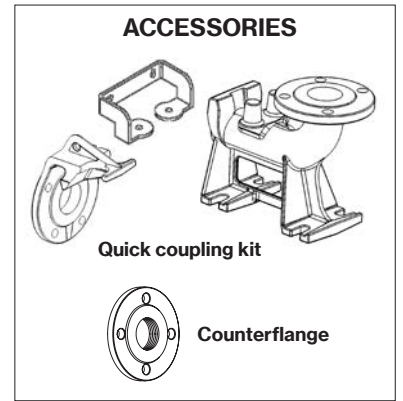
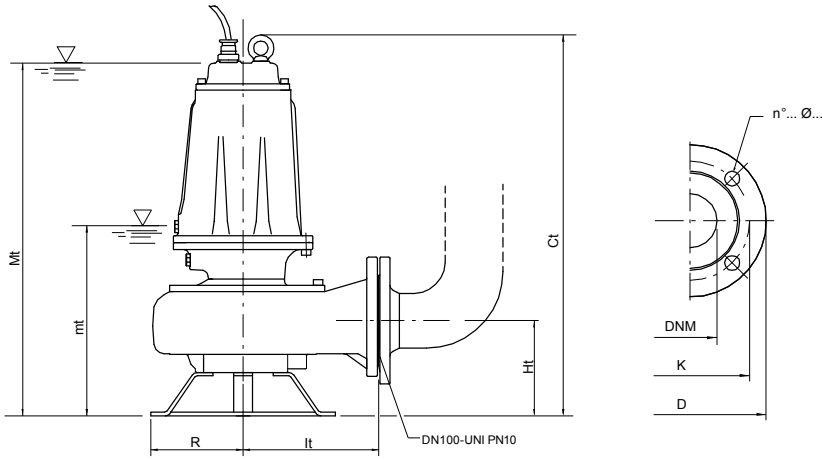

mt: minimum working level
 Mt: minimum submersion level for continuous duty

TYPE	DIMENSIONS (mm)							Kg
	Ct	Ht	R	lt	mt	Mt	DNM	
DVT 250-4	660	165	160	235	300	614	100	69,5
DVT 300-4	660	165	160	235	300	614	100	71
DVT 400-4	660	165	160	235	300	614	100	74,5
DVT 550-4	715	195	180	276	385	695	100	101,5
DVT 750-4	715	195	180	276	385	695	100	106

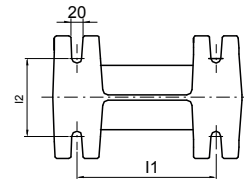
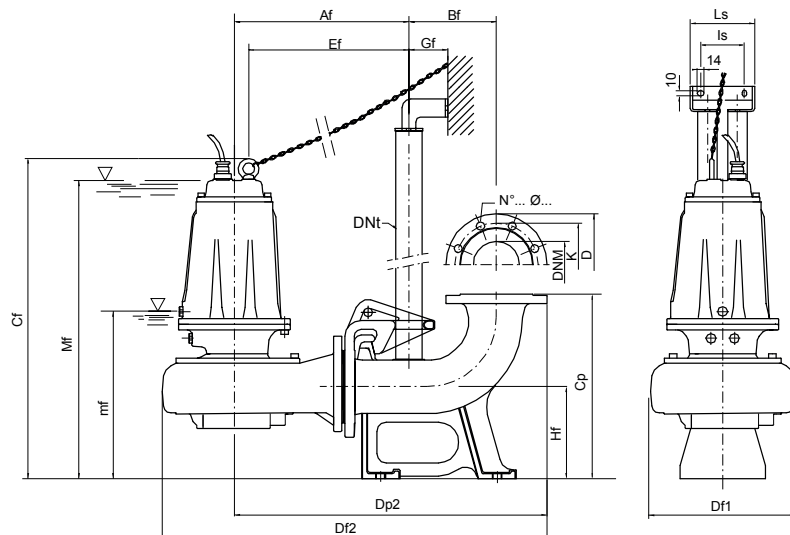

mf: minimum working level
 Mf: minimum submersion level for continuous duty

Flange UNI PN 10 (mm)			
DNM	K	D	n°... Ø...
100	180	220	8... 18...

TYPE	DIMENSIONS (mm)																	
	Af	Bf	Cf	Cp	Df1	Df2	Dp2	Dnt	Ef	Gf	Hf	l1	l2	ls	Ls	mf	Mf	DNM
DVT 250-4/P	378	190	695	400	317	835	678	2"	347	85	200	250	140	130	180	335	650	100
DVT 300-4/P	378	190	695	400	317	835	678	2"	347	85	200	250	140	130	180	335	650	100
DVT 400-4/P	378	190	695	400	317	835	678	2"	347	85	200	250	140	130	180	335	650	100
DVT 550-4/P	419	190	755	400	371	900	719	2"	384	85	200	250	140	130	180	390	700	100
DVT 750-4/P	419	190	755	400	371	900	719	2"	384	85	200	250	140	130	180	390	700	100

TYPE	PROTECTION	1 PUMP CONTROL PANEL		2 PUMPS CONTROL PANEL	
		3- 400V	3- 400V	400/690 V	3- 400V
DVT 250-4	PT 40-50/5.7-9.1		EQSMT 10		EQ2SMT 10
DVT 300-4	PT 40-50/5.7-9.1		EQSMT 10		EQ2SMT 10
DVT 400-4	PT 55-75/8.6-13.5		EQSMT 10		EQ2SMT 10
DVT 550-4	PT 55-75/8.6-13.5		EQSMT 10		EQ2SMT 10
DVT 750-4	PT 100/12.5-16.5		EQSMT 10	QST 10	EQ2SMT 10 Q2ST 10

