

Drainage pumps for charged liquids with set-back Vortex type impeller for civil and industrial applications; specifically designed for very heavy use; available in the mobile or permanent versions with coupling feet.



## Construction features

**Painting** cataphoresis

**Pump body** cast iron



**Impeller** cast iron

**Mechanical seal** double seal with oil barrier: silicon carbide on pump side, ceramic-graphite on motor side

**Motor shaft** stainless steel AISI 304

**Free passage** Ø max 50 mm

**Max submergence** 20 m

**Liquid temperature** 0 - 40 °C

**Cable** H07 RN8F, 10 m

**Bolts** A2 stainless steel

**Foot support** galvanized iron

**Gaskets** NBR rubber

## Motor

**4 Poles induction motor** 3- 220/380V - 60Hz

**Insulation class** F

**Protection degree** IPX8

TYPE	LOTS			
	TRUCK		CONTAINER	
	PALLET (cm)	N° pumps	PALLET (cm)	N° pumps
DVT 250÷4/750-4	85×110×190	8	100×120×190	12

**DV T 550 - 4** ..... poles  
 ..... nominal power HP×100  
 ..... motor **T** 3-  
 ..... pump type

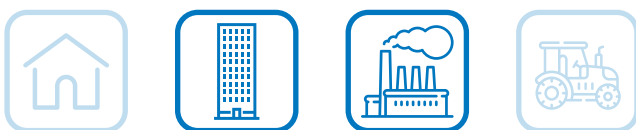

# DV4

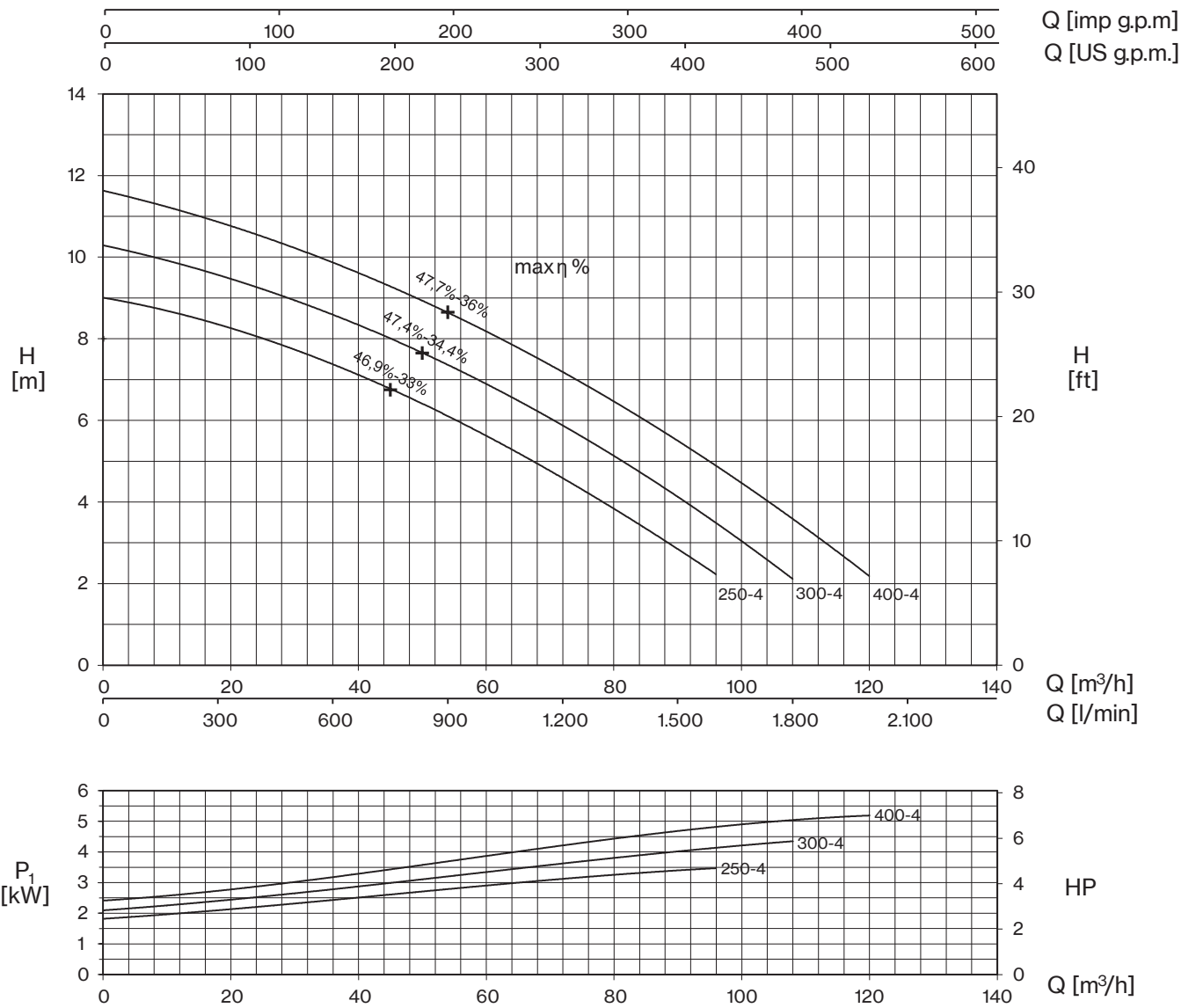

TYPE - 60 Hz	CURRENT		
3~	3- 220V	3- 380V (*)	220/380 V λ / Δ
DVT 250-4	12,70	7,3	-
DVT 300-4	14,70	8,5	-
DVT 400-4	17,70	10,2	-

**+ max η %**

max hydraulic efficiency and respective total efficiency

(\*) no standard execution

TYPE - 60 Hz	P2		P1	Q (m³/h - l/min)											
				0	12	24	36	48	60	72	84	96	108	120	
3~	HP	kW	kW	H (m)											
				0	200	400	600	800	1000	1200	1400	1600	1800	2000	
DVT 250-4	2,5	1,8	4	9	8,6	8,1	7,4	6,5	5,6	4,6	3,5	2,2			
DVT 300-4	3	2,2	4,8	10,3	9,8	9,3	8,6	7,8	6,9	5,8	4,8	3,5	2,1		
DVT 400-4	4	3	5,7	11,6	11,2	10,6	9,8	9	8,2	7,3	6,1	4,8	3,6	2,2	



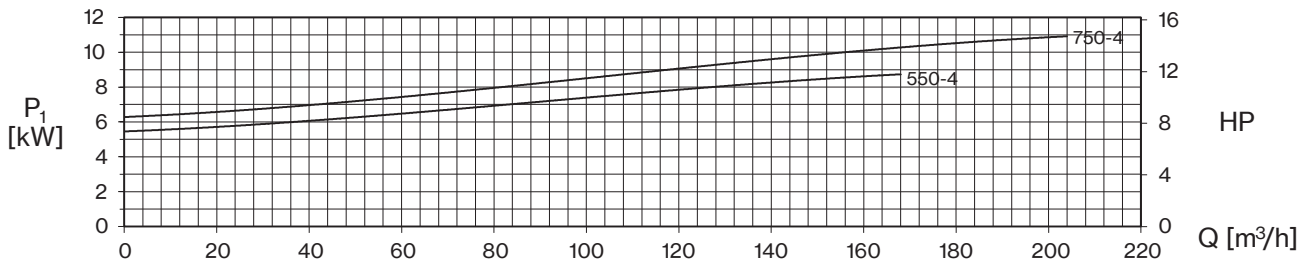
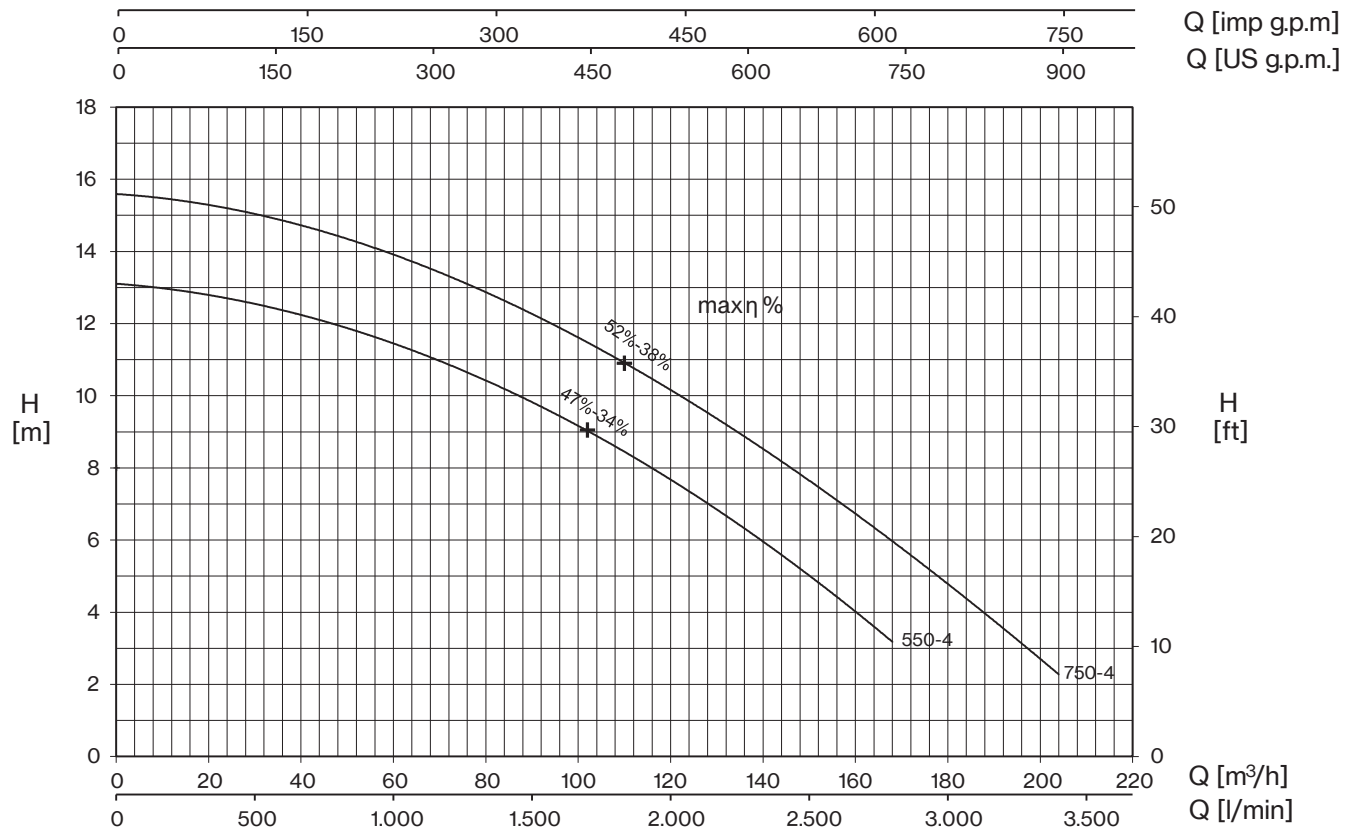

TYPE - 60 Hz	CURRENT		
3~	3- 220V	3- 380V (*)	220/380 V Δ / Δ
DVT 550-4	-	15,8	27,3
DVT 750-4	-	18,6	32,2

+ max η %

max hydraulic efficiency and respective total efficiency

(\*) no standard execution

TYPE - 60 Hz	P2		P1	Q (m³/h - l/min)								
				0	24	48	72	96	120	144	168	204
3~	HP	kW	kW	0	400	800	1200	1600	2000	2400	2800	3400
DVT 550-4	5,5	4	9,0	13,1	12,7	12	10,8	9,4	7,8	5,5	3,2	
DVT 750-4	7,5	5,5	10,7	15,6	15,2	14,4	13,3	11,9	10,2	8,2	5,9	2,3



# DV4

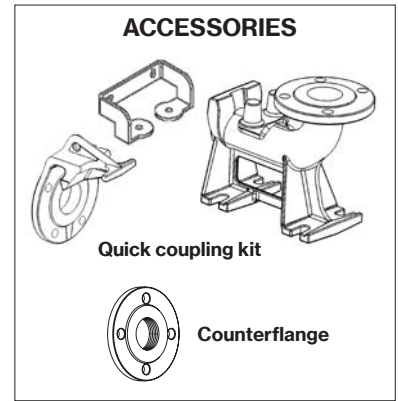
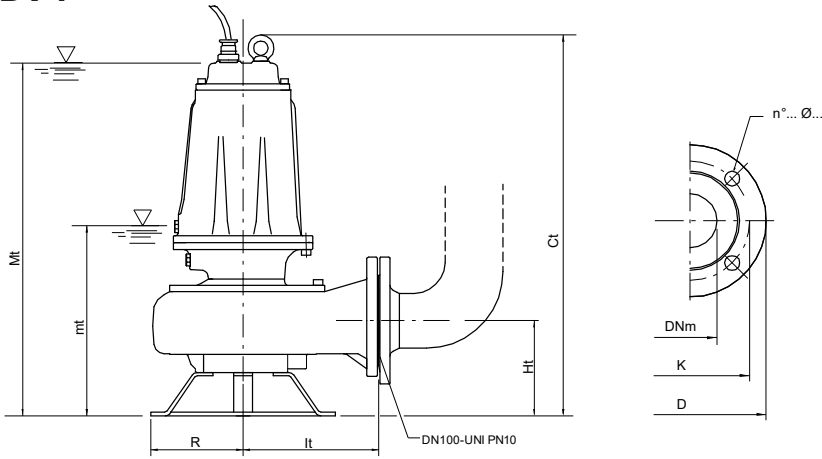

mt: minimum working level  
 Mt: minimum submersion level for continuous duty

TYPE	DIMENSIONS (mm)							Kg
	Ct	Ht	R	It	mt	Mt	DNM	
DVT 250-4	660	165	160	235	300	614	100	70,5
DVT 300-4	660	165	160	235	300	614	100	71,5
DVT 400-4	660	165	160	235	300	614	100	75
DVT 550-4	715	195	180	276	385	695	100	102,5
DVT 750-4	715	195	180	276	385	695	100	109

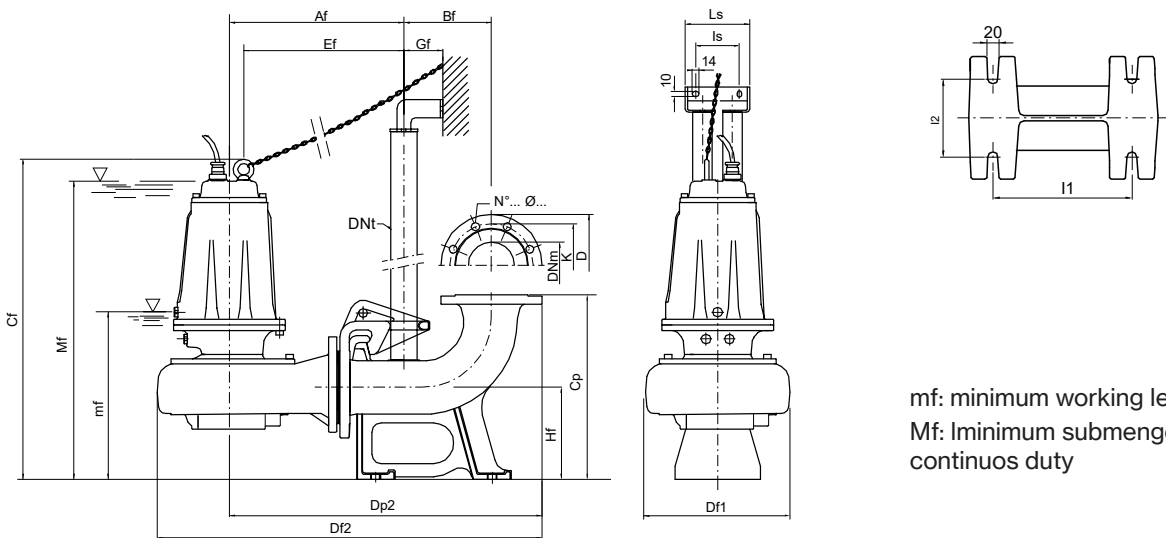

mf: minimum working level  
 Mf: minimum submersion level for continuous duty

TYPE	DIMENSIONS (mm)																		
	Af	Bf	Cf	Cp	Df1	Df2	Dp2	DNT	Ef	Gf	Hf	I1	I2	Is	Ls	mf	Mf	DNM	
DVT 250-4/P	378	190	695	400	317	835	678	2"	347	85	200	250	140	130	180	335	650	100	
DVT 300-4/P	378	190	695	400	317	835	678	2"	347	85	200	250	140	130	180	335	650	100	
DVT 400-4/P	378	190	695	400	317	835	678	2"	347	85	200	250	140	130	180	335	650	100	
DVT 550-4/P	419	190	755	400	371	900	719	2"	384	85	200	250	140	130	180	390	700	100	
DVT 750-4/P	419	190	755	400	371	900	719	2"	384	85	200	250	140	130	180	390	700	100	

Flange UNI PN 10 (mm)			
DNM	K	D	n°... Ø...
100	180	220	8... 18...

