

# ULTRA HS/HX

## Multistage Vertical

Stainless steel multistage vertical pumps. Suitable for clean non-loaded fluids, pressurizing system, irrigation, drinking and glycol water, water treatment, food industry, heating and air conditioning, washing system.

### Construction features

<b>Pump body</b>	HS: cast iron GJL-250 HX: EN 1.4401 / AISI 316
<b>Motor bracket</b>	cast iron
<b>Seal plate housing</b>	HS: EN 1.4301 / AISI 304 HX: EN 1.4401 / AISI 316
<b>Impellers, diffusers, shell</b>	HS: EN 1.4301 / AISI 304 HX: EN 1.4401 / AISI 316
<b>Pump shaft</b>	HS: EN 1.4057 / AISI 431 HX: EN 1.4460 / AISI 329
<b>Mechanical seal</b>	silicon carbide-graphite-EPDM
<b>Intermediate bush</b>	tungsten carbide
<b>Ambient temperature</b>	max 40 °C
<b>Liquid temperature</b>	-15 ÷ +120 °C (Max 85° for domestic use)
<b>Max operating pressure</b>	32 bar (U 35-50) 25 bar (U 75-90)
<b>Pump body gasket</b>	EPDM

### Motor

<b>2 poles induction motor</b>	3- 230/400V - 50Hz P ≤ 4kW, size B14 V1 3- 400/690V - 50Hz P > 4kW, size B5 V1 IE3 efficiency class
<b>Insulation class</b>	F
<b>Protection degree</b>	IP55



ULTRA HS

ULTRA HX

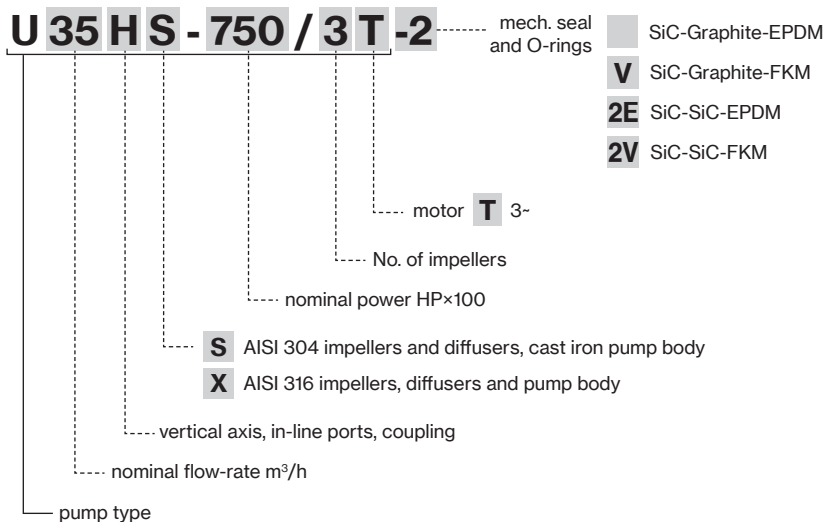

# ULTRA 35-50

TYPE - 50 Hz	P2		Q (l/min - m <sup>3</sup> /h - US gpm)											
			0	417	500	566,7	666,7	700	800	900	1000	1066,7		
			0	25	30	34	40	42	48	54	60	64		
			0	109,9	131,9	149,5	175,9	184,7	211,0	237,4	263,8	281,4		
3-	HP	KW	H (m)											
U 35....-300/1T	3	2,2	24,8	18,6	17,2	15,8	12,7	11,6						
U 35....-550/2-2RT	5,5	4	36,2	29,3	26,3	23,1	17,8	15,7						
U 35....-550/2-1RT	5,5	4	42,8	34,3	31,6	28,8	23,4	21,3						
U 35....-750/2T	7,5	5,5	48,5	39,6	36,9	34,4	29,1	27,2						
U 35....-750/3-2RT	7,5	5,5	60,3	49,0	44,9	40,6	32,7	29,6						
U 35....-1000/3-1RT	10	7,5	67,5	54,1	50,1	46,1	38,0	35,0						
U 35....-1000/3T	10	7,5	72,2	58,2	54,2	50,3	42,4	39,5						
U 35....-1000/4-2RT	10	7,5	85,1	68,6	63,9	58,4	48,8	44,7						
U 35....-1500/4-1RT	15	11	92,8	75,3	70,2	65,2	54,8	50,8						
U 35....-1500/4T	15	11	99,4	81,0	76,3	71,8	62,2	58,5						
U 35....-1500/5-2RT	15	11	109,2	89,5	82,9	76,2	63,5	58,5						
U 35....-1500/5-1RT	15	11	115,1	93,6	87,0	80,6	67,5	62,4						
U 35....-2000/5T	20	15	121,1	99,3	93,1	87,4	74,9	70,0						
U 35....-2000/6-2RT	20	15	133,8	109,6	101,7	93,9	78,7	72,7						
U 35....-2000/6-1RT	20	15	139,7	113,7	105,8	98,3	82,7	76,6						
U 35....-2000/6T	20	15	145,6	119,3	111,9	105,0	90,1	84,2						
U 35....-2000/7-2RT	20	15	157,5	128,3	119,1	110,1	92,3	85,3						
U 35....-2000/7-1RT	20	15	163,3	132,3	123,2	114,4	96,2	89,1						
U 35....-2500/7T	25	18,5	169,2	137,9	129,1	121,0	103,5	96,6						
U 35....-2500/8-2RT	25	18,5	185,5	152,0	142,0	132,5	112,8	105,1						
U 35....-2500/8-1RT	25	18,5	191,9	156,4	146,6	137,4	117,4	109,6						
U 35....-2500/8T	25	18,5	198,4	162,5	153,0	144,6	125,4	117,8						
U 35....-3000/9-2RT	30	22	209,8	171,4	160,2	149,5	127,4	118,7						
U 35....-3000/9-1RT	30	22	216,2	175,8	164,7	154,4	131,9	123,1						
U 35....-3000/9T	30	22	222,7	181,8	171,1	161,5	139,8	131,3						
U 35....-3000/10-2RT	30	22	234,0	190,6	178,1	166,3	141,7	132,1						
U 35....-3000/10-1RT	30	22	240,3	194,9	182,6	171,1	146,1	136,4						
U 35....-4000/10T	40	30	246,8	200,9	188,9	178,2	154,0	144,5						
U 35....-4000/11-2RT	40	30	262,9	218,3	205,1	192,7	166,3	155,8						
U 35....-4000/11-1RT	40	30	269,5	222,9	209,9	197,8	171,2	160,5						
U 35....-4000/11T	40	30	276,2	229,2	216,5	205,3	179,4	169,1						
U 35....-4000/12-2RT	40	30	288,1	240,0	226,0	213,0	184,4	173,3						
U 35....-4000/12-1RT	40	30	294,7	244,8	230,9	218,4	189,7	178,6						
U 35....-4000/12T	40	30	301,4	251,1	237,8	226,0	197,6	188,0						
U 35....-4000/13-2RT	40	30	313,0	260,4	245,3	231,3	200,3	188,3						
U 35....-4000/13-1RT	40	30	319,6	265,2	250,2	236,6	205,6	193,6						
U 35....-4000/13T	40	30	326,3	271,5	257,0	244,2	213,5	202,9						
U 50....-400/1-1RT	4	3	19,6			16,0	14,6	14,0	12,1	9,7	7,0	4,9		
U 50....-550/1T	5,5	4	25,1			20,4	19,0	18,5	16,8	14,8	12,5	10,4		
U 50....-750/2-2RT	7,5	5,5	38,4			33,9	31,5	30,5	27,4	23,7	19,3	16,0		
U 50....-1000/2T	10	7,5	49,0			42,0	39,8	38,8	35,5	31,8	27,5	24,1		
U 50....-1500/3-2RT	15	11	63,0			55,9	52,7	51,4	46,8	41,5	35,1	30,3		
U 50....-1500/3T	15	11	74,2			65,0	62,1	60,9	56,5	51,3	45,5	41,0		
U 50....-2000/4-2RT	20	15	87,5			77,4	73,3	71,6	65,5	58,4	50,1	43,8		
U 50....-2000/4T	20	15	97,5			86,4	82,8	81,3	75,4	68,5	60,8	54,7		
U 50....-2500/5-2RT	25	18,5	112,1			99,9	95,0	92,9	85,5	76,7	66,6	58,8		
U 50....-2500/5T	25	18,5	122,3			109,1	104,7	102,9	95,6	87,1	77,5	70,0		
U 50....-3000/6-2RT	30	22	136,0			120,7	114,9	112,4	103,4	92,9	80,8	71,5		
U 50....-3000/6T	30	22	146,0			129,8	124,5	122,2	113,3	103,0	91,6	82,5		
U 50....-4000/7-2RT	40	30	162,6			146,4	140,1	137,3	127,2	115,2	101,3	90,8		
U 50....-4000/7T	40	30	173,0			155,9	150,1	147,7	137,7	126,0	112,7	102,5		
U 50....-4000/8-2RT	40	30	187,2			168,3	161,1	158,0	146,4	132,7	116,8	104,8		
U 50....-4000/8T	40	30	197,5			177,7	171,1	168,2	156,8	143,4	128,2	116,5		
U 50....-5000/9-2RT	50	37	211,7			190,2	182,2	178,7	165,7	150,3	132,6	119,1		
U 50....-5000/9T	50	37	222,0			199,7	192,2	188,9	176,1	161,0	143,9	130,7		
U 50....-5000/10-2RT	50	37	236,1			211,9	203,0	199,1	184,6	167,5	147,9	132,9		
U 50....-5000/10T	50	37	246,4			221,3	212,9	209,3	195,0	178,1	159,1	144,4		
U 50....-6000/11-2RT	60	45	261,5			235,3	225,7	221,5	205,7	187,0	165,5	149,1		
U 50....-6000/11T	60	45	271,8			244,8	235,7	231,8	216,2	197,7	176,9	160,9		
U 50....-6000/12-2RT	60	45	286,0			257,2	246,7	242,1	224,8	204,5	181,0	163,2		
U 50....-6000/12T	60	45	296,3			266,6	256,7	252,4	235,3	215,2	192,4	174,9		



TYPE - 50 Hz			Q (l/min - m <sup>3</sup> /h - US gpm)								
3-	P2		0	500	666,7	750	833,3	1000	1166,7	1333,3	1466,7
			0	30	40	45	50	60	70	80	88
			0	131,9	175,9	197,9	219,8	263,8	307,8	351,7	386,9
	HP	kW	H (m)								
U 75...-550/1-1RT	5,5	4	21,3	18,2	17,0	16,3	15,5	13,3	10,3	6,8	3,7
U 75...-750/1T	7,5	5,5	30,2	24,8	23,0	22,3	21,7	20,3	18,3	15,4	12,2
U 75...-1000/2-2RT	10	7,5	38,9	37,2	35,8	34,8	33,8	30,5	25,8	20,3	14,6
U 75...-1500/2-1RT	15	11	47,8	44,3	42,6	41,6	40,6	38,0	34,2	29,3	24,0
U 75...-1500/2T	15	11	59,3	51,2	48,0	46,8	45,5	43,2	39,9	35,3	30,8
U 75...-2000/3-2RT	20	15	67,3	63,0	60,6	59,1	57,6	53,4	47,2	39,5	31,4
U 75...-2000/3-1RT	20	15	75,5	69,2	66,3	64,8	63,2	59,5	54,1	46,9	38,7
U 75...-2500/3T	25	18,5	89,6	77,6	72,8	70,9	69,0	65,7	60,7	53,9	47,2
U 75...-2500/4-2RT	25	18,5	95,5	88,6	85,1	83,2	81,1	76,0	68,3	58,5	47,9
U 75...-3000/4-1RT	30	22	103,7	94,7	90,9	88,8	86,7	82,1	75,2	65,9	55,3
U 75...-3000/4T	30	22	111,8	100,8	96,7	94,5	92,4	88,4	82,3	73,3	62,9
U 75...-4000/5-2RT	40	30	125,3	116,2	111,8	109,5	107,0	101,1	92,1	80,4	68,0
U 75...-4000/5-1RT	40	30	133,9	122,7	117,9	115,5	113,0	107,6	99,5	88,4	76,2
U 75...-4000/5T	40	30	142,4	129,2	124,0	121,5	119,0	114,1	106,9	96,3	84,6
U 75...-4000/6-2RT	40	30	153,5	141,6	136,2	133,3	130,3	123,4	112,9	99,0	84,1
U 75...-5000/6-1RT	50	37	162,1	148,2	142,4	139,4	136,4	130,0	120,4	107,1	92,5
U 75...-5000/6T	50	37	170,6	154,7	148,5	145,4	142,3	136,5	127,8	115,0	100,9
U 75...-5000/7-2RT	50	37	181,7	167,0	160,6	157,2	153,6	145,7	133,7	117,7	100,3
U 75...-5000/7-1RT	50	37	190,1	173,5	166,6	163,1	159,5	152,1	141,0	125,5	108,3
U 75...-6000/7T	60	45	199,5	181,1	173,8	170,3	166,7	160,0	149,9	135,1	118,9
U 75...-6000/8-2RT	60	45	210,6	193,5	186,0	182,2	178,1	169,3	156,0	137,9	118,4
U 75...-6000/8-1RT	60	45	219,2	200,0	192,1	188,2	184,1	175,8	163,4	145,9	126,6
U 75...-6000/8T	60	45	227,7	206,5	198,2	194,1	190,1	182,3	170,7	153,8	135,1

TYPE - 50 Hz			Q (l/min - m <sup>3</sup> /h - US gpm)									
3-	P2		0	750	833,3	1000	1166,7	1333,3	1466,7	1666,7	1833,3	1916,7
			0	45	50	60	70	80	88	100	110	115
			0	197,9	219,8	263,8	307,8	351,7	386,9	439,7	483,6	505,6
	HP	kW	H (m)									
U 90...-750/1-1RT	7,5	5,5	26,4	20,5	19,9	18,7	17,3	15,5	13,2	9,5	5,7	3,5
U 90...-1000/1T	10	7,5	35,6	27,0	25,6	23,2	21,9	20,4	18,8	15,7	12,4	10,5
U 90...-1500/2-2RT	15	11	49,6	42,4	41,3	39,0	36,6	33,2	29,4	22,7	15,7	11,7
U 90...-2000/2T	20	15	69,2	56,6	54,5	50,5	47,3	44,3	41,6	36,3	30,5	27,3
U 90...-2500/3-2RT	25	18,5	80,4	70,8	69,1	65,6	62,2	57,7	53,0	44,3	34,9	30,4
U 90...-3000/3T	30	22	92,4	82,6	80,6	76,7	73,2	69,4	65,5	57,8	49,7	45,2
U 90...-4000/4-2RT	40	30	113,1	100,6	98,2	93,5	89,0	83,5	77,5	66,5	54,6	48,5
U 90...-4000/4T	40	30	125,6	113,0	110,4	105,2	100,6	95,7	90,7	80,8	70,2	64,4
U 90...-5000/5-2RT	50	37	144,1	128,4	125,4	119,3	113,7	106,9	99,7	86,1	71,6	64,1
U 90...-5000/5T	50	37	156,6	140,7	137,4	130,9	125,2	119,1	112,8	100,3	87,1	79,8
U 90...-6000/6-2RT	60	45	175,9	157,0	153,4	146,1	139,3	131,4	122,9	107,0	89,8	80,8
U 90...-6000/6T	60	45	188,4	169,5	165,6	157,8	150,9	143,6	136,2	121,3	105,5	96,7



# 35 HS/HX

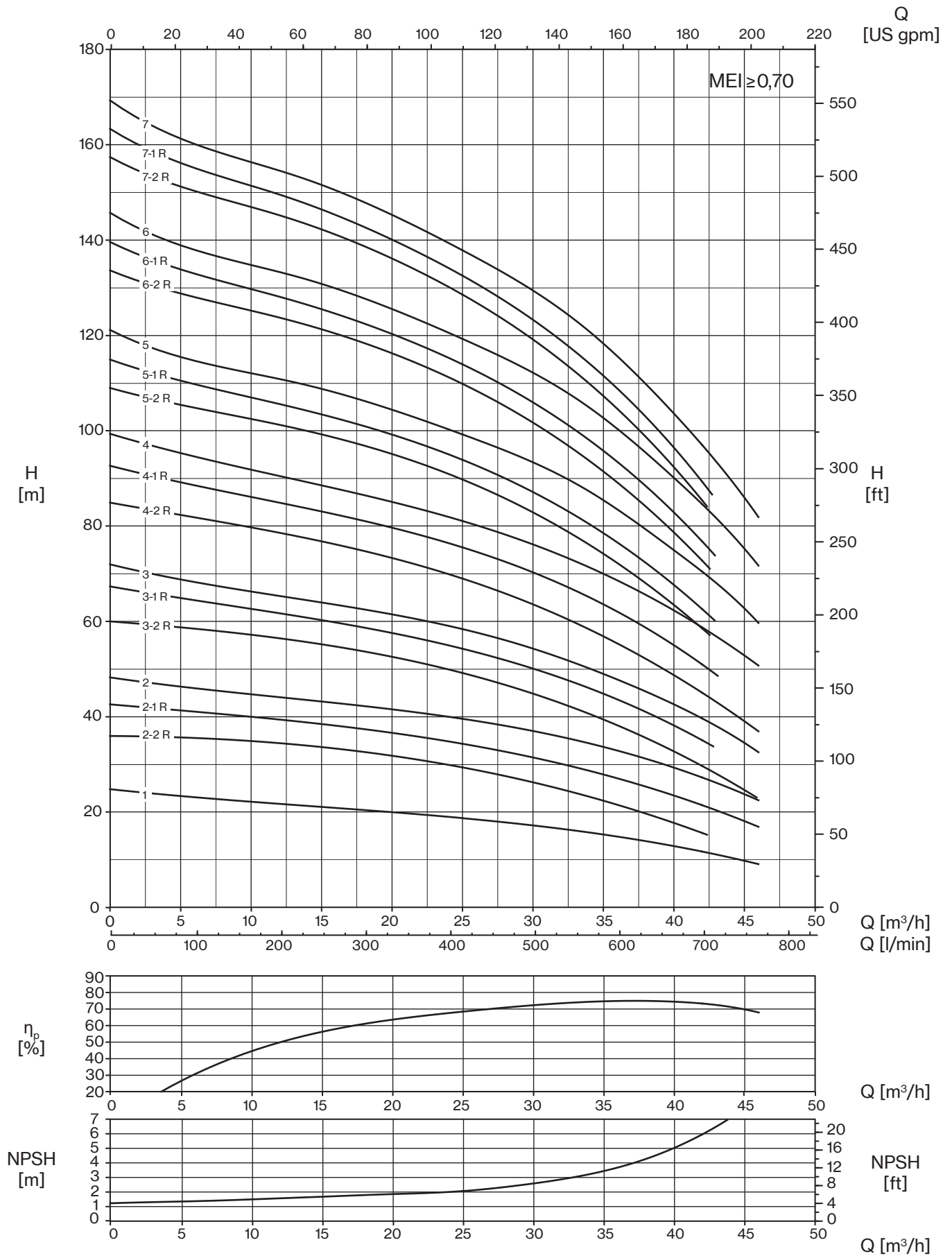

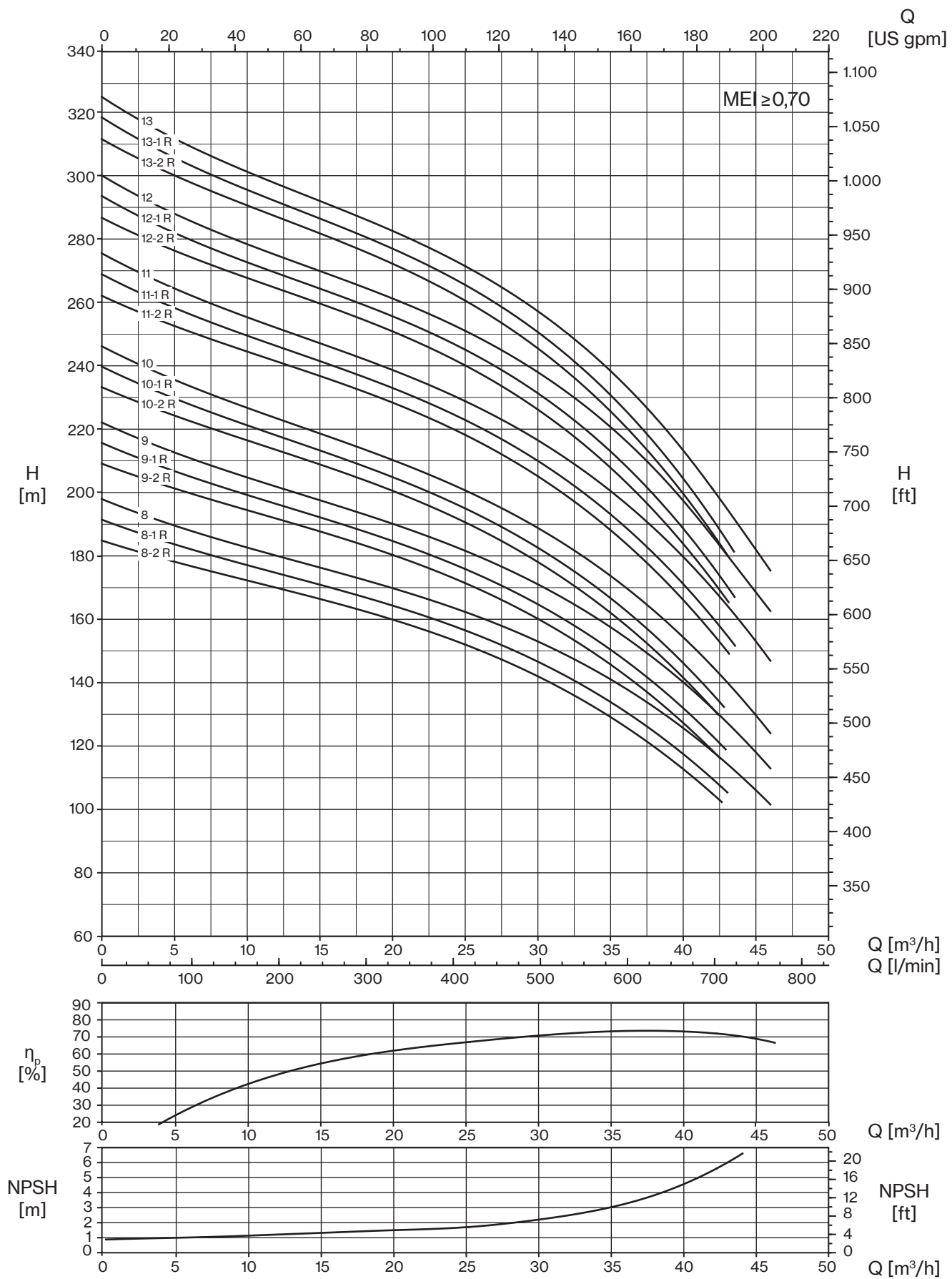

# 50 HS/HX

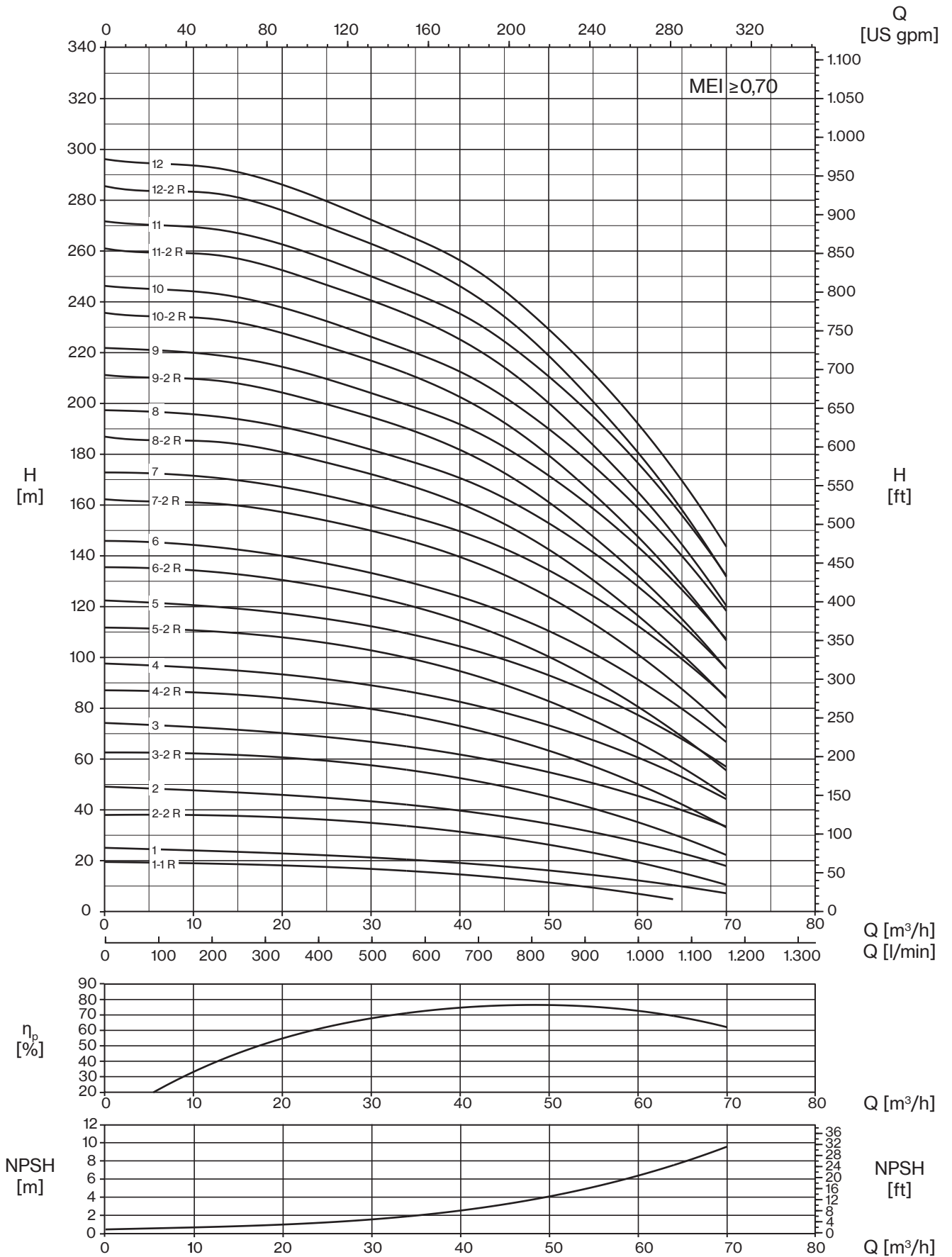

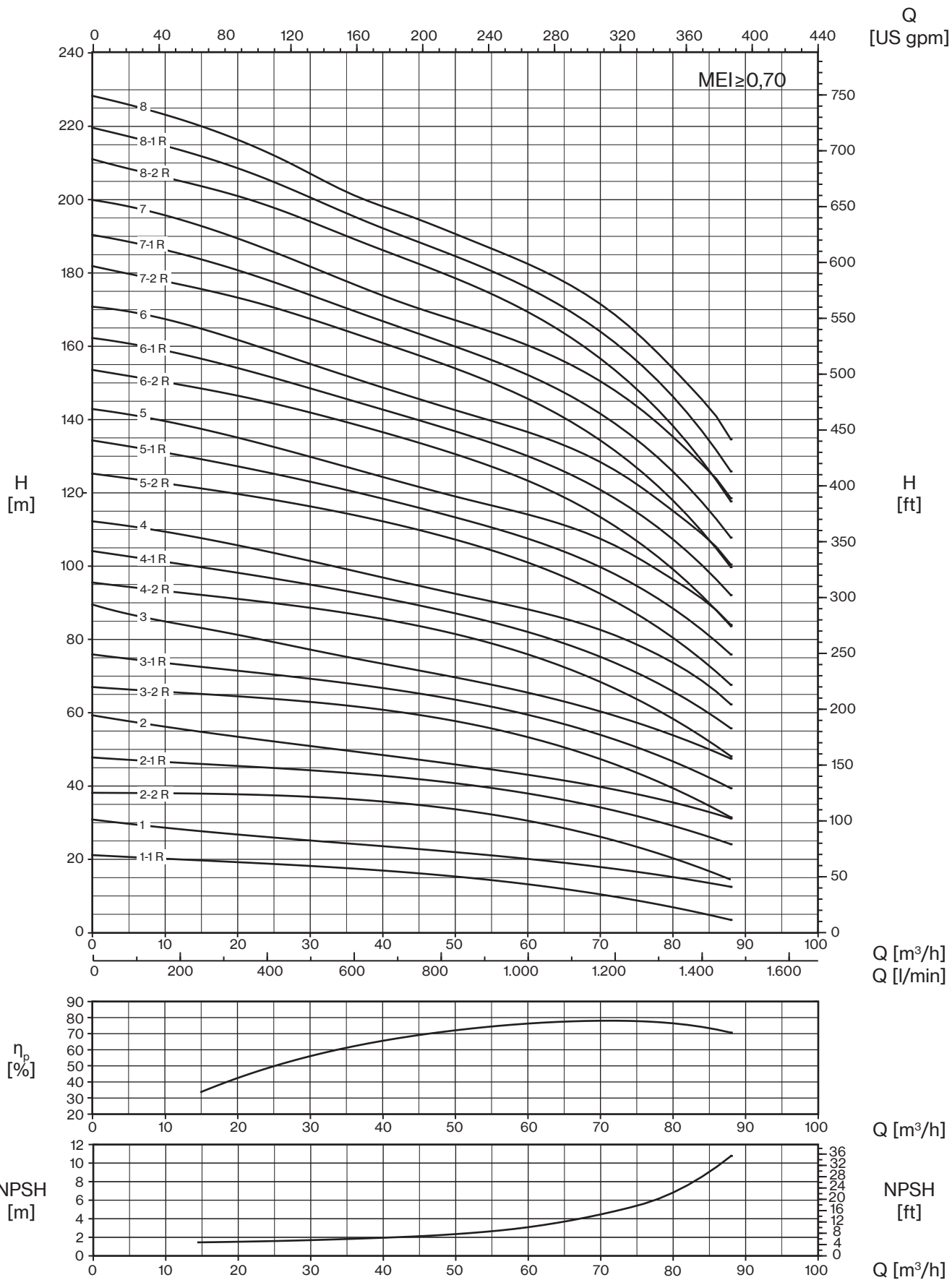

The hydraulic characteristics are guaranteed, according to ISO Standard 9906:2012, grade 3B



# 90 HS/HX

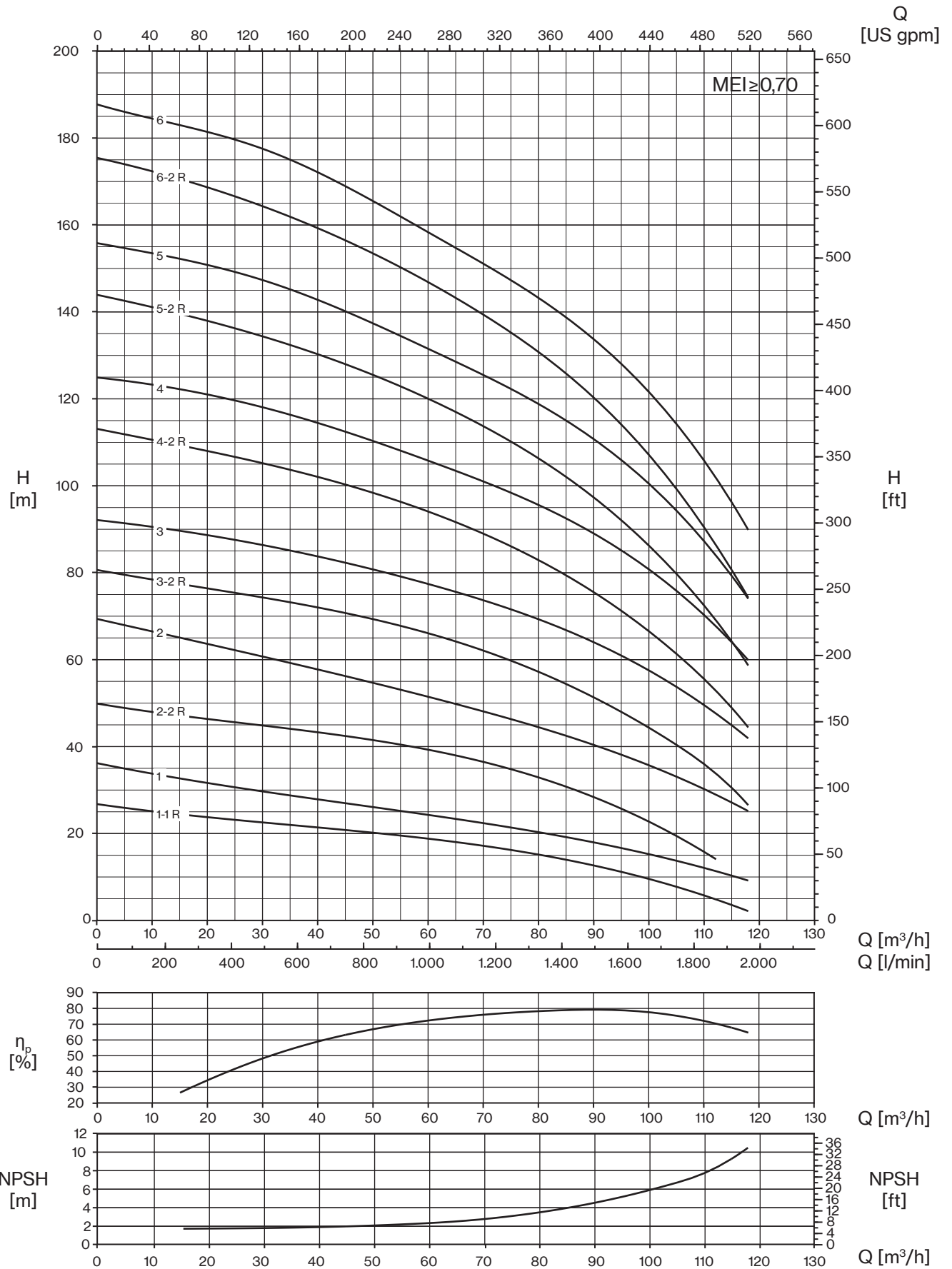

# 35 HS/HX

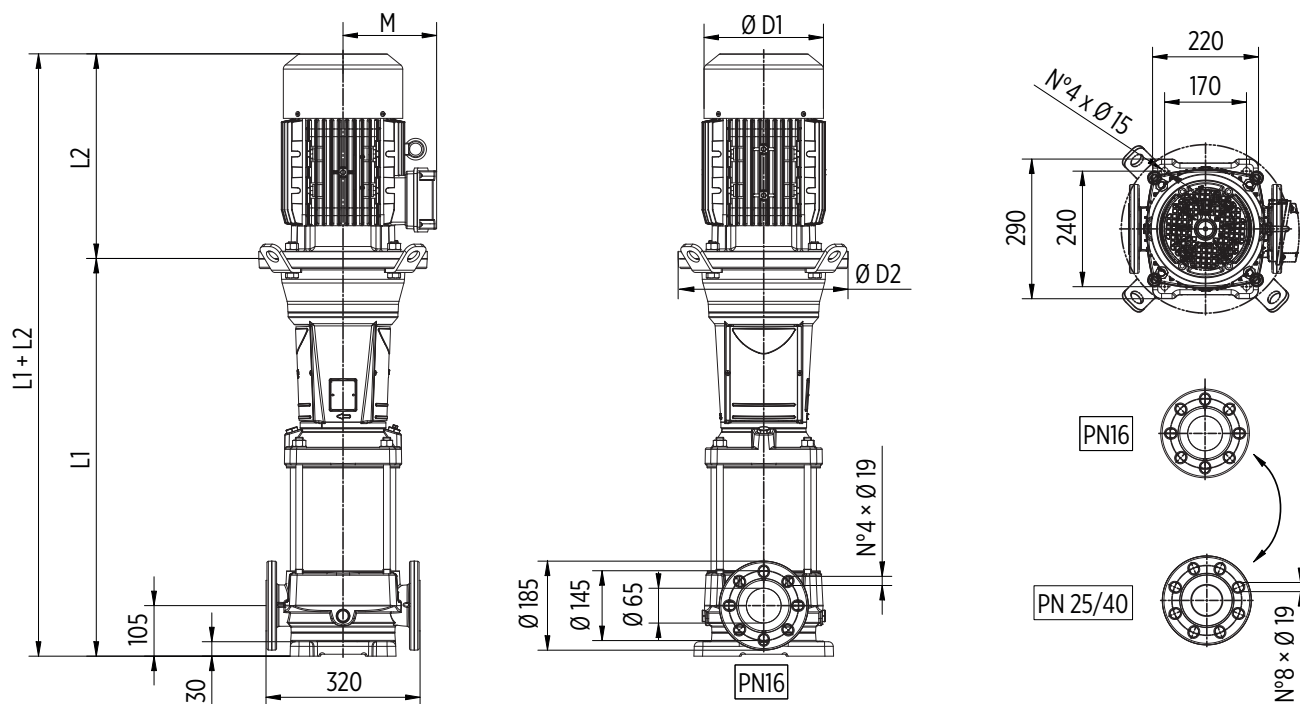

Round flanges on body type PN25/40: the pump is supplied without counterflanges (optional accessories, including bolts and joints)

TYPE	MOTOR		DIMENSIONS (mm)						Kg		
	kW	Dim	L1	L2	M	D1	D2	L1+L2	Pump	Motor	Electric Pump
U 35...-300/1T	2,2	90	431	308	145	177	170	739	48,5	26	74,5
U 35...-550/2-2RT	4	112	513	350	177	220	170	863	52	43	95
U 35...-550/2-1RT	4	112	513	350	177	220	170	863	52	43	95
U 35...-750/2T	5,5	132	724	400	197	256	300	1124	72,5	66	138,5
U 35...-750/3-2RT	5,5	132	806	400	197	256	300	1206	76,5	66	142,5
U 35...-1000/3-1RT	7,5	132	806	400	197	256	300	1206	76,5	73	149,5
U 35...-1000/3T	7,5	132	806	400	197	256	300	1206	76,5	73	149,5
U 35...-1000/4-2RT	7,5	132	888	400	197	256	300	1288	80,5	73	153,5
U 35...-1500/4-1RT	11	160	908	503	255	315	350	1411	84	120	204
U 35...-1500/4T	11	160	908	503	255	315	350	1411	84	120	204
U 35...-1500/5-2RT	11	160	991	503	255	315	350	1494	88	120	208
U 35...-1500/5-1RT	11	160	991	503	255	315	350	1494	88	120	208
U 35...-2000/5T	15	160	991	503	255	315	350	1494	88	132	220
U 35...-2000/6-2RT	15	160	1073	503	255	315	350	1576	92	132	224
U 35...-2000/6-1RT	15	160	1073	503	255	315	350	1576	92	132	224
U 35...-2000/6T	15	160	1073	503	255	315	350	1576	92	132	224
U 35...-2000/7-2RT	15	160	1155	503	255	315	350	1658	96	132	228
U 35...-2000/7-1RT	15	160	1155	503	255	315	350	1658	96	132	228
U 35...-2500/7T	18,5	160	1155	598	252	315	350	1753	96	150	246
U 35...-2500/8-2RT	18,5	160	1237	598	252	315	350	1835	100	150	250
U 35...-2500/8-1RT	18,5	160	1237	598	252	315	350	1835	100	150	250
U 35...-2500/8T	18,5	160	1237	598	252	315	350	1835	100	150	250
U 35...-3000/9-2RT	22	180	1319	620	270	360	350	1939	103,5	205	308,5
U 35...-3000/9-1RT	22	180	1319	620	270	360	350	1939	103,5	205	308,5
U 35...-3000/9T	22	180	1319	620	270	360	350	1939	103,5	205	308,5
U 35...-3000/10-2RT	22	180	1401	620	270	360	350	2021	107,5	205	312,5
U 35...-3000/10-1RT	22	180	1401	620	270	360	350	2021	107,5	205	312,5
U 35...-4000/10T	30	200	1406	661	303	400	400	2067	111	250	361
U 35...-4000/11-2RT	30	200	1488	661	303	400	400	2149	115	250	365
U 35...-4000/11-1RT	30	200	1488	661	303	400	400	2149	115	250	365
U 35...-4000/11T	30	200	1488	661	303	400	400	2149	115	250	365
U 35...-4000/12-2RT	30	200	1570	661	303	400	400	2231	119	250	369
U 35...-4000/12-1RT	30	200	1570	661	303	400	400	2231	119	250	369
U 35...-4000/12T	30	200	1570	661	303	400	400	2231	119	250	369
U 35...-4000/13-2RT	30	200	1652	661	303	400	400	2313	122,5	250	372,5
U 35...-4000/13-1RT	30	200	1652	661	303	400	400	2313	122,5	250	372,5
U 35...-4000/13T	30	200	1652	661	303	400	400	2313	122,5	250	372,5



## 50 HS/HX

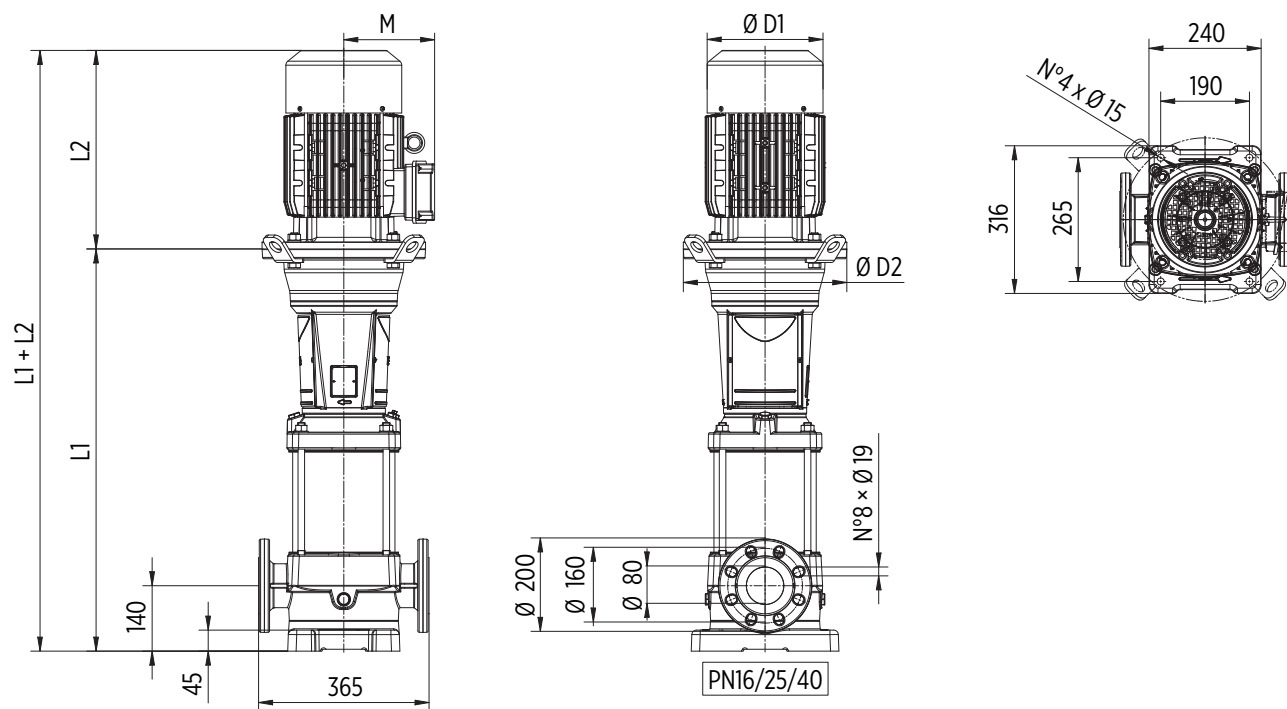

Round flanges on body type PN25/40: the pump is supplied without counterflanges (optional accessories, including bolts and joints)

TYPE	MOTOR		DIMENSIONS (mm)						Kg		
	kW	Dim	L1	L2	M	D1	D2	L1+L2	Pump	Motor	Electric Pump
U 50...-400/1-1RT	3	100	466	333	157	205	170	799	54	35	89
U 50...-550/1T	4	112	466	350	177	220	170	816	54	43	97
U 50...-750/2-2RT	5,5	132	759	400	197	256	300	1159	78,5	66	144,5
U 50...-1000/2T	7,5	132	759	400	197	256	300	1159	78,5	73	151,5
U 50...-1500/3-2RT	11	160	861	503	255	315	350	1364	85,5	120	205,5
U 50...-1500/3T	11	160	861	503	255	315	350	1364	85,5	120	205,5
U 50...-2000/4-2RT	15	160	943	503	255	315	350	1446	89,5	132	221,5
U 50...-2000/4T	15	160	943	503	255	315	350	1446	89,5	132	221,5
U 50...-2500/5-2RT	18,5	160	1026	598	252	315	350	1624	93,5	150	243,5
U 50...-2500/5T	18,5	160	1026	598	252	315	350	1624	93,5	150	243,5
U 50...-3000/6-2RT	22	180	1108	620	270	360	350	1728	97,5	205	302,5
U 50...-3000/6T	22	180	1108	620	270	360	350	1728	97,5	205	302,5
U 50...-4000/7-2RT	30	200	1195	661	303	400	400	1856	104,5	250	354,5
U 50...-4000/7T	30	200	1195	661	303	400	400	1856	104,5	250	354,5
U 50...-4000/8-2RT	30	200	1277	661	303	400	400	1938	108,5	250	358,5
U 50...-4000/8T	30	200	1277	661	303	400	400	1938	108,5	250	358,5
U 50...-5000/9-2RT	37	200	1359	661	303	400	400	2020	112,5	270	382,5
U 50...-5000/9T	37	200	1359	661	303	400	400	2020	112,5	270	382,5
U 50...-5000/10-2RT	37	200	1441	661	303	400	400	2102	116,5	270	386,5
U 50...-5000/10T	37	200	1441	661	303	400	400	2102	116,5	270	386,5
U 50...-6000/11-2RT	45	225	1523	710	312	450	450	2233	122,5	315	437,5
U 50...-6000/11T	45	225	1523	710	312	450	450	2233	122,5	315	437,5
U 50...-6000/12-2RT	45	225	1605	710	312	450	450	2315	126,5	315	441,5
U 50...-6000/12T	45	225	1605	710	312	450	450	2315	126,5	315	441,5



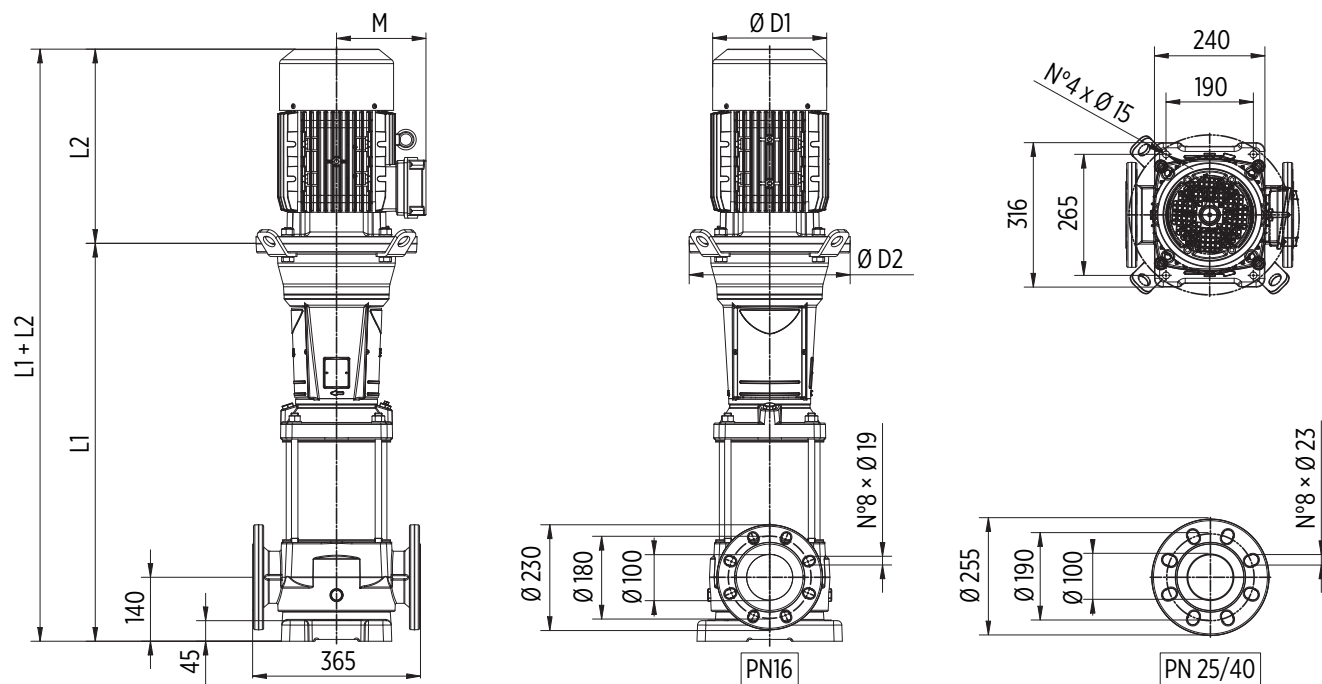

Round flanges on body type PN25/40: the pump is supplied without counterflanges (optional accessories, including bolts and joints)

TYPE	MOTOR		DIMENSIONS (mm)						Kg		
	kW	Dim	L1	L2	M	D1	D2	L1+L2	Pump	Motor	Electric Pump
U 75...-550/1-1RT	4	112	526	350	177	220	170	876	60	43	103
U 75...-750/1T	5,5	132	737	400	197	256	300	1137	80,5	66	146,5
U 75...-1000/2-2RT	7,5	132	829	400	197	256	300	1229	85	73	158
U 75...-1500/2-1RT	11	160	849	503	255	315	350	1352	88,5	120	208,5
U 75...-1500/2T	11	160	849	503	255	315	350	1352	88,5	120	208,5
U 75...-2000/3-2RT	15	160	941	503	255	315	350	1444	93	132	225
U 75...-2000/3-1RT	15	160	941	503	255	315	350	1444	93	132	225
U 75...-2500/3T	18,5	160	941	598	252	315	350	1539	93	150	243
U 75...-2500/4-2RT	18,5	160	1033	598	252	315	350	1631	97,5	150	247,5
U 75...-3000/4-1RT	22	180	1033	620	270	360	350	1653	97	205	302
U 75...-3000/4T	22	180	1033	620	270	360	350	1653	97	205	302
U 75...-4000/5-2RT	30	200	1131	661	303	400	400	1792	105	250	355
U 75...-4000/5-1RT	30	200	1131	661	303	400	400	1792	105	250	355
U 75...-4000/5T	30	200	1131	661	303	400	400	1792	105	250	355
U 75...-4000/6-2RT	30	200	1223	661	303	400	400	1884	109,5	250	359,5
U 75...-5000/6-1RT	37	200	1223	661	303	400	400	1884	109,5	270	379,5
U 75...-5000/6T	37	200	1223	661	303	400	400	1884	109,5	270	379,5
U 75...-5000/7-2RT	37	200	1315	661	303	400	400	1976	113,5	270	383,5
U 75...-5000/7-1RT	37	200	1315	661	303	400	400	1976	113,5	270	383,5
U 75...-6000/7T	45	225	1315	710	312	450	450	2025	116	315	431
U 75...-6000/8-2RT	45	225	1407	710	312	450	450	2117	120,5	315	435,5
U 75...-6000/8-1RT	45	225	1407	710	312	450	450	2117	120,5	315	435,5
U 75...-6000/8T	45	225	1407	710	312	450	450	2117	120,5	315	435,5

# 90 HS/HX

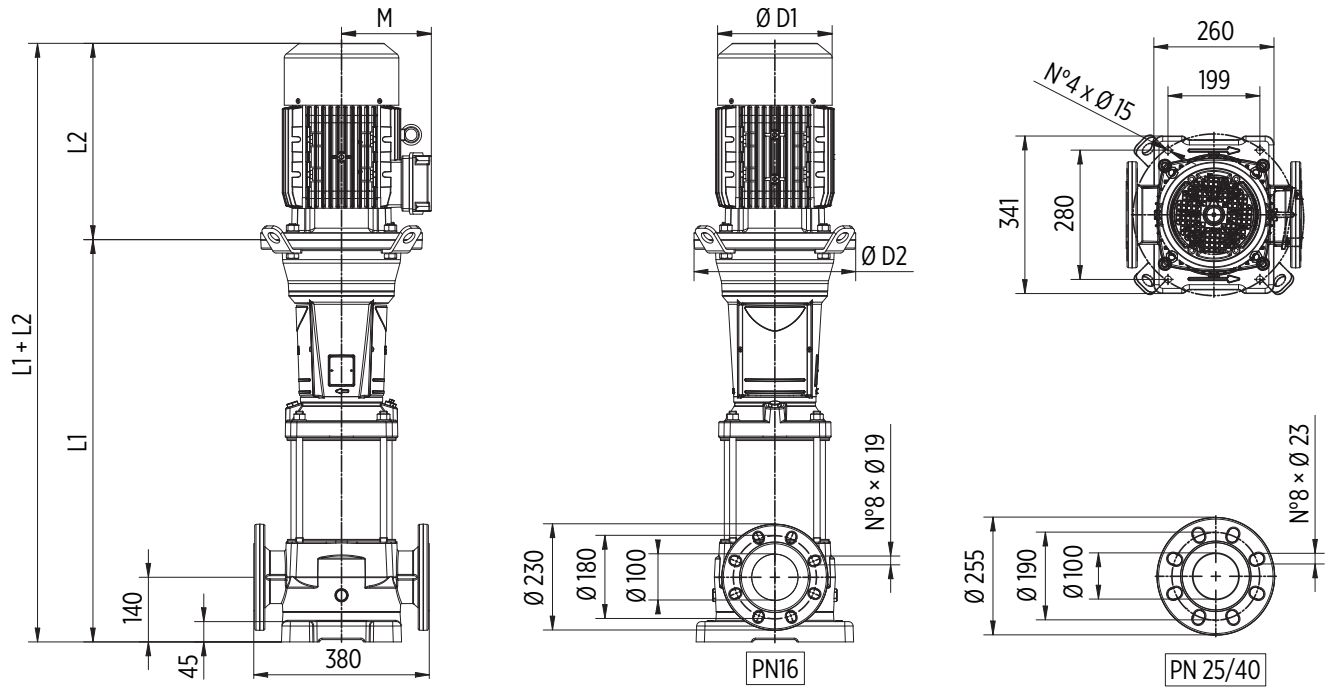



Round flanges on body type PN25/40: the pump is supplied without counterflanges (optional accessories, including bolts and joints)

TYPE	MOTOR		DIMENSIONS (mm)						Kg		
	kW	Dim	L1	L2	M	D1	D2	L1+L2	Pump	Motor	Electric Pump
U 90...-750/1-1RT	5,5	132	737	400	197	256	300	1137	82	66	148
U 90...-1000/1T	7,5	132	737	400	197	256	300	1137	82	73	155
U 90...-1500/2-2RT	11	160	849	503	255	315	350	1352	89	120	209
U 90...-2000/2T	15	160	849	503	255	315	350	1352	89	132	221
U 90...-2500/3-2RT	18,5	160	941	598	252	315	350	1539	93	150	243
U 90...-3000/3T	22	180	941	620	270	360	350	1561	92,5	205	297,5
U 90...-4000/4-2RT	30	200	1038	661	303	400	400	1699	99,5	250	349,5
U 90...-4000/4T	30	200	1038	661	303	400	400	1699	99,5	250	349,5
U 90...-5000/5-2RT	37	200	1131	661	303	400	400	1792	103	270	373
U 90...-5000/5T	37	200	1131	661	303	400	400	1792	103	270	373
U 90...-6000/6-2RT	45	225	1223	710	312	450	450	1933	109	315	424
U 90...-6000/6T	45	225	1223	710	312	450	450	1933	109	315	424



# ULTRA HS-HX Serie-Mechanical seal and bearings

CARTRIDGE MECHANICAL SEAL	PUMP MODEL	SHAFT Ø		STANDARD MATERIAL	OPTIONAL		
					V	2	2V
	U18-100/1T, U18-200/2T, U18-300/3T, U18-400/4T, U18-550/5T, U18-750/6T, U18-750/7T, U18-1000/8T, U18-1000/9T, U18-1500/10T, U18-1500/11T, U18-1500/12T, U18-1500/13T, U18-1500/14T, U18-2000/15T, U18-2000/16T, U18-2000/17T, U22-150/1T, U22-300/2T, U22-400/3T, U22-550/4T, U22-750/5T, U22-1000/6T, U22-1000/7T, U22-1500/8T, U22-1500/9T, U22-1500/10T, U22-2000/11T, U22-2000/12T, U22-2000/13T	16mm	<b>Rotating face</b> <b>Stationary face</b> <b>Elastomer</b>	SiC Graphite EPDM	SiC Graphite FKM	SiC SiC EPDM	SiC SiC FKM
	U35-300/1T, U35-550/2-2RT, U35-550/2-1RT, U35-750/2T, U35-750/3-2RT, U35-1000/3-1RT, U35-1000/3T, U35-1000/4-2RT, U35-1500/4-1RT, U35-1500/4T, U35-1500/5-2RT, U35-1500/5-1RT, U35-2000/5T, U35-2000/6-2RT, U35-2000/6-1RT, U35-2000/6T, U35-2000/7-2RT, U35-2000/7-1RT, U35-2500/7T, U35-2500/8-2RT, U35-2500/8-1RT, U35-2500/8T, U35-3000/9-2RT, U35-3000/9-1RT, U35-3000/9T, U35-3000/10-2RT, U35-3000/10-1RT, U35-4000/10T, U35-4000/11-2RT, U35-4000/11-1RT, U35-4000/11T, U35-4000/12-2RT, U35-4000/12-1RT, U35-4000/12T, U35-4000/13-2RT, U35-4000/13-1RT, U35-4000/13T, U50-400/1-1RT, U50-550/1T, U50-750/2-2RT, U50-1000/2T, U50-1500/3-2RT, U50-1500/3T, U50-2000/4-2RT, U50-2000/4T, U50-2500/5-2RT, U50-2500/5T, U50-3000/6-2RT, U50-3000/6T, U50-4000/7-2RT, U50-4000/7T, U50-4000/8-2RT, U50-4000/8T, U50-5000/9-2RT, U50-5000/9T, U50-5000/10-2RT, U50-5000/10T, U50-6000/11-2RT, U50-6000/11T, U50-6000/12-2RT, U50-6000/12T, U75-550/1-1RT, U75-750/1T, U75-1000/2-2RT, U75-1500/2-1RT, U75-1500/2T, U75-2000/3-2RT, U75-2000/3-1RT, U75-2500/3T, U75-2500/4-2RT, U75-3000/4-1RT, U75-3000/4T, U75-4000/5-2RT, U75-4000/5-1RT, U75-4000/5T, U75-4000/6-2RT, U75-5000/6-1RT, U75-5000/6T, U75-5000/7-2RT, U75-5000/7-1RT, U75-6000/7T, U75-6000/8-2RT, U75-6000/8-1RT, U75-6000/8T, U90-750/1-1RT, U90-1000/1T, U90-1500/2-2RT, U90-2000/2T, U90-2500/3-2RT, U90-3000/3T, U90-4000/4-2RT, U90-4000/4T, U90-5000/5-2RT, U90-5000/5T, U90-6000/6-2RT, U90-6000/6T	22mm / Balanced seal	<b>Rotating face</b> <b>Stationary face</b> <b>Elastomer</b>	SiC Graphite EPDM	SiC Graphite FKM	SiC SiC EPDM	SiC SiC FKM

BEARINGS	PUMP MODEL	PUMP THRUST BEARING		MOTOR BEARING	
	U18-100/1T, U22-150/1T	-	-	6204-ZZ C3	6204-ZZ C3
	U18-200/2T, U18-300/3T, U22-300/2T, U35-300/1T	-	-	6205-ZZ C3	6205-ZZ C3
	U18-400/4T, U18-550/5T, U22-400/3T, U22-550/4T, U35-550/2-2RT, U35-550/2-1RT, U50-400/1-1RT, U50-550/1T, U75-550/1-1RT	-	-	6206-ZZ C3	6206-ZZ C3
	U18-750/6T, U18-750/7T, U18-1000/8T, U18-1000/9T, U22-750/5T, U22-1000/6T, U22-1000/7T, U35-750/2T, U35-750/3-2RT, U35-1000/3-1RT, U35-1000/3T, U35-1000/4-2RT, U50-750/2-2RT, U50-1000/2T, U75-750/1T, U75-1000/2-2RT, U90-750/1-1RT, U90-1000/1T	6212 ZZ	-	6208-ZZ C3	6208-ZZ C3
	U18-1500/10T, U18-1500/11T, U18-1500/12T, U18-1500/13T, U18-1500/14T, U18-2000/15T, U18-2000/16T, U18-2000/17T, U22-1500/8T, U22-1500/9T, U22-1500/10T, U22-2000/11T, U22-2000/12T, U22-2000/13T, U22-2000/14T, U22-2500/15T, U22-2500/16T, U22-2500/17T, U35-1500/4-1RT, U35-1500/4T, U35-1500/5-2RT, U35-1500/5-1RT, U50-1500/3-2RT, U50-1500/3T, U75-1500/2-1RT, U75-1500/2T, U90-1500/2-2RT	6212 ZZ	-	6309-ZZ C3	6309-ZZ C3
	U35-2000/5T, U35-2000/6-2RT, U35-2000/6-1RT, U35-2000/6T, U35-2000/7-2RT, U35-2000/7-1RT, U35-2500/7T, U35-2500/8-2RT, U35-2500/8-1RT, U35-2500/8T, U50-2000/4-2RT, U50-2000/4T, U50-2500/5-2RT, U50-2500/5T, U75-2000/3-2RT, U75-2000/3-1RT, U75-2500/3T, U75-2500/4-2RT, U90-2000/2T, U90-2500/3-2RT	6212 ZZ	7212 BEP	6311-ZZ C3	6311-ZZ C3
	U35-3000/9-2RT, U35-3000/9-1RT, U35-3000/9T, U35-3000/10-2RT, U35-3000/10-1RT, U50-3000/6-2RT, U50-3000/6T, U75-3000/4-1RT, U75-3000/4T, U90-3000/3T	6214 ZZ	7214 BEP	6312-ZZ C3	6312-ZZ C3
	U35-4000/10T, U35-4000/11-2RT, U35-4000/11-1RT, U35-4000/11T, U35-4000/12-2RT, U35-4000/12-1RT, U35-4000/12T, U35-4000/13-2RT, U35-4000/13-1RT, U35-4000/13T, U50-4000/7-2RT, U50-4000/7T, U50-4000/8-2RT, U50-4000/8T, U50-5000/9-2RT, U50-5000/9T, U50-5000/10-2RT, U50-5000/10T, U75-4000/5-2RT, U75-4000/5-1RT, U75-4000/5T, U75-4000/6-2RT, U75-5000/6-1RT, U75-5000/6T, U75-5000/7-2RT, U75-5000/7-1RT, U90-4000/4-2RT, U90-4000/4T, U90-5000/5-2RT, U90-5000/5T	6214 ZZ	7214 BEP	6313-ZZ C3	6313-ZZ C3
U50-6000/11-2RT, U50-6000/11T, U50-6000/12-2RT, U50-6000/12T, U75-6000/7T, U75-6000/8-2RT, U75-6000/8-1RT, U75-6000/8T, U90-6000/6-2RT, U90-6000/6T			6313-ZZ C3	6313-ZZ C3	



# ULTRA V/L/H + VSD

Vertical booster pump with variable speed drive

## ULTRA V



EPIC / EPIC-A

IPFC

## ULTRA L



EPIC / EPIC-A

IPFC

## ULTRA H



IPFC

### DESCRIPTION

Vertical pump of ULTRA series provided with variable speed drive EPIC, EPIC-A or IPFC. This booster pump assures a desired pressure regardless of changes on flow demand making it suitable for low or missing pressure in residential systems and industrial applications. It is required the installation of a membrane tank downstream the system.

### FEATURES

- EPIC, EPIC-A or IPFC variable speed drive
- Three-phase vertical pump of ULTRA series
- Pressure sensor wired to the vsd
- Cable with plug for EPIC vsd only

### FUNCTIONING

If the pressure in the network drops the pump will start and gradually speeds up to provide with the set pressure. When the water demand decreases, the pressure will rise causing the pump speed to slow down and eventually to stop the pump if demand ceases. The pump will remain on standby waiting to start at the next water demand.

### SELECTION

The next table shows the vertical ULTRA pump models available for the assembly with EPIC, EPIC-A or IPFC. For pumps longer than 1.4m, IPFC is not assembled onto the motor fan cover but is supplied with a wall-mounting kit. Consult the catalog at the ULTRA series for pump specifics and characteristic curves.

**U3SL /A 100/5 T -304 3×400-50**

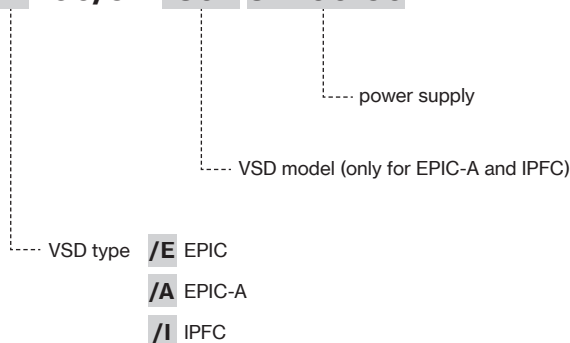

		3- PUMP						VSD TYPE							
TYPE		VERSION						Power supply							
		V	SV	L	SL/SLX	LG	SLG/SLGX	1-230V		3-400V					
U 3	100/5T	■	■	■	■	-	-	EPIC	IPFC 109	EPIC-A 304	IPFC 306				
	120/6T	■	■	■	■	-	-								
	150/7T	■	■	■	■	-	-								
	180/8T	■	■	■	■	-	-								
	200/9T	■	■	■	■	-	-								
	250/10T	■	■	■	■	-	-		-	IPFC 114	EPIC-A 306				
	280/11T	■	■	■	■	-	-								
	300/12T	■	■	■	■	-	-								
	350/14T	-	-	-	-	-	■								
	380/16T	-	-	-	-	-	■								
	400/18T	-	-	-	-	-	■								
450/20T	-	-	-	-	-	■	-	-	EPIC-A 309	IPFC 309					
U 5	120/4T	■	■	■	■	-	-	EPIC	IPFC 109	EPIC-A 304	IPFC 306				
	150/5T	■	■	■	■	-	-								
	180/6T	■	■	■	■	-	-								
	200/7T	■	■	■	■	-	-								
	250/8T	■	■	■	■	-	-					-	IPFC 114	EPIC-A 306	
	280/9T	■	■	■	■	-	-								
	300/10T	■	■	■	■	-	-								
	350/11T	■	■	■	■	-	-								
	380/12T	■	■	■	■	-	-								
	400/14T	-	-	-	-	-	■								
	450/16T	-	-	-	-	-	■								
	550/18T	-	-	-	-	-	■								
	600/20T	-	-	-	-	-	■		-	-	EPIC-A 309	IPFC 309			
U 7	180/4T	■	■	■	■	-	-	EPIC	IPFC 109	EPIC-A 304	IPFC 306				
	250/5T	■	■	■	■	-	-								
	300/6T	■	■	■	■	-	-		-	IPFC 114	EPIC-A 306				
	350/7T	■	■	■	■	-	-								
	400/8T	■	■	■	■	-	-								
	450/9T	■	■	■	■	-	-								
	550/10T	■	■	■	■	-	-								
	750/12T	-	-	-	-	-	■								
	800/14T	-	-	-	-	-	■								
	900/16T	-	-	-	-	-	■								
	950/18T	-	-	-	-	-	■								
	1000/20T	-	-	-	-	-	■					-	-	EPIC-A 309	IPFC 309
U 9	200/4T	■	■	■	■	-	-	EPIC	IPFC 109	EPIC-A 304	IPFC 306				
	250/5T	■	■	■	■	-	-								
	300/6T	■	■	■	■	-	-		-	IPFC 114	EPIC-A 306				
	400/7T	■	■	■	■	-	-								
	450/8T	■	■	■	■	-	-								
	500/9T	■	■	■	■	-	-								
	550/10T	■	-	■	-	-	-								
	750/12T	-	-	-	-	-	■								
	800/14T	-	-	-	-	-	■								
	900/16T	-	-	-	-	-	■								
	950/18T	-	-	-	-	-	■								
	1000/20T	-	-	-	-	-	■					-	-	EPIC-A 309	IPFC 309
															IPFC 311
										IPFC 314					
										IPFC 318					



# ULTRA+VSD

		3- PUMP							VSD TYPE		
TYPE		VERSION							Power supply		
		V	SV	L	SL/SLX	LG	HS	HX	1-230V	3-400V	
U 18	100/1T	-	-	-	-	-	-	■	IPFC 109	EPIC-A 304	IPFC 306
	200/2T	-	-	-	-	-	-	■			
	300/3T	-	-	-	-	-	-	■			
	250/3T	■	■	■	■	-	-	-	IPFC 114	EPIC-A 306	
	400/4T	-	-	-	-	-	-	■			
	450/5T	■	■	■	■	-	-	-	-	-	
	550/5T	-	-	-	-	-	-	■			
	550/6T	■	■	■	■	-	-	-			
	750/6T	-	-	-	-	-	-	■			IPFC 311
	750/7T	-	-	-	-	-	-	■			
	750/8T	■	■	■	■	-	-	-			IPFC 314
	1000/8T	-	-	-	-	-	-	■			
	1000/9T	-	-	-	-	-	-	■			
	900/9T	■	■	■	■	-	-	-			IPFC 318
	920/10T	-	-	-	-	■	-	-			
	1000/11T	-	-	-	-	■	-	-			
	1500/10T	-	-	-	-	-	-	■			
	1500/11T	-	-	-	-	-	-	■			
	1500/12T	-	-	-	-	-	-	■			
	1500/13T	-	-	-	-	-	-	■			IPFC 325
1500/14T	-	-	-	-	-	-	■				
2000/15T	-	-	-	-	-	-	■				
2000/16T	-	-	-	-	-	-	■				
2000/17T	-	-	-	-	-	-	■	IPFC 330			
U 22	200/1T	-	-	-	-	-	-	■	IPFC 109	-	IPFC 306
	300/2T	-	-	-	-	-	-	■			
	400/3T	-	-	-	-	-	-	■	IPFC 114		IPFC 309
	550/4T	-	-	-	-	-	-	■			
	750/5T	-	-	-	-	-	-	■	IPFC 311		
	1000/6T	-	-	-	-	-	-	■			
	1000/7T	-	-	-	-	-	-	■	IPFC 314		
	1500/8T	-	-	-	-	-	-	■			
	1500/9T	-	-	-	-	-	-	■	IPFC 318		
	1500/10T	-	-	-	-	-	-	■			
	2000/11T	-	-	-	-	-	-	■	IPFC 325		
	2000/12T	-	-	-	-	-	-	■			
	2000/13T	-	-	-	-	-	-	■			
	2000/14T	-	-	-	-	-	-	■			



		3- PUMP							VSD TYPE		
TYPE		VERSION							Power supply		
		V	SV	L	SL/SLX	LG	HS	HX	1-230V	3-400V	
U 35	300/1T	-	-	-	-	-	■	■	-	IPFC 114	IPFC 306
	550/2-2RT	-	-	-	-	-	■	■		IPFC 309	
	550/2-1RT	-	-	-	-	-	■	■		IPFC 311	
	750/2T	-	-	-	-	-	■	■		IPFC 314	
	750/3-2RT	-	-	-	-	-	■	■		IPFC 318	
	1000/3-1RT	-	-	-	-	-	■	■		IPFC 325	
	1000/3T	-	-	-	-	-	■	■			
	1000/4-2RT	-	-	-	-	-	■	■		IPFC 330	
	1500/4-1RT	-	-	-	-	-	■	■			
	1500/4T	-	-	-	-	-	■	■			
	1500/5-2RT	-	-	-	-	-	■	■			
	1500/5-1RT	-	-	-	-	-	■	■			
	2000/5T	-	-	-	-	-	■	■			
	2000/6-2RT	-	-	-	-	-	■	■			
	2000/6-1RT	-	-	-	-	-	■	■			
	2000/6T	-	-	-	-	-	■	■			
2000/7-2RT	-	-	-	-	-	■	■				
2000/7-1RT	-	-	-	-	-	■	■				
U 50	400/1-1RT	-	-	-	-	-	■	■	-	IPFC 114	IPFC 306
	550/1T	-	-	-	-	-	■	■		IPFC 309	
	750/2-2RT	-	-	-	-	-	■	■		IPFC 311	
	1000/2T	-	-	-	-	-	■	■		IPFC 318	
	1500/3-2RT	-	-	-	-	-	■	■		IPFC 325	
	1500/3T	-	-	-	-	-	■	■		IPFC 330	
	2000/4-2RT	-	-	-	-	-	■	■			
	2000/4T	-	-	-	-	-	■	■			
	2500/5-2RT	-	-	-	-	-	■	■			
	2500/5T	-	-	-	-	-	■	■			
	3000/6-2RT	-	-	-	-	-	■	■			
	3000/6T	-	-	-	-	-	■	■			
	4000/7-2RT	-	-	-	-	-	■	■			
U 75	550/1-1RT	-	-	-	-	-	■	■	-		IPFC 309
	750/1T	-	-	-	-	-	■	■		IPFC 311	
	1000/2-2RT	-	-	-	-	-	■	■		IPFC 318	
	1500/2-1RT	-	-	-	-	-	■	■		IPFC 325	
	1500/2T	-	-	-	-	-	■	■		IPFC 330	
	2000/3-2RT	-	-	-	-	-	■	■			
	2000/3-1RT	-	-	-	-	-	■	■			
	2500/3T	-	-	-	-	-	■	■			
	2500/4-2RT	-	-	-	-	-	■	■			
	3000/4-1RT	-	-	-	-	-	■	■			
	3000/4T	-	-	-	-	-	■	■			
4000/5-2RT	-	-	-	-	-	■	■				
U 90	750/1-1RT	-	-	-	-	-	■	■	-		IPFC 311
	1000/1T	-	-	-	-	-	■	■		IPFC 318	
	1500/2-2RT	-	-	-	-	-	■	■		IPFC 325	
	2000/2T	-	-	-	-	-	■	■		IPFC 330	