



Introduction to the VP line

Pentax offers a line of **vertical axis pumps** recently improved in hydraulic design and implemented with new models and solutions specifically developed for various industries such as firefighting equipment, petrochemical, mining plants, power plants.

High efficiency, reliability, and extreme ruggedness, are the main strengths of this suite. The VP line is available with electric motor and, through the Gear Box, with combustion engine.

This wide variety of versions and executions, with many materials available, makes this line of pumps extremely versatile for use in areas not served by electricity as emergency units or stock and all major industry sectors.

Technical operational characteristics for standard version

- All the hydraulic performance values below are guaranteed in accordance with standard ISO 9906-Grade 2 - Annex A
- The published hydraulic performance values do not take into account hydraulic leaking of the foot valves and axis lines
- The allowable **content of solids** in the pumped liquid is 40 g/m³
- The **maximum working time** with closed nozzle is 4 min
- All the components wetted with liquid are available in various types of **steel** and **bronze alloy**



Main characteristics of the HP line

- + Capacity up to 1.600 m³/h
- + Pressure up to 400 m
- + Thrust bearing (grease or oil with optional external cooling) for use of standard engines
- + Axis lines with **threaded or tapered joints** for reliable and durable connection of the shaft
- + Special **bushings** resistant to the wear of abrasive liquids and temperatures up to 180°C
- + **Control unit** for electric motor, transmission angle or pulley
- + **AISI 420 stainless steel shaft** for standard versions
- + All the models in the range are available in cast iron, bronze and all kinds of stainless steel, including Duplex

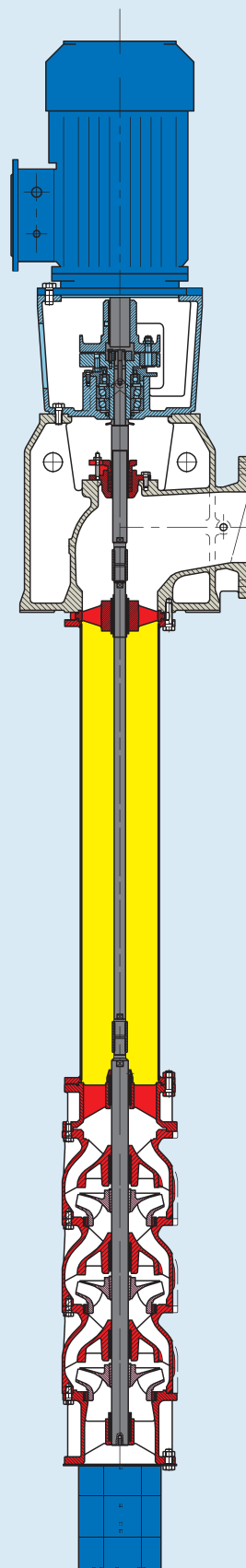

Main fields of application



Pumping units for fire-extinguishing equipment



Geothermal water wells



Water mains



Petrochemical sector



Agricultural irrigation



Chemical systems with aggressive and/or abrasive liquids



Mines



Heat treatment facilities for steel factories and/or abrasive liquids



Main technical and constructional features

The **impeller** is available in **radial** or **semi-axial version** for maximum yield in the required working point. On the mouth it has a wearing ring that guarantees high efficiency and low wear even with abrasive liquids.

To allow maintenance and disassembly ease, even after years of use, it is secured on the shaft with a tapered bushing that guarantees a perfect alignment.

Radial flow impeller

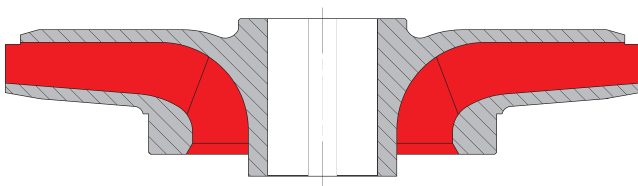

Semi-axial flow impeller

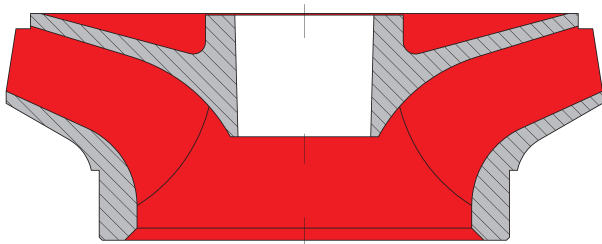

The **diffuser**, designed to grant high efficiency of the pump, has an abrasion resistant rubber bearing that guarantees long life-span of the shaft.

For extremely demanding applications “Ferroform” bearings are available on request.

Semi-axial flow diffuser

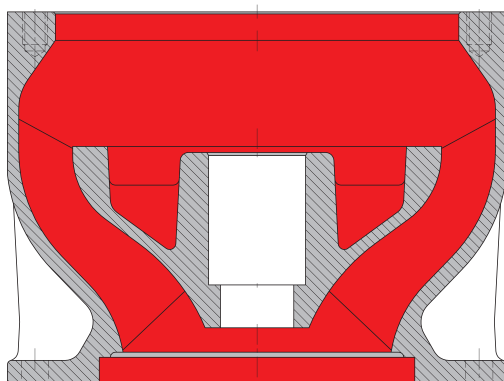

Axis line houses the transmission shaft on special rubber bearings to ensure optimal lubrication. To optimize its life time, the shaft is protected by a chromed steel shield.

The modules of the axis lines are interconnected with screwed or tapered joints that guarantee perfect alignment and maintenance ease.

A: abrasion resistant bushing

B: chromed sleeve

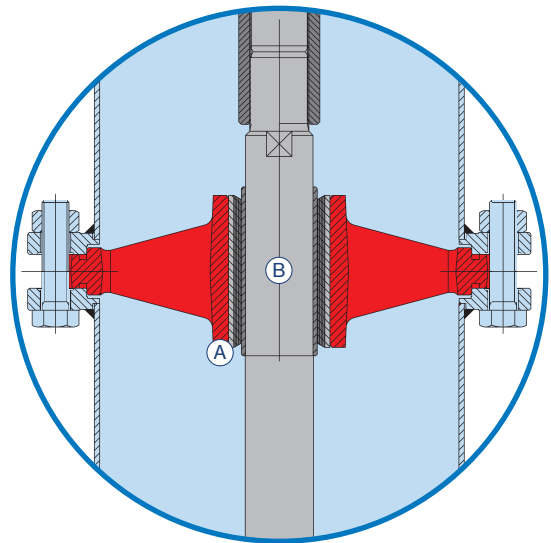

The **conic coupling** is used for all heavy duty applications since it allows a perfect alignment of the shafts and performs with big transmitted power factor; moreover this type of coupling is very simple to service and disassemble even after many years of activity.

Conic coupling

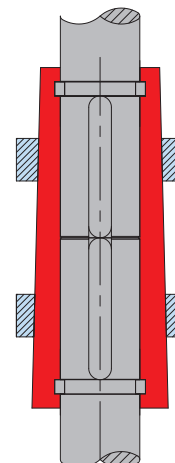

Delivery drive unit is a highly important part of the pump as it houses the sealing system and the thrust bearing.

Available in the version for electric motor or with gear box it has a type of bearing, grease or oil depending on the application, that can withstand axial thrust up to 10,000 kg. The oil version permits external cooling of the liquid lubricant. The seals can be of packing or mechanical seal type.

Drive unit

- A: thrust bearing
- B: seal system
- C: shaft coupling

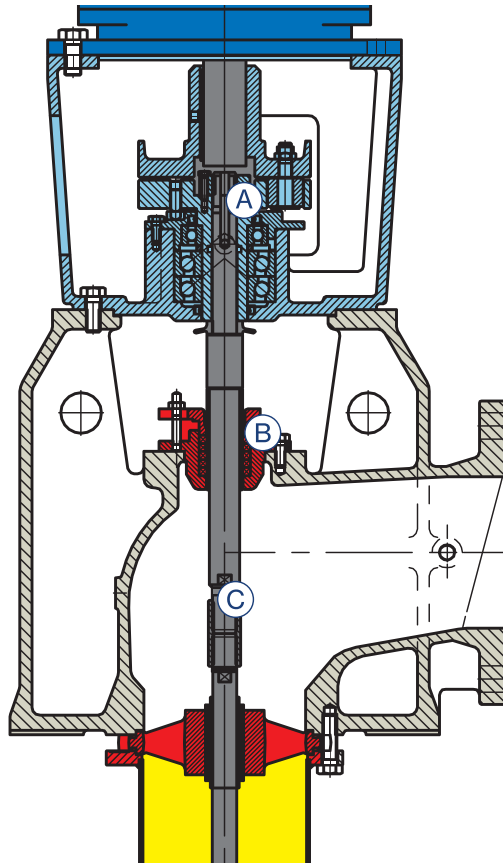

The seals can be of packing or mechanical seal type.

The packing type is lubricated by the pumped liquid or externally by means of a dedicated injection device. Mechanical seal, available in all the materials available in the market, has an axial positioning device that guarantee its perfect operation.

Gland packing seal

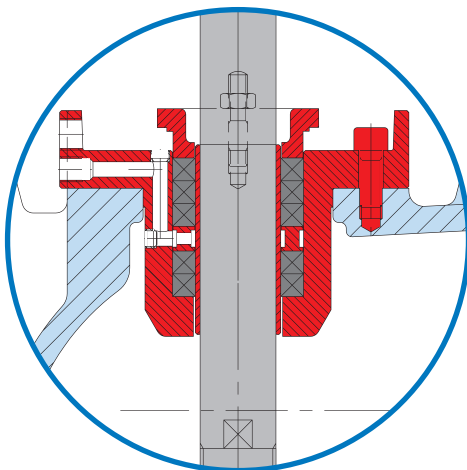

Mechanical seal

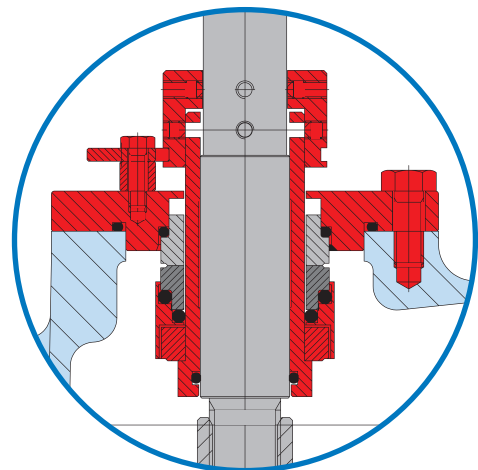

Mechanical seal material

The mechanical seals are standardized according to EN 12756 and available on “Balanced” and “Non-balanced” types, with model codes MG12 e H7N.

Model MG12 - bi-directional non-balanced

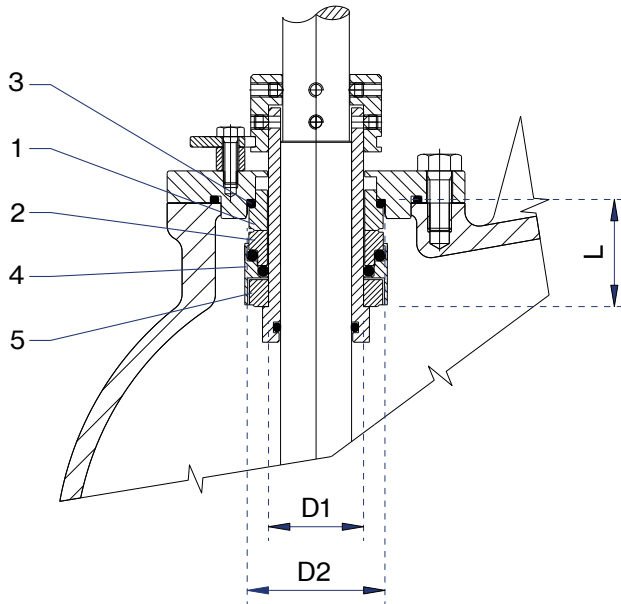

Model H7N - bi-directional balanced

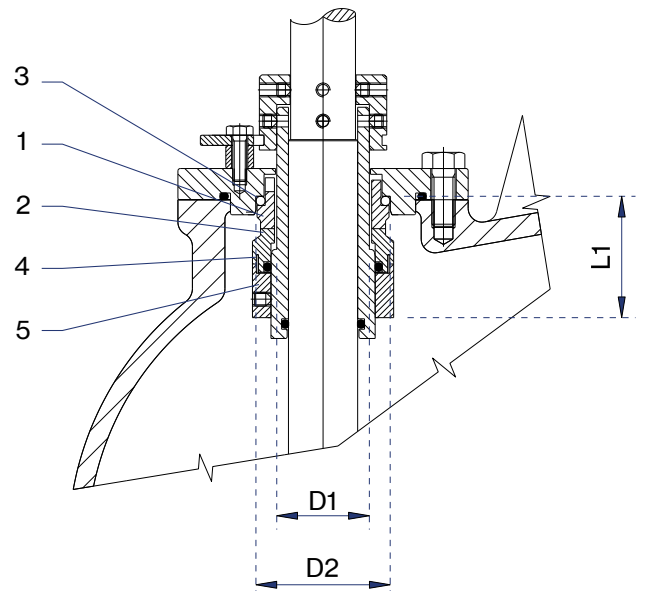

Mechanical seals materials			
	POSITION 1 - 2	POSITION 3	POSITION 4 - 5
A	Antimony impregnated Carbon	E : EPDM	G : AISI 316
Q1	Silicon-Carbide	V : FPM	

Available Materials Combinations : MG12 - H7N						
Type	POSITION					Temperature °C
	1	2	3	4	5	
	Rotating part	Stationary part	Elastomers	Spring	Other parts	
Standard mechanical seal						
AQ1EGG	A	Q1	E	G	G	-30 +120
On demand mechanical seals						
AQ1VGG	A	Q1	V	G	G	-10 +120
Q1Q1EGG	Q1	Q1	E	G	G	-30 +120
Q1Q1VGG	Q1	Q1	V	G	G	-10 +120

Dimensions			
D1	D2	L	L1
28	43	42.5	50
30	45	42.5	50
32	48	42.5	50
35	50	42.5	50
40	58	45	52.5
45	63	45	52.5
50	70	47.5	57.5
55	75	47.5	57.5
60	80	52.5	62.5



Pump unit materials

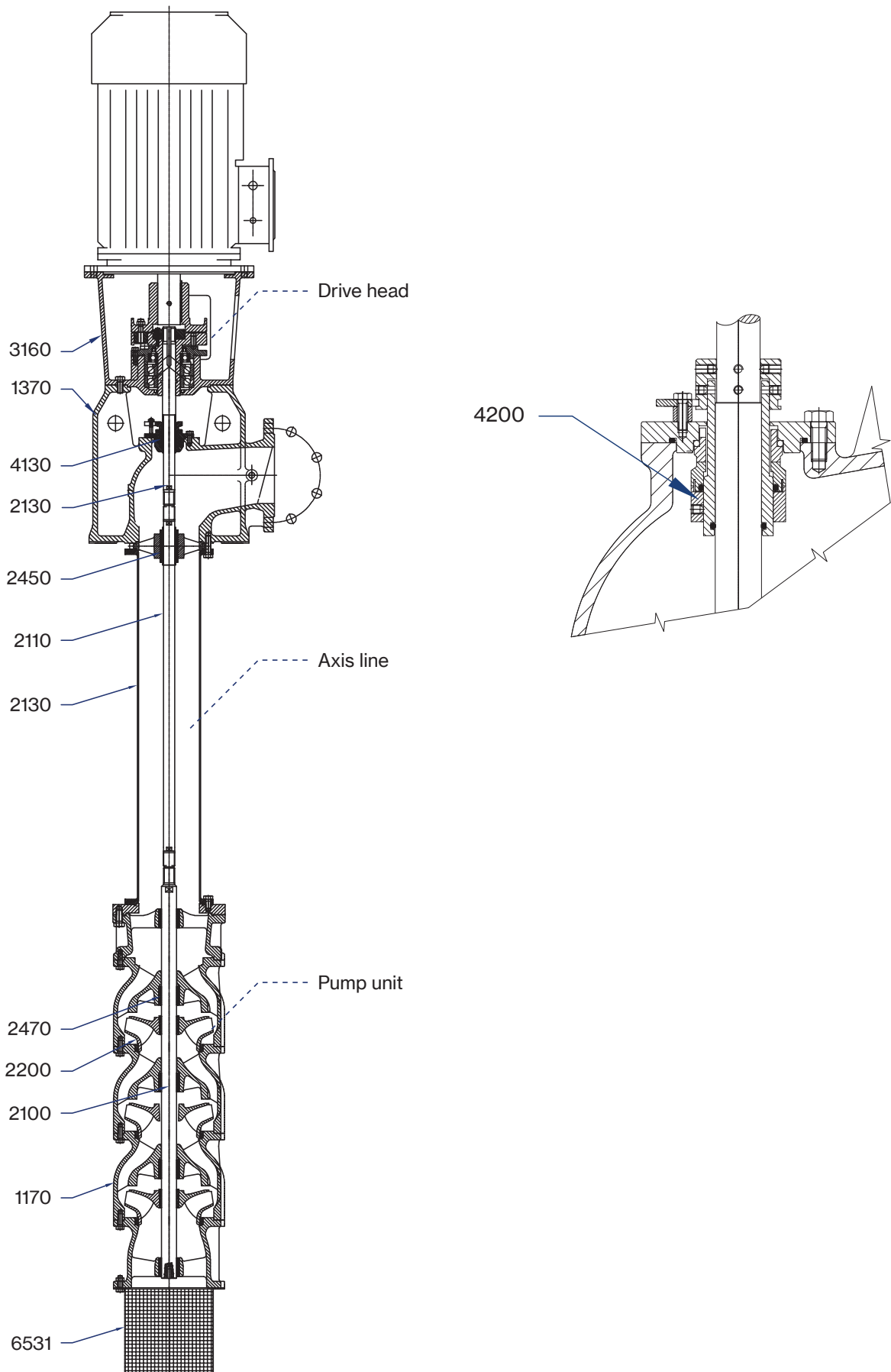

PUMP UNIT MATERIALS

Unit description	Part description	Ref.	STANDARD		OPTIONAL			
					Execution "X" AISI		Execution "D" Duplex	
			EN	ASTM	EN	ASTM	EN	ASTM
Drive head	Delivery unit	1370	G GG42	A536 : Gr.65-A5-12	X2CrNiMo1711	316	X2CrNiMoN2253	S31803
	Shaft	2130	X 30 Cr13	420	X 30 Cr13	420	X2CrNiMoN2253	S31803
	Motor bracket	3160	G GG42	A536 : Gr.65-A5-12	G GG42	A536 : Gr.65-A5-12	G GG42	A536 : Gr.65-A5-12
Seals system	Gland packing	4130	COTTON + GRAPHITE		PTFE		PTFE	
	Mechanical seal	4200	SILICON + SILICON + EPDM		SILICON + SILICON + EPDM		SILICON + SILICON + EPDM	
Axis line	Shaft	2110	X 30 Cr13	420	X 30 Cr13	420	X2CrNiMoN2253	S31803
	Pipe	2130	P235TR1	A 53 Grade A	X2CrNiMo1711	316	X2CrNiMoN2253	S31803
	Bushing	2450	Rubber		Feroform		Feroform	
Pump unit	Diffuser	1170	G G25	A48 : Nr.35	X2CrNiMo1711	316	X2CrNiMoN2253	S31803
	Shaft	2100	X 30 Cr13	420	X 30 Cr13	420	X2CrNiMoN2253	S31803
	Impeller	2200	G G25	A48 : Nr.35	X2CrNiMo1711	316	X2CrNiMoN2253	S31803
	Bushing	2470	Rubber		PeeK		PeeK	
	Strainer	6531	X5CrNi1810	304	X2CrNiMo1711	316	X2CrNiMoN2253	S31803

Name key

VPLX 12A / 8D-T - 18-CO-4-X-6

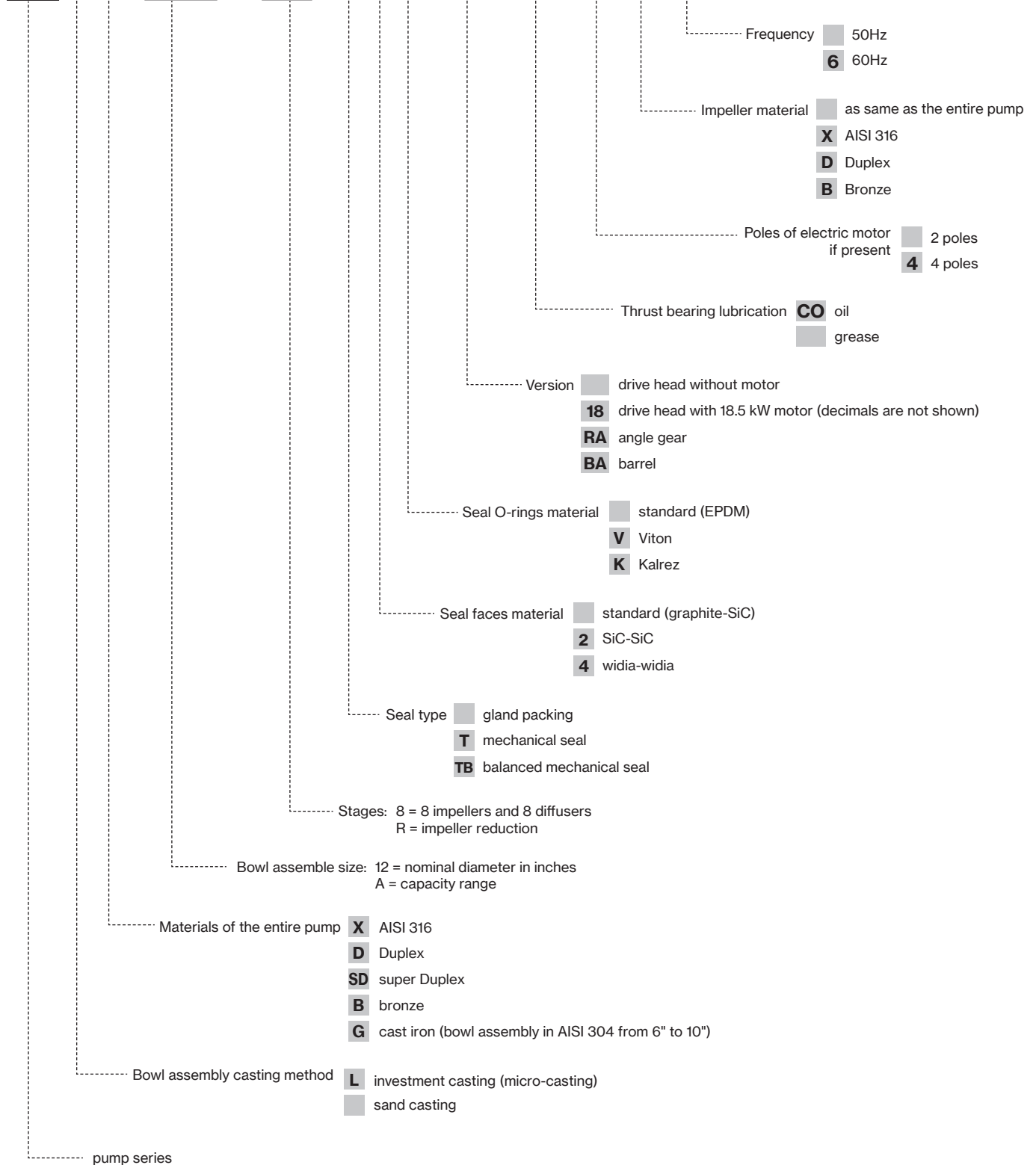

Performance range 1.500 rpm

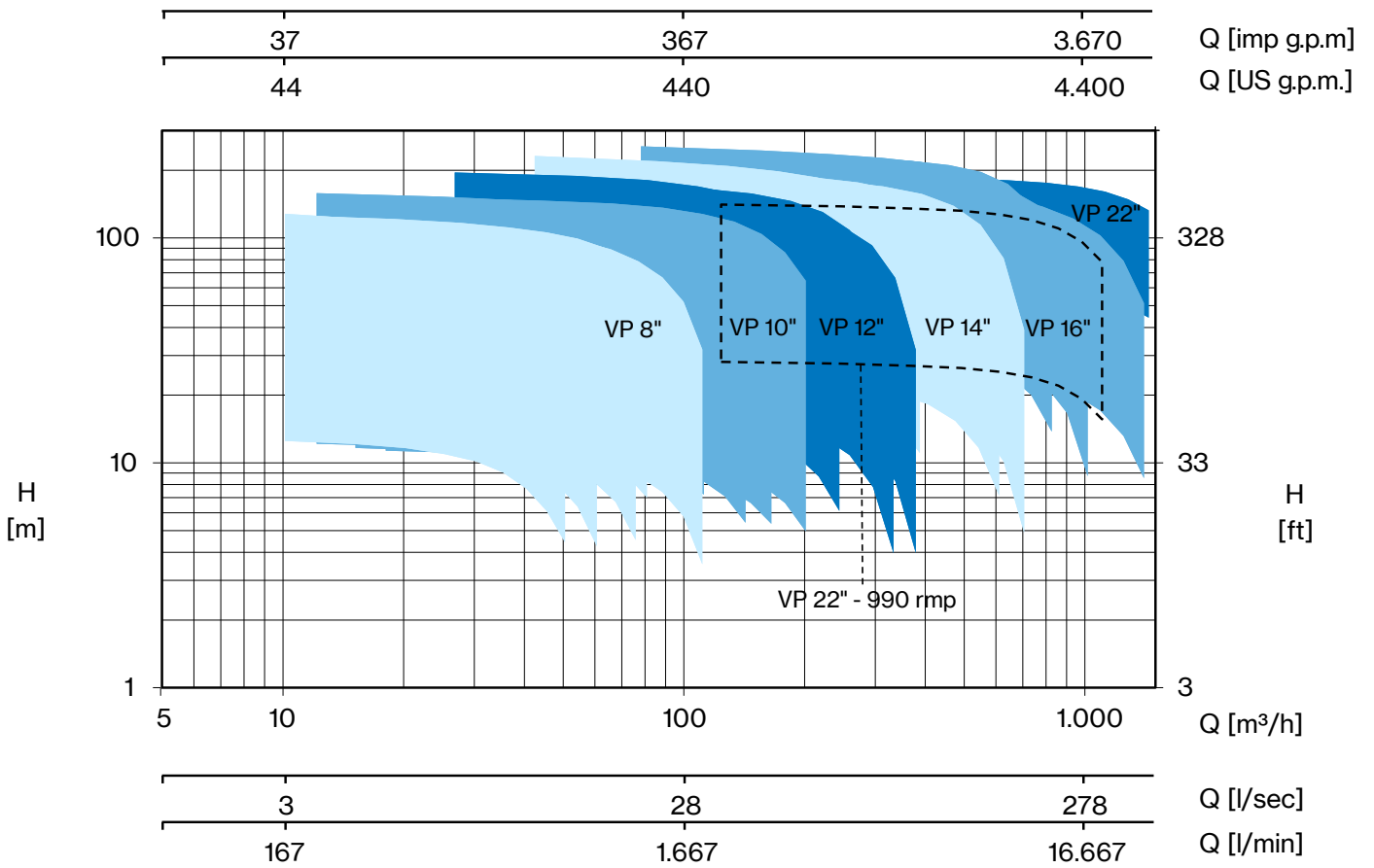

VP 14A 1.480 rpm

1.480 rpm		Q										
TYPE	kW	m³/h	0	42	84	129	171	213	255	300	342	384
		l/sec	0	11,7	23,3	35,8	47,5	59,2	70,8	83,3	95,0	106,7
		l/min	0	700	1.400	2.150	2.850	3.550	4.250	5.000	5.700	6.400
		H (m) / P1 (kW)										
VP 14A / 1L	11	H (m) / P1 (kW)	19,3	17,9	16,7	15,4	14,0	12,2	9,6			
			6,6	6,6	7,2	8,1	8,9	9,3	9,1			
VP 14A / 1F	15		22,7	21,2	20,0	18,7	17,5	16,0	14,0	11,2		
			8,9	8,9	9,5	10,4	11,4	12,2	12,7	12,4		
VP 14A / 1C	18,5		25,2	23,7	22,4	21,2	20,0	18,6	16,9	14,6	11,7	
			10,9	10,8	11,4	12,3	13,4	14,4	15,2	15,4	14,9	
VP 14A / 1	18,5		26,8	25,3	24,0	22,8	21,6	20,3	18,7	16,6	14,1	10,9
			12,3	12,2	12,8	13,8	14,9	16,0	16,9	17,4	17,3	16,2
VP 14A / 2L	22		38,7	35,8	33,4	30,9	28,0	24,3	19,2			
			13,2	13,2	14,4	16,2	17,7	18,6	18,3			
VP 14A / 2F	30		45,4	42,4	39,9	37,5	35,0	31,9	28,0	22,4		
			17,9	17,8	18,9	20,9	22,8	24,5	25,3	24,7		
VP 14A / 2C	37		50,3	47,3	44,8	42,3	40,0	37,2	33,8	29,1	23,5	
			21,8	21,6	22,7	24,7	26,8	28,9	30,3	30,8	29,7	
VP 14A / 2	37		53,6	50,6	48,0	45,5	43,2	40,6	37,4	33,2	28,1	21,8
			24,7	24,5	25,5	27,5	29,8	32,1	33,9	34,9	34,5	32,5
VP 14A / 3L	30		58,0	53,6	50,1	46,3	42,1	36,5	28,8			
			19,8	19,9	21,6	24,3	26,6	28,0	27,4			
VP 14A / 3F	45		68,1	63,6	59,9	56,2	52,5	47,9	42,0	33,6		
		26,8	26,7	28,4	31,3	34,2	36,7	38,0	37,1			
VP 14A / 3C	55	75,5	71,0	67,2	63,5	59,9	55,8	50,7	43,7	35,2		
		32,7	32,5	34,1	37,0	40,3	43,3	45,5	46,2	44,6		
VP 14A / 3	55	80,4	75,9	72,0	68,3	64,8	60,8	56,1	49,7	42,2	32,7	
		37,0	36,7	38,3	41,3	44,7	48,1	50,8	52,3	51,8	48,7	
VP 14A / 4F	55	90,8	84,8	79,9	75,0	70,0	63,9	56,0	44,8			
		35,8	35,7	37,9	41,7	45,7	48,9	50,6	49,5			
VP 14A / 4C	75	100,7	94,7	89,6	84,7	79,9	74,4	67,6	58,2	46,9		
		43,6	43,3	45,4	49,4	53,7	57,8	60,7	61,6	59,4		
VP 14A / 4	75	107,2	101,1	96,0	91,1	86,4	81,1	74,8	66,3	56,2	43,6	
		49,4	49,0	51,0	55,1	59,6	64,1	67,8	69,8	69,0	64,9	
VP 14A / 5C	90	125,9	118,3	112,0	105,9	99,9	93,0	84,5	72,8	58,6		
		54,5	54,1	56,8	61,7	67,1	72,2	75,9	77,0	74,3		
VP 14A / 5	90	134,0	126,4	120,0	113,8	108,0	101,4	93,5	82,9	70,3	54,5	
		61,7	61,2	63,8	68,8	74,5	80,1	84,7	87,2	86,3	81,2	
VP 14A / 6	110	160,8	151,7	144,1	136,6	129,6	121,7	112,2	99,5	84,4	65,4	
		74,0	73,5	76,6	82,6	89,4	96,2	101,6	104,7	103,5	97,4	
VP 14A / 7	132	187,6	177,0	168,1	159,4	151,2	142,0	130,9	116,1	98,4	76,3	
		86,4	85,7	89,3	96,3	104,3	112,2	118,6	122,1	120,8	113,6	
VP 14A / 8	160	214,4	202,3	192,1	182,1	172,8	162,3	149,6	132,6	112,5	87,2	
		98,7	97,9	102,1	110,1	119,2	128,2	135,5	139,6	138,1	129,8	
VP 14A / 9	160	241,2	227,6	216,1	204,9	194,4	182,5	168,3	149,2	126,5	98,1	
		111,1	110,2	114,8	123,9	134,1	144,3	152,5	157,0	155,3	146,1	

MOTOR		Axis line	Drive unit	Base	Flange discharge	Foot valve	Strainer
kW	Gr. / Size						
5,5 - 7,5	132	LA 6/24	E 2/6	B 6/6	DN 150 - PN 25	VF9	SU9
11 - 15	160	LA 6/24	E 3/6				
18,5 - 22	180	LA 6/24	E 4/6				
30	200	LA 6/30	E 5/6				
37 - 45	225	LA 6/30	E 6/6				
55	250	LA 6/35	E 7/6				
75	280	LA 6/35	E 7/6				
90	280	LA 8/40	E 7/8	B 8/8	DN 200 - PN 25		
110	315	LA 8/40	E 8/8				
132 - 160	315	LA 8/45	E 8/8				
200	315	LA 10/50	E 8/10	B 10/10	DN 250 - PN 25		



VP 14A 1.480 rpm

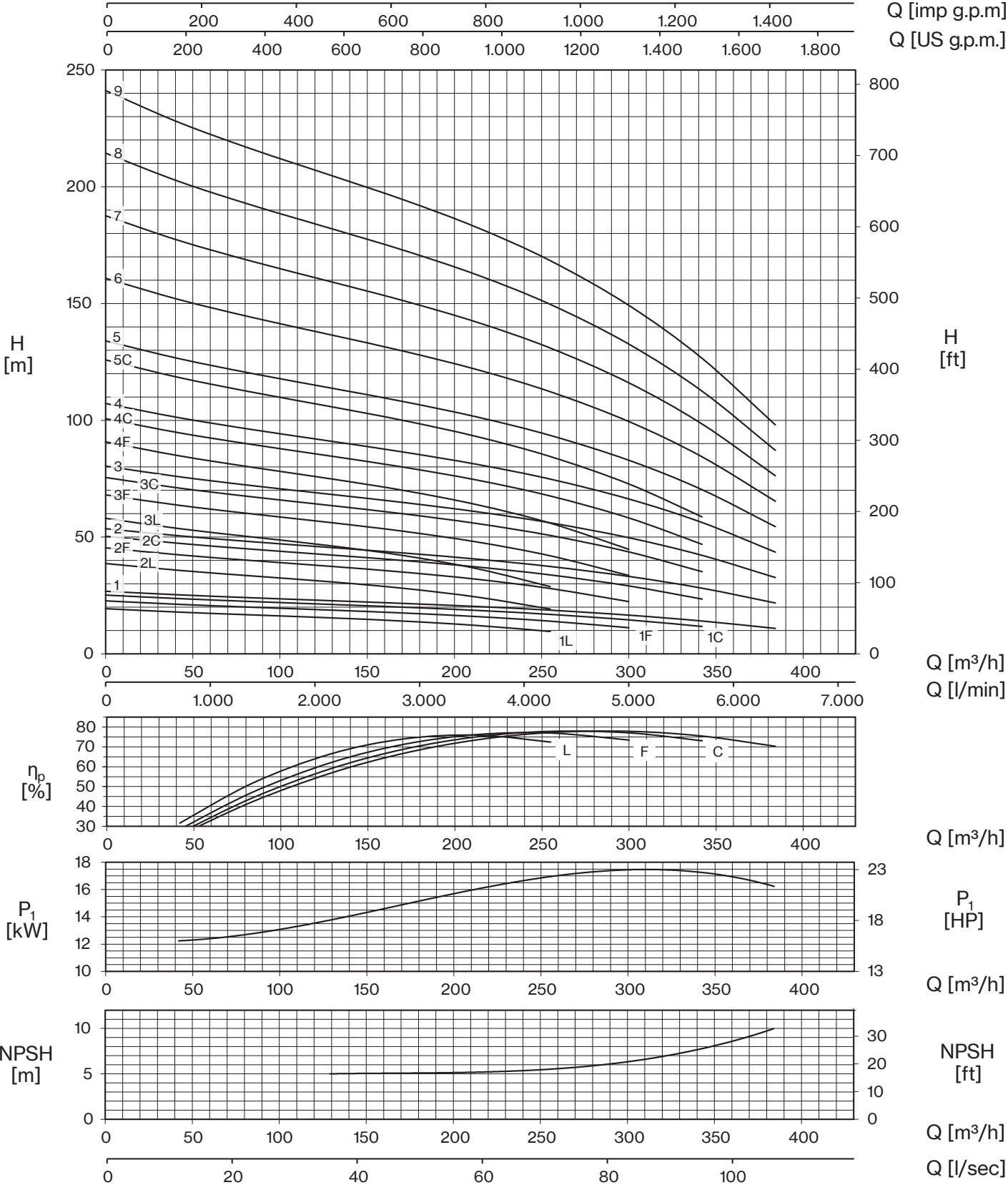

Valid for: $\rho=1$ (kg/dm³), viscosity ≤ 20 mm²/sec - Guarantee values according to ISO 9906, Grade 2 - Head based on SG=1



VP 14B 1.480 rpm

1.480 rpm		Q										
TYPE	kW	m³/h	0	66	132	201	267	333	399	468	534	600
		l/sec	0	18,3	36,7	55,8	74,2	92,5	110,8	130,0	148,3	166,7
		l/min	0	1.100	2.200	3.350	4.450	5.550	6.650	7.800	8.900	10.000
		H (m) / P1 (kW)										
VP 14B / 1L	15	H (m) / P1 (kW)	19,0 <i>9,0</i>	18,0 <i>9,8</i>	17,0 <i>10,9</i>	15,6 <i>12,1</i>	13,8 <i>13,0</i>	11,2 <i>13,4</i>	7,5 <i>13,1</i>			
VP 14B / 1F	18,5		22,3 <i>12,2</i>	21,3 <i>13,1</i>	20,3 <i>14,3</i>	19,0 <i>15,7</i>	17,5 <i>16,9</i>	15,5 <i>17,8</i>	12,7 <i>18,2</i>	8,8 <i>17,8</i>		
VP 14B / 1C	30		24,8 <i>14,9</i>	23,7 <i>15,8</i>	22,7 <i>17,1</i>	21,5 <i>18,6</i>	20,2 <i>20,1</i>	18,4 <i>21,2</i>	16,0 <i>22,0</i>	12,8 <i>22,1</i>	8,8 <i>21,4</i>	
VP 14B / 1	30		26,4 <i>16,9</i>	25,3 <i>17,9</i>	24,3 <i>19,2</i>	23,2 <i>20,8</i>	21,9 <i>22,4</i>	20,2 <i>23,7</i>	18,1 <i>24,7</i>	15,2 <i>25,1</i>	11,6 <i>24,8</i>	7,1 <i>23,6</i>
VP 14B / 2L	30		38,1 <i>18,1</i>	36,0 <i>19,6</i>	33,9 <i>21,8</i>	31,2 <i>24,2</i>	27,5 <i>26,0</i>	22,3 <i>26,9</i>	15,0 <i>26,2</i>			
VP 14B / 2F	37		44,7 <i>24,5</i>	42,6 <i>26,2</i>	40,5 <i>28,7</i>	38,1 <i>31,4</i>	35,1 <i>33,9</i>	31,0 <i>35,7</i>	25,4 <i>36,4</i>	17,7 <i>35,6</i>		
VP 14B / 2C	45		49,6 <i>29,8</i>	47,4 <i>31,7</i>	45,4 <i>34,3</i>	43,1 <i>37,3</i>	40,3 <i>40,1</i>	36,8 <i>42,5</i>	32,1 <i>44,0</i>	25,6 <i>44,3</i>	17,6 <i>42,8</i>	
VP 14B / 2	55		52,8 <i>33,8</i>	50,6 <i>35,7</i>	48,6 <i>38,4</i>	46,3 <i>41,6</i>	43,7 <i>44,7</i>	40,4 <i>47,4</i>	36,1 <i>49,4</i>	30,3 <i>50,2</i>	23,2 <i>49,6</i>	14,2 <i>47,1</i>
VP 14B / 3L	45		57,1 <i>27,1</i>	54,0 <i>29,4</i>	50,9 <i>32,7</i>	46,8 <i>36,3</i>	41,3 <i>39,0</i>	33,5 <i>40,3</i>	22,6 <i>39,4</i>			
VP 14B / 3F	55		67,0 <i>36,7</i>	63,8 <i>39,3</i>	60,8 <i>43,0</i>	57,1 <i>47,1</i>	52,6 <i>50,8</i>	46,4 <i>53,5</i>	38,1 <i>54,6</i>	26,5 <i>53,4</i>		
VP 14B / 3C	75		74,4 <i>44,7</i>	71,1 <i>47,5</i>	68,1 <i>51,4</i>	64,6 <i>55,9</i>	60,5 <i>60,2</i>	55,2 <i>63,7</i>	48,1 <i>66,0</i>	38,4 <i>66,4</i>	26,4 <i>64,3</i>	
VP 14B / 3	90		79,2 <i>50,7</i>	75,9 <i>53,6</i>	72,9 <i>57,7</i>	69,5 <i>62,5</i>	65,6 <i>67,1</i>	60,6 <i>71,1</i>	54,2 <i>74,1</i>	45,5 <i>75,4</i>	34,8 <i>74,4</i>	21,3 <i>70,7</i>
VP 14B / 4F	75		89,4 <i>49,0</i>	85,1 <i>52,5</i>	81,1 <i>57,3</i>	76,2 <i>62,9</i>	70,1 <i>67,8</i>	61,9 <i>71,4</i>	50,8 <i>72,8</i>	35,3 <i>71,2</i>		
VP 14B / 4C	90		99,1 <i>59,6</i>	94,9 <i>63,4</i>	90,8 <i>68,5</i>	86,2 <i>74,6</i>	80,7 <i>80,2</i>	73,5 <i>85,0</i>	64,1 <i>88,0</i>	51,2 <i>88,5</i>	35,2 <i>85,7</i>	
VP 14B / 4	110		105,5 <i>67,6</i>	101,2 <i>71,5</i>	97,2 <i>76,9</i>	92,7 <i>83,3</i>	87,5 <i>89,4</i>	80,8 <i>94,8</i>	72,3 <i>98,7</i>	60,6 <i>100,5</i>	46,3 <i>99,2</i>	28,5 <i>94,2</i>
VP 14B / 5C	132		123,9 <i>74,5</i>	118,6 <i>79,2</i>	113,5 <i>85,7</i>	107,7 <i>93,2</i>	100,8 <i>100,3</i>	91,9 <i>106,2</i>	80,2 <i>110,0</i>	64,0 <i>110,6</i>	44,0 <i>107,1</i>	
VP 14B / 5	132		131,9 <i>84,5</i>	126,6 <i>89,4</i>	121,5 <i>96,1</i>	115,8 <i>104,1</i>	109,3 <i>111,8</i>	101,0 <i>118,5</i>	90,3 <i>123,4</i>	75,8 <i>125,6</i>	57,9 <i>124,0</i>	35,6 <i>117,8</i>
VP 14B / 6	160		158,3 <i>101,3</i>	151,9 <i>107,2</i>	145,8 <i>115,3</i>	139,0 <i>124,9</i>	131,2 <i>134,1</i>	121,3 <i>142,2</i>	108,4 <i>148,1</i>	90,9 <i>150,7</i>	69,5 <i>148,8</i>	42,7 <i>141,3</i>
VP 14B / 7C	160		173,5 <i>104,3</i>	166,0 <i>110,9</i>	158,9 <i>119,9</i>	150,8 <i>130,5</i>	141,2 <i>140,4</i>	128,7 <i>148,7</i>	112,2 <i>154,0</i>	89,6 <i>154,9</i>	61,6 <i>149,9</i>	
VP 14B / 8E	160		186,6 <i>106,3</i>	178,1 <i>113,4</i>	169,9 <i>123,4</i>	160,4 <i>134,9</i>	148,8 <i>145,4</i>	133,3 <i>153,5</i>	112,6 <i>157,8</i>	83,9 <i>156,3</i>		

MOTOR		Axis line	Drive unit	Base	Flange discharge	Foot valve	Strainer
kW	Gr. / Size						
11 - 15	160	LA 10/30	E 3/10	B 10/10	DN 250 - PN 25	VF9	SU9
18,5 - 22	180	LA 10/30	E 4/10				
30	200	LA 10/30	E 5/10				
37 - 45	225	LA 10/30	E 6/10				
55	250	LA 10/35	E 7/10				
75	280	LA 10/35	E 7/10				
90	280	LA 10/40	E 7/10				
110	315	LA 10/40	E 8/10				
132 - 160	315	LA 10/45	E 8/10				
200	315	LA 10/50	E 8/10				



VP 14B 1.480 rpm

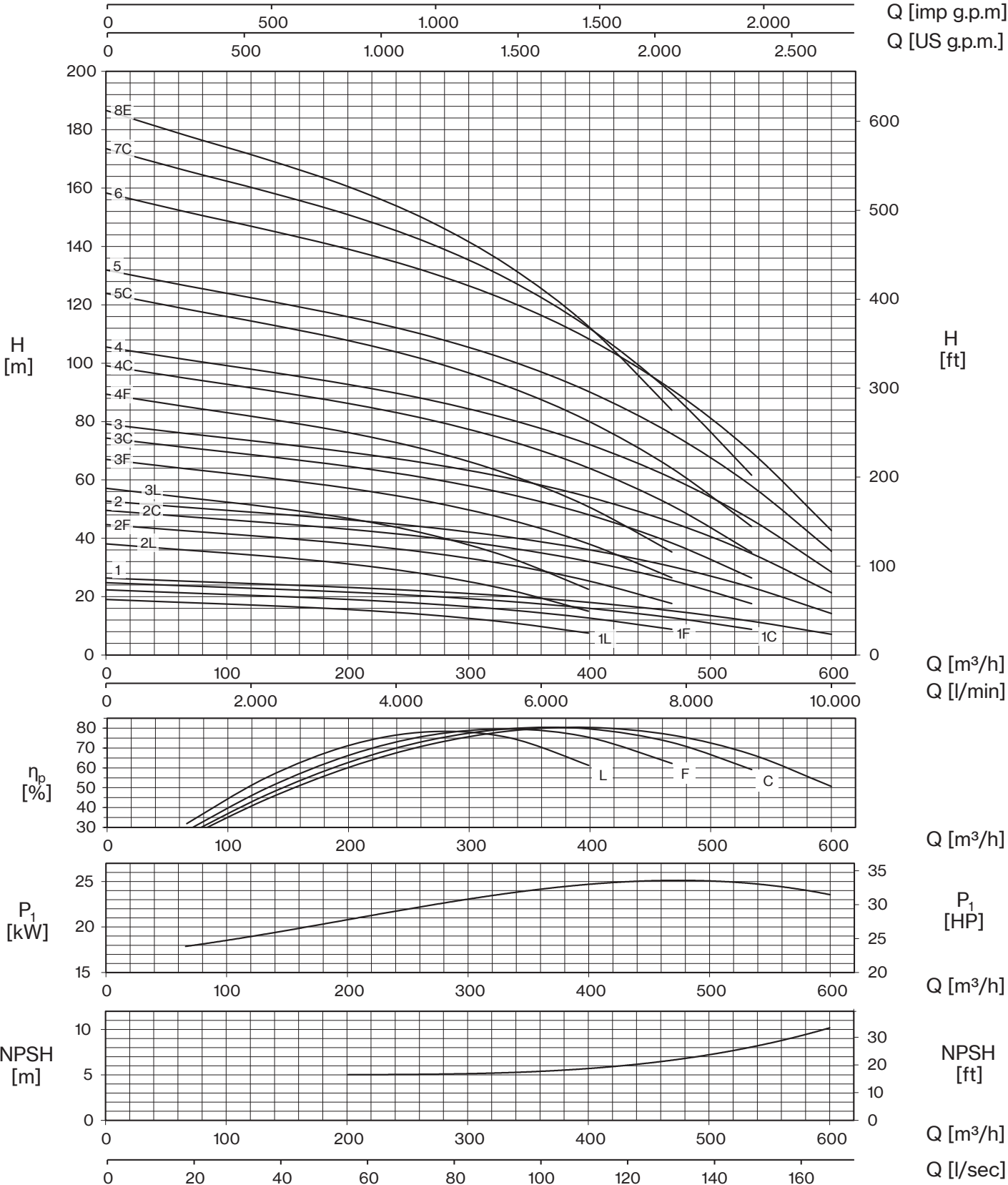

Valid for: ρ=1 (kg/dm³), viscosity ≤20 mm²/sec - Guarantee values according to ISO 9906, Grade 2 - Head based on SG=1



VP 14C 1.480 rpm

1.480 rpm		Q										
TYPE	kW	m³/h	0	78	156	234	312	387	465	543	621	699
		l/sec	0	21,7	43,3	65,0	86,7	107,5	129,2	150,8	172,5	194,2
		l/min	0	1.300	2.600	3.900	5.200	6.450	7.750	9.050	10.350	11.650
		H (m) / P1 (kW)										
VP 14C / 1L	15	H (m) / P1 (kW)	18,3 <i>10,1</i>	17,0 <i>10,8</i>	16,0 <i>11,9</i>	14,8 <i>13,1</i>	13,0 <i>14,0</i>	10,4 <i>14,4</i>	6,2 <i>14,0</i>			
VP 14C / 1F	22		21,5 <i>13,7</i>	20,2 <i>14,5</i>	19,2 <i>15,8</i>	18,1 <i>17,1</i>	16,7 <i>18,4</i>	14,7 <i>19,2</i>	11,8 <i>19,6</i>	7,6 <i>19,1</i>		
VP 14C / 1C	30		23,8 <i>16,7</i>	22,6 <i>17,6</i>	21,5 <i>18,9</i>	20,5 <i>20,4</i>	19,2 <i>21,8</i>	17,6 <i>23,0</i>	15,2 <i>23,8</i>	11,8 <i>23,9</i>	7,2 <i>23,1</i>	
VP 14C / 1	30		25,3 <i>18,8</i>	24,0 <i>19,8</i>	23,0 <i>21,1</i>	22,0 <i>22,7</i>	20,8 <i>24,3</i>	19,3 <i>25,6</i>	17,1 <i>26,6</i>	14,1 <i>27,0</i>	10,1 <i>26,5</i>	4,8 <i>25,1</i>
VP 14C / 2L	30		36,5 <i>20,1</i>	34,0 <i>21,6</i>	32,0 <i>23,8</i>	29,6 <i>26,1</i>	26,1 <i>28,0</i>	20,7 <i>28,7</i>	12,4 <i>28,0</i>			
VP 14C / 2F	45		42,9 <i>27,4</i>	40,4 <i>29,1</i>	38,3 <i>31,5</i>	36,2 <i>34,2</i>	33,4 <i>36,7</i>	29,5 <i>38,5</i>	23,5 <i>39,2</i>	15,1 <i>38,2</i>		
VP 14C / 2C	55		47,7 <i>33,4</i>	45,1 <i>35,2</i>	43,0 <i>37,8</i>	41,0 <i>40,8</i>	38,5 <i>43,7</i>	35,2 <i>46,0</i>	30,3 <i>47,5</i>	23,6 <i>47,7</i>	14,4 <i>46,1</i>	
VP 14C / 2	55		50,6 <i>37,7</i>	48,0 <i>39,6</i>	45,9 <i>42,3</i>	43,9 <i>45,4</i>	41,5 <i>48,5</i>	38,5 <i>51,2</i>	34,2 <i>53,1</i>	28,2 <i>53,9</i>	20,2 <i>53,1</i>	9,6 <i>50,2</i>
VP 14C / 3L	45		54,8 <i>30,2</i>	51,0 <i>32,4</i>	48,0 <i>35,7</i>	44,5 <i>39,2</i>	39,1 <i>42,0</i>	31,1 <i>43,1</i>	18,6 <i>42,0</i>			
VP 14C / 3F	75		64,4 <i>41,1</i>	60,6 <i>43,6</i>	57,5 <i>47,3</i>	54,3 <i>51,3</i>	50,1 <i>55,1</i>	44,2 <i>57,7</i>	35,3 <i>58,8</i>	22,7 <i>57,3</i>		
VP 14C / 3C	75		71,5 <i>50,2</i>	67,7 <i>52,9</i>	64,5 <i>56,7</i>	61,5 <i>61,2</i>	57,7 <i>65,5</i>	52,7 <i>69,0</i>	45,5 <i>71,3</i>	35,4 <i>71,6</i>	21,7 <i>69,2</i>	
VP 14C / 3	90		75,9 <i>56,5</i>	72,0 <i>59,3</i>	68,9 <i>63,4</i>	65,9 <i>68,1</i>	62,3 <i>72,8</i>	57,8 <i>76,7</i>	51,3 <i>79,7</i>	42,3 <i>80,9</i>	30,2 <i>79,6</i>	14,4 <i>75,3</i>
VP 14C / 4F	90		85,9 <i>54,8</i>	80,8 <i>58,1</i>	76,7 <i>63,0</i>	72,4 <i>68,4</i>	66,8 <i>73,5</i>	58,9 <i>77,0</i>	47,0 <i>78,3</i>	30,2 <i>76,4</i>		
VP 14C / 4C	110		95,4 <i>66,9</i>	90,2 <i>70,5</i>	86,1 <i>75,7</i>	82,0 <i>81,6</i>	76,9 <i>87,4</i>	70,3 <i>92,1</i>	60,7 <i>95,1</i>	47,2 <i>95,4</i>	28,9 <i>92,2</i>	
VP 14C / 4	110		101,2 <i>75,4</i>	96,0 <i>79,1</i>	91,8 <i>84,5</i>	87,8 <i>90,8</i>	83,1 <i>97,0</i>	77,0 <i>102,3</i>	68,3 <i>106,3</i>	56,4 <i>107,8</i>	40,3 <i>106,1</i>	19,2 <i>100,4</i>
VP 14C / 5C	132		119,2 <i>83,6</i>	112,8 <i>88,1</i>	107,6 <i>94,6</i>	102,5 <i>102,0</i>	96,2 <i>109,2</i>	87,9 <i>115,1</i>	75,8 <i>118,9</i>	59,0 <i>119,3</i>	36,1 <i>115,3</i>	
VP 14C / 5	160		126,5 <i>94,2</i>	120,0 <i>98,9</i>	114,8 <i>105,6</i>	109,8 <i>113,5</i>	103,8 <i>121,3</i>	96,3 <i>127,9</i>	85,4 <i>132,8</i>	70,5 <i>134,8</i>	50,4 <i>132,7</i>	24,0 <i>125,5</i>
VP 14C / 6A	160		149,1 <i>109,0</i>	141,3 <i>114,5</i>	135,0 <i>122,5</i>	128,9 <i>131,7</i>	121,7 <i>140,9</i>	112,4 <i>148,6</i>	98,9 <i>154,1</i>	80,3 <i>155,8</i>	55,2 <i>152,6</i>	
VP 14C / 7D	160		163,1 <i>112,1</i>	154,1 <i>118,2</i>	146,9 <i>127,2</i>	139,7 <i>137,4</i>	130,7 <i>147,3</i>	118,7 <i>155,0</i>	101,0 <i>159,7</i>	76,2 <i>159,5</i>	42,6 <i>152,7</i>	
VP 14C / 8F	160		171,7 <i>109,6</i>	161,5 <i>116,2</i>	153,4 <i>126,0</i>	144,9 <i>136,9</i>	133,6 <i>146,9</i>	117,8 <i>154,0</i>	94,1 <i>156,7</i>	60,4 <i>152,8</i>		

MOTOR		Axis line	Drive unit	Base	Flange discharge	Foot valve	Strainer
kW	Gr. / Size						
11 - 15	160	LA 10/30	E 3/10	B 10/10	DN 250 - PN 25	VF9	SU9
18,5 - 22	180	LA 10/30	E 4/10				
30	200	LA 10/30	E 5/10				
37 - 45	225	LA 10/30	E 6/10				
55	250	LA 10/35	E 7/10				
75	280	LA 10/35	E 7/10				
90	280	LA 10/40	E 7/10				
110	315	LA 10/40	E 8/10				
132 - 160	315	LA 10/45	E 8/10				
200	315	LA 10/50	E 8/10				



VP 14C 1.480 rpm

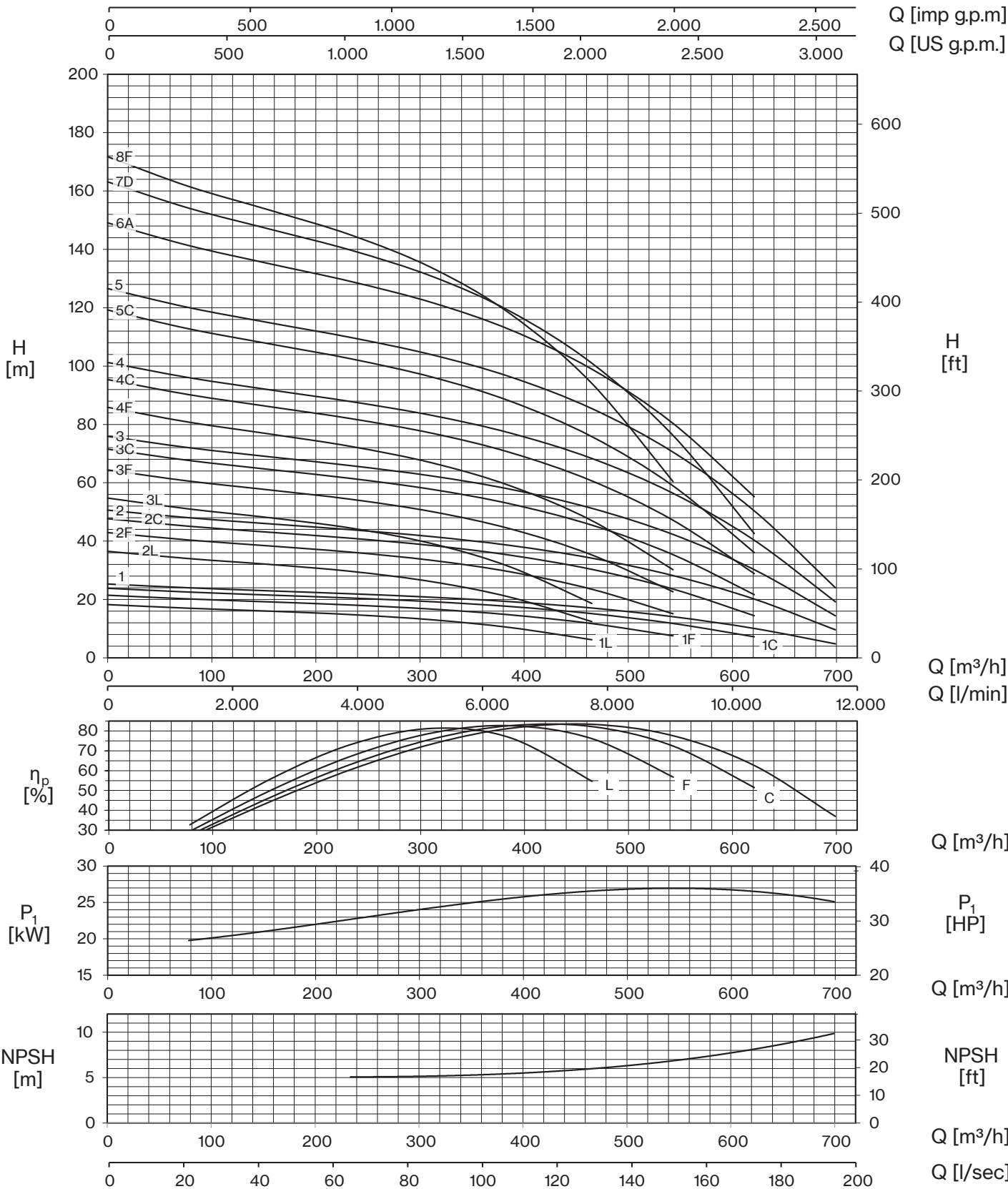

Valid for: ρ=1 (kg/dm³), viscosity ≤20 mm²/sec - Guarantee values according to ISO 9906, Grade 2 - Head based on SG=1





COMPONENTS CODES AND SPARE PARTS

Pump body VP 6/8/10/12/14/16/22

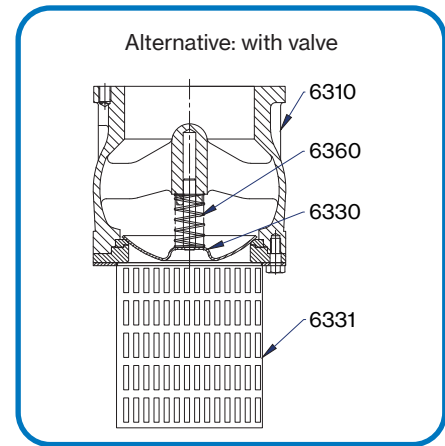
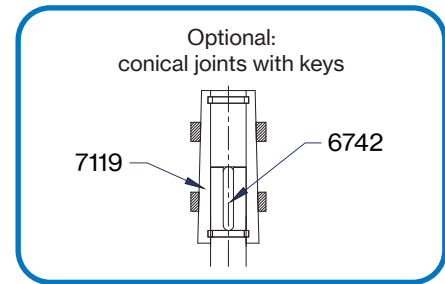
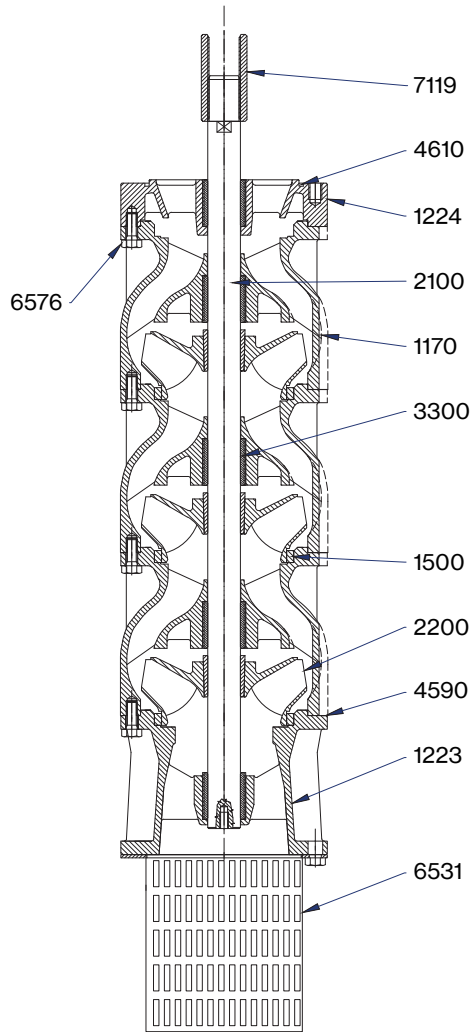

Ref.	Component	Materials	Recomanded spare part	Q.ty
1170	Diffuser	EN (G G25) - ASTM (A48 : Nr. 35)		
1223	Suction support	EN (G G25) - ASTM (A48 : Nr. 35)		
1224	Discharge Casing	EN (G G25) - ASTM (A48 : Nr. 35)		
1500	Wear rings	Gomma / Rubber	Yes	N
2100	Shaft	EN (X 30 Cr13) ASTM (420)	Yes	1
2200	Impeller	EN (G G25) - ASTM (A48 : Nr. 35)		
3300	Bearing	Rubber	Yes	N
6310	Valve body	-		
6330	Valve	-		
6531	Strainer	EN (X5CrNi1810) ASTM (304)		
4590	Gasket	Carta / Paper	Yes	N+1
4610	OR - Ring	NBR	Yes	N+1
6576	Screw	A2 - A4 if not specified		
6360	Spring	-		
6742	Key	A2 - A4 if not specified		
7119	Coupling	EN (X 30 Cr13) ASTM (420)		

N = stages number



Pump body VP 8RN/10R

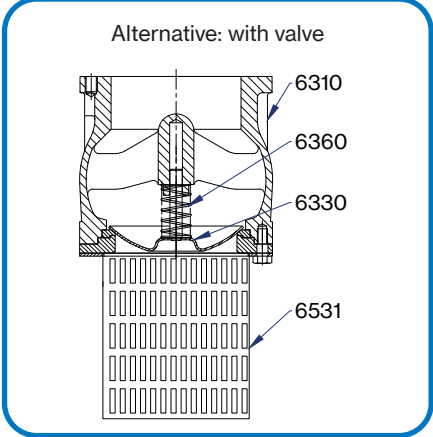
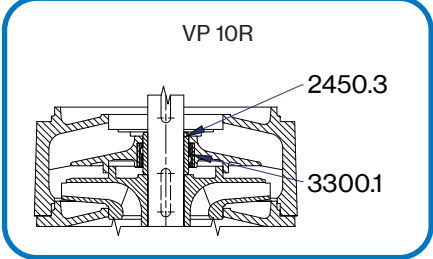
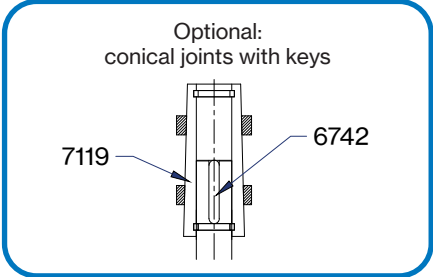
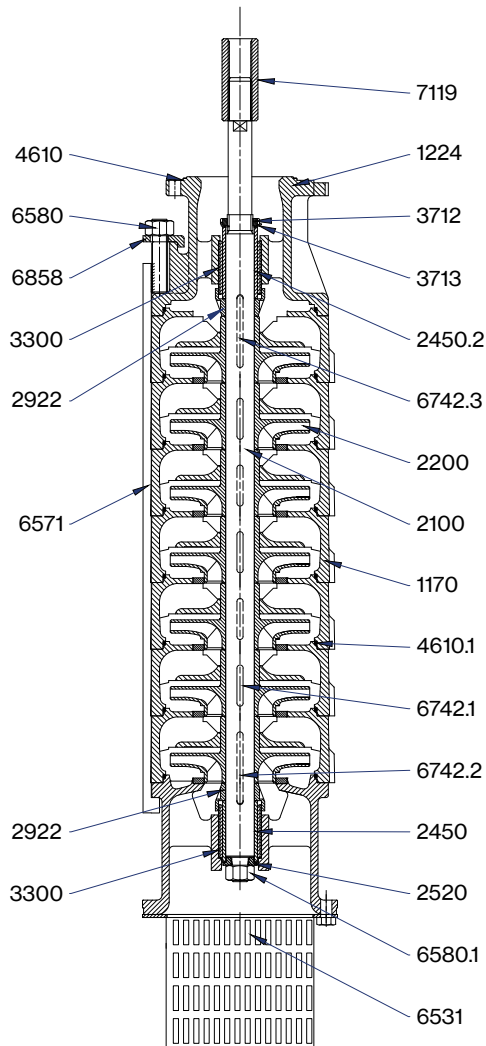

Ref.	Component	Materials	Recomanded spare part	Q.ty
1170	Diffuser	EN (G G25) - ASTM (A48 : Nr. 35)		
1223	Suction support	EN (G G25) - ASTM (A48 : Nr. 35)		
1224	Discharge Casing	EN (G G25) - ASTM (A48 : Nr. 35)		
2100	Shaft	EN (X 30 Cr13) ASTM (420)		
2200	Impeller	EN (G G25) - ASTM (A48 : Nr. 35)	Yes	N
2450	Shaft Sleeve	-	Yes	1
2450.2	Shaft Sleeve	-	Yes	1
2450.3	Shaft Sleeve	-	Yes if present	1
2520	Washer	EN (X 30 Cr13) ASTM (420)		
2922	Sandguard	Noryl	Yes	2+2
3300	Bearing	Rubber	Yes	2
3300.1	Bearing	Rubber	Yes	N
3712	Nut	Steel		
3713	Lockwasher	Steel		
4610	OR - Ring	NBR	Yes	N+1
6310	Valve body	-		
6330	Valve	-		
6360	Spring	-		
6531	Strainer	EN (X5CrNi1810) ASTM (304)		
6571	Tie bolt	Acciaio / Steel		
6580	Nut	A2 - A4 if not specified		
6580.1	Nut	A2 - A4 if not specified	Yes	1
6742	Key	A2 - A4 if not specified	Yes	1
6742.1	Key	A2 - A4 if not specified	Yes	N
6742.2	Key	A2 - A4 if not specified	Yes	1
6742.3	Key	A2 - A4 if not specified	Yes	1
6858	Plaque	Steel		

N = stages number



Axis line

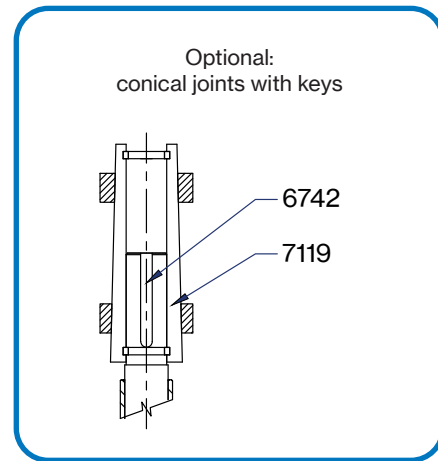
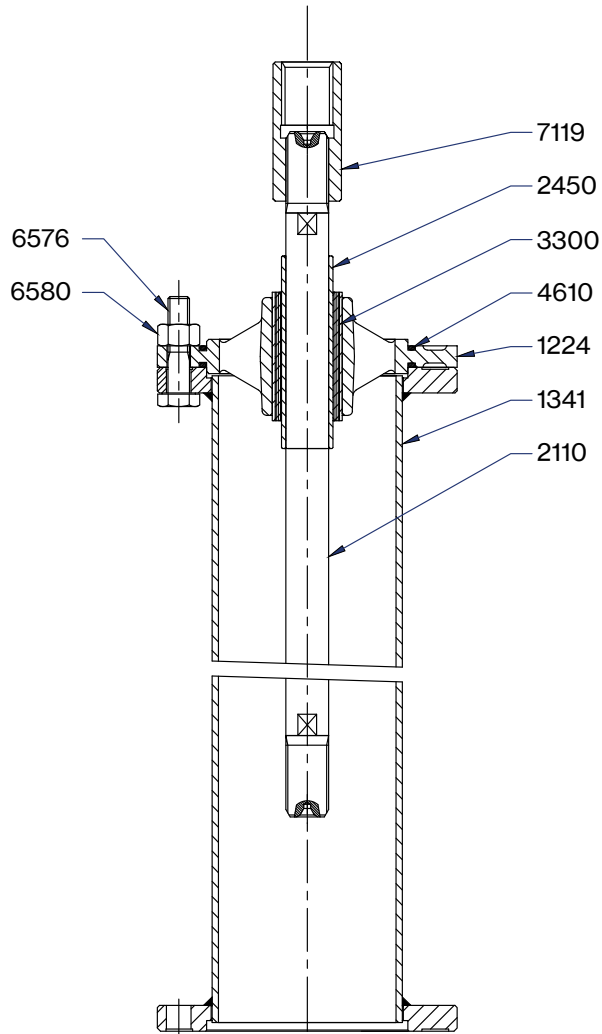

Ref.	Component	Materials	Recomanded spare part	Q.ty
1224	Support	EN (G G25) - ASTM (A48 : Nr. 35)		
1341	Pipe	EN (P235TR1) - ASTM (A 53 Grade A)		
2110	Shaft	C45E EN (Ck45) ASTM (1045)		
2450	Shaft Sleeve	$\varnothing \leq 30$ mm Brass $\varnothing > 30$ mm EN (X 30 Cr13) ASTM (420)	Yes	1
3300	Bearing	Rubber	Yes	1
4610	OR - Ring	NBR	Yes	1
6576	Screw	A2 - A4 if not specified		
6580	Nut	A2 - A4 if not specified		
6742	Key	A2 - A4 if not specified		
7119	Coupling	C45E EN (Ck45) ASTM (1045)		



Motor drive grease type

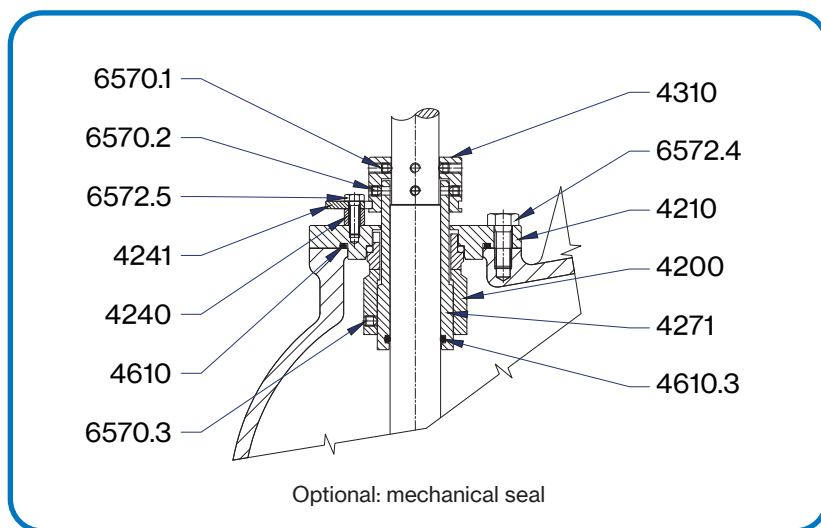
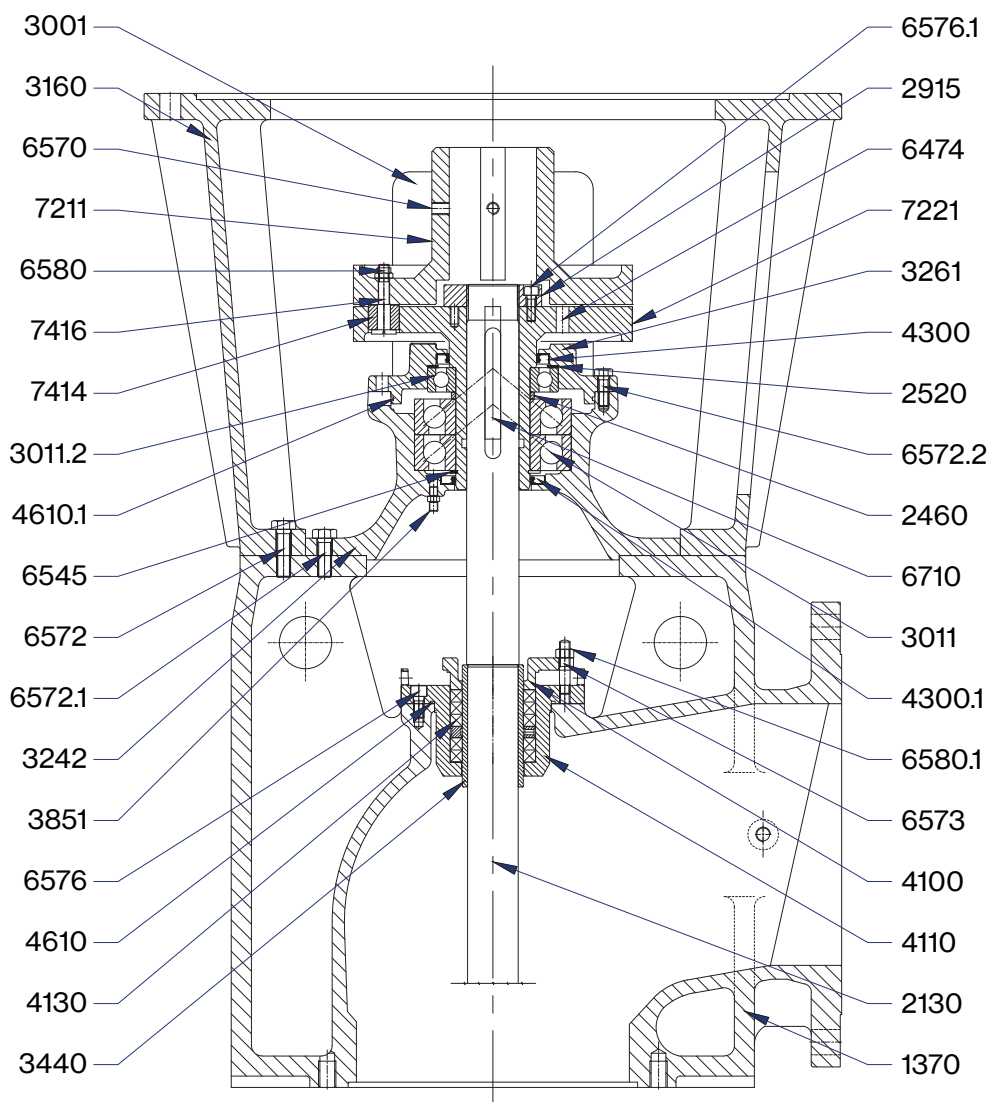

MOTOR DRIVE GREASE TYPE

Ref.	Component	Materials	Recomanded spare part	Q.ty
1370	Motor drive	EN (G GG42) ASTM (A536 : Gr. 65-A5-12)		
2130	Shaft	EN (X 30 Cr13) ASTM (420)		
2460	Space ring	Steel		
2520	Shoulder ring	Steel		
2915	Adjusting nut	Steel		
3001	Safety net	Steel		
3011	Bearing	-	Yes	2
3011.2	Bearing	-	Yes	1
3160	Electric motor support	EN (G GG42) ASTM (A536 : Gr. 65-A5-12)		
3242	Bearing housing	EN (G G25) - ASTM (A48 : Nr. 35)		
3261	Bearing cover	EN (G G25) - ASTM (A48 : Nr. 35)		
3440	Shaft Sleeve	EN (X 30 Cr13) ASTM (420)	Yes	1
3851	Grease cup	Steel		
4100	Stuffing box	EN (G GG42) ASTM (A536 : Gr. 65-A5-12)		
4110	Stuffing box housing	EN (G GG42) ASTM (A536 : Gr. 65-A5-12)		
4130	Gland packing	Cotton-graphite	Yes	1
4300	Radial shaft seal	NBR	Yes	1
4300.1	Radial shaft seal	NBR	Yes	1
4610	OR - Ring	Paper	Yes	1
6474	Pin	Steel	Yes	2/4/6
6545	Lock ring	Steel	Yes	1
6570	Screw	A2 - A4: if not specified		
6572	Screw	A2 - A4: if not specified		
6572.1	Screw	A2 - A4: if not specified		
6572.2	Screw	A2 - A4: if not specified		
6573	Stud bolt	A2 - A4: if not specified		
6576	Screw	A2 - A4: if not specified		
6576.1	Screw	A2 - A4: if not specified		
6580	Nut	A2 - A4: if not specified	Yes	4/6/8/10
6580.1	Nut	A2 - A4: if not specified		
6710	Key	A2 - A4: if not specified	Yes	1
7211	Motor coupling	EN (G G25) - ASTM (A48 : Nr. 35)		
7221	Pump coupling	EN (G G25) - ASTM (A48 : Nr. 35)		
7414	Coupling bush	Rubber	Yes	4/6/8/10
7416	Coupling bolt	A2 - A4: if not specified	Yes	4/6/8/10
4200	Mechanical seal	-	Yes	1
4210	Flange mechanical seal	Steel		
4240	Spacer	Steel		
4241	Washer	A2 - A4: if not specified		
4271	Shaft sleeve mechanical seal	Steel		
4310	Drive sleeve	Steel		
4610.3	OR - Ring	Paper	Yes	1
-	Washer Ring	Rubber	Yes	1
6570.1	Screw	A2 - A4: if not specified		
6570.2	Screw	A2 - A4: if not specified		
6570.3	Screw	A2 - A4: if not specified		
6572.4	Screw	A2 - A4: if not specified		
6572.5	Screw	A2 - A4: if not specified		



Motor drive oil type

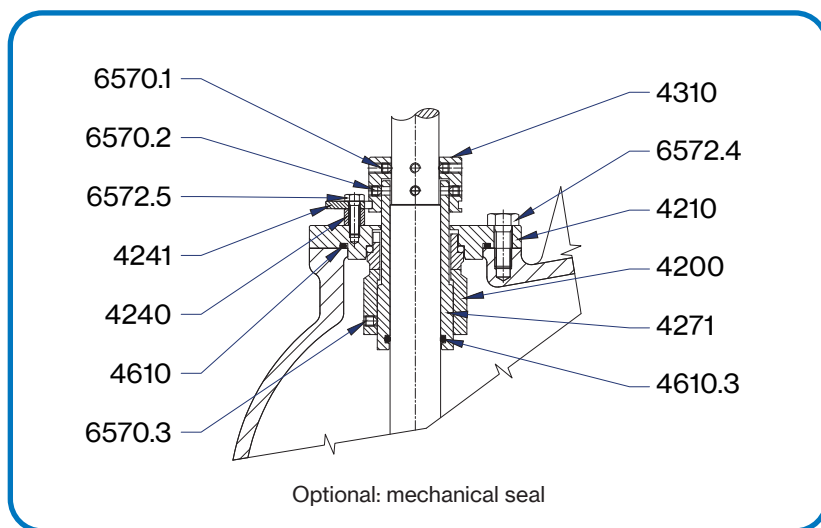
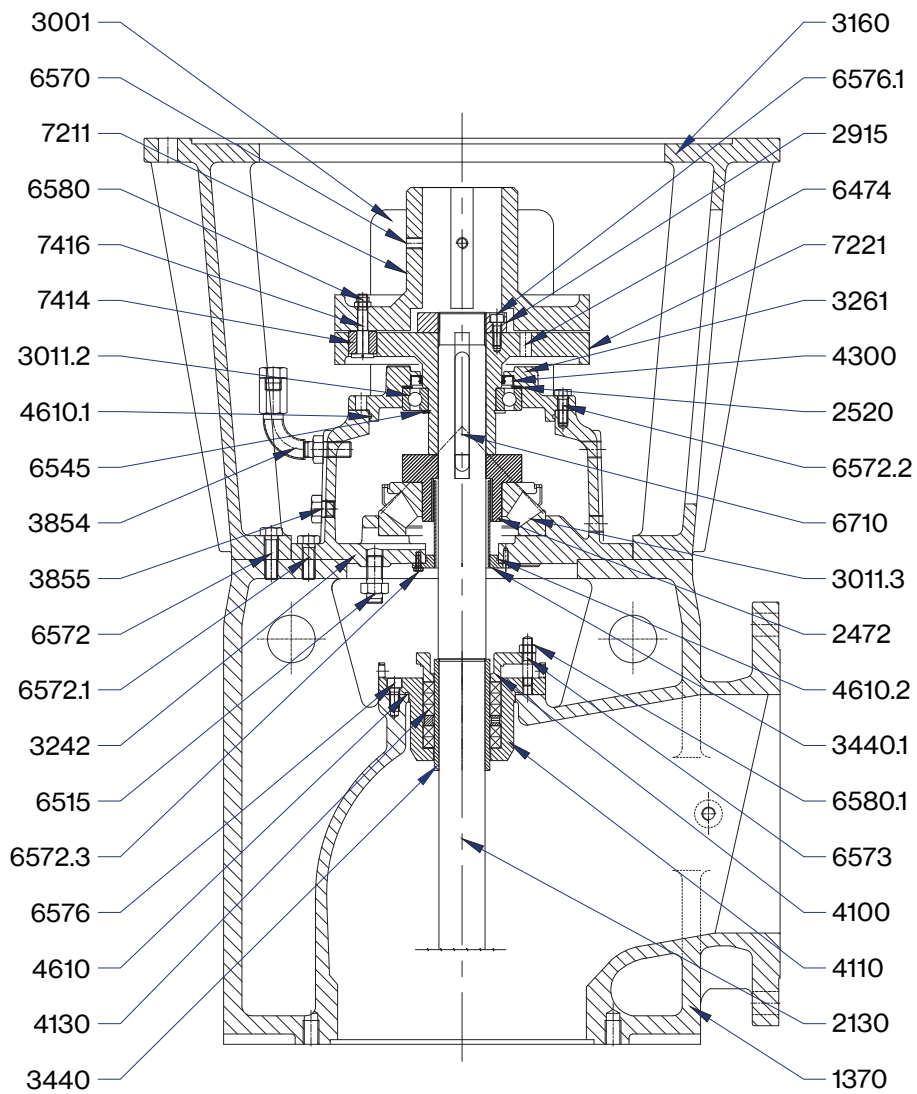

MOTOR DRIVE OIL TYPE

Ref.	Component	Materials	Recomanded spare part	Q.ty
1370	Motor drive	EN (G GG42) ASTM (A536 : Gr. 65-A5-12)		
2130	Shaft	EN (X 30 Cr13) ASTM (420)		
2472	Shaft sleeve bearing	Steel	Yes	1
2520	Shoulder ring	Steel	Yes	1
2915	Adjusting nut	Steel		
3001	Safety net	Steel		
3011.2	Bearing	-	Yes	1
3011.3	Bearing	-	Yes	1
3160	Electric motor support	EN (G GG42) ASTM (A536 : Gr. 65-A5-12)		
3242	Bearing housing	EN (G G25) - ASTM (A48 : Nr. 35)		
3261	Bearing cover	EN (G G25) - ASTM (A48 : Nr. 35)		
3440	Shaft Sleeve	EN (X 30 Cr13) ASTM (420)	Yes	1
3440.1	Oil glass	Steel	Yes	1
3854	Oil filling plug	Plastic		
3855	Oil indicator	Plastic-Steel		
4100	Stuffing box	EN (G GG42) ASTM (A536 : Gr. 65-A5-12)		
4110	Stuffing box housing	EN (G GG42) ASTM (A536 : Gr. 65-A5-12)		
4130	Gland packing	Cotton-graphite	Yes	1
4300	Radial shaft seal	NBR	Yes	1
4610	OR - Ring	Paper	Yes	1
4610.1	OR - Ring	NBR	Yes	1
4610.2	OR - Ring	NBR	Yes	1
6474	Pin	Steel	Yes	8/10
6515	Discharge plug	Steel		
6545	Lock ring	Steel		
6570	Screw	A2 - A4: if not specified		
6572	Screw	A2 - A4: if not specified		
6572.1	Screw	A2 - A4: if not specified		
6572.2	Screw	A2 - A4: if not specified		
6572.3	Screw	A2 - A4: if not specified		
6573	Stud bolt	A2 - A4: if not specified		
6576	Screw	A2 - A4: if not specified		
6576.1	Screw	A2 - A4: if not specified		
6580	Nut	A2 - A4: if not specified		
6580.1	Nut	A2 - A4: if not specified		
6710	Key	A2 - A4: if not specified		
7211	Motor coupling	EN (G G25) - ASTM (A48 : Nr.35)		
7221	Pump coupling	EN (G G25) - ASTM (A48 : Nr.35)		
7414	Coupling bush	Rubber	Yes	4/6/8/10
7416	Coupling bolt	A2 - A4: if not specified	Yes	4/6/8/10
4200	Mech. seal	Paper	Yes	1
4210	Flange mech. seal	Steel		
4240	Spacer	Steel		
4241	Washer	Steel		
4271	Shaft sleeve mechanical seal	Steel		
4310	Drive sleeve	Steel		
4610.3	OR - Ring	Paper	Yes	1
-	Washer Ring	Rubber	Yes	1
6570.1	Screw	A2 - A4: if not specified		
6570.2	Screw	A2 - A4: if not specified		
6570.3	Screw	A2 - A4: if not specified		
6572.4	Screw	A2 - A4: if not specified		
6572.5	Screw	A2 - A4: if not specified		



Overall dimensions

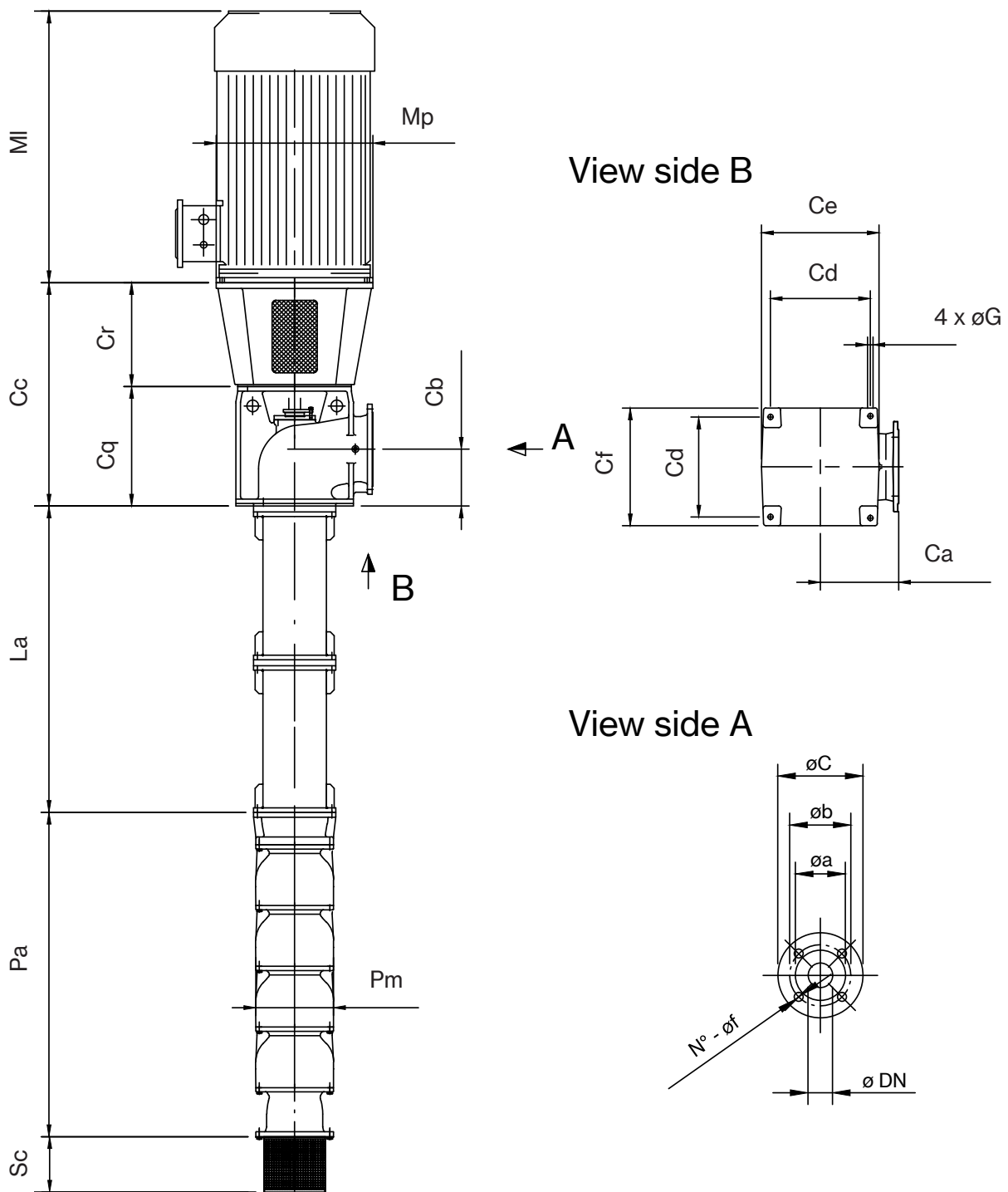

Flanges dimensions						
DN	PN	a	b	C	N°	$\varnothing f$
		mm				mm
100	25	156	190	235	8	22
150	25	211	250	300	8	28
200	25	274	310	360	12	28
250	25	330	370	425	12	30
300	25	389	430	485	16	30



Pump unit dimensions

VPL 6 3.000 rpm				[A-B-C-D-E]
TYPE	Pa	Pm	Sc	Kg
VPL 6... / 1	242	144	163	13
VPL 6... / 2	334	144	163	18,5
VPL 6... / 3	426	144	163	24
VPL 6... / 4	518	144	163	29,5
VPL 6... / 5	610	144	163	35
VPL 6... / 6	702	144	163	40,5
VPL 6... / 7	794	144	163	46
VPL 6... / 8	886	144	163	51,5
VPL 6... / 9	978	144	163	57
VPL 6... / 10	1070	144	163	62,5
VPL 6... / 11	1162	144	163	68
VPL 6... / 12	1254	144	163	73,5
VPL 6... / 13	1346	144	163	79
VPL 6... / 14	1438	144	163	84,5
VPL 6... / 15	1530	144	163	90
VPL 6... / 16	1622	144	163	95,5

VPL 8 1.500 / 3.000 rpm	[B-C]		[D-E-F]		[B-C-D-E-F]	
TYPE	Pa	Pm	Pa	Pm	Sc	Kg
VPL 8... / 1	298	187	318	190	163	30
VPL 8... / 2	428	187	468	190	163	43
VPL 8... / 3	558	187	618	190	163	56
VPL 8... / 4	688	187	768	190	163	69
VPL 8... / 5	818	187	918	190	163	82
VPL 8... / 6	948	187	1068	190	163	95
VPL 8... / 7	1078	187	1218	190	163	108
VPL 8... / 8	1208	187	1368	190	163	121
VPL 8... / 9	1338	187	1518	190	163	134
VPL 8... / 10	1468	187	1668	190	163	147
VPL 8... / 11	1598	187	1818	190	163	160
VPL 8... / 12	1728	187	1968	190	163	173
VPL 8... / 13	1858	187	2118	190	163	186
VPL 8... / 14	1988	187	2268	190	163	199
VPL 8... / 15	2118	187	2418	190	163	212
VPL 8... / 16	2248	187	2568	190	163	225
VPL 8... / 17	2378	187	2718	190	163	238
VPL 8... / 18	2508	187	2868	190	163	251

VPL 10 1.500 / 3.000 rpm				[A-B-C-D]
TYPE	Pa	Pm	Sc	Kg
VPL 10... / 1	435	245	230	52
VPL 10... / 2	620	245	230	78
VPL 10... / 3	805	245	230	104
VPL 10... / 4	990	245	230	130
VPL 10... / 5	1175	245	230	156
VPL 10... / 6	1360	245	230	182
VPL 10... / 7	1545	245	230	208
VPL 10... / 8	1730	245	230	234
VPL 10... / 9	1915	245	230	260
VPL 10... / 10	2100	245	230	286
VPL 10... / 11	2285	245	230	312
VPL 10... / 12	2470	245	230	338
VPL 10... / 13	2655	245	230	364

VP 12 1.500 / 3.000 rpm				[A-B-C]
TYPE	Pa	Pm	Sc	Kg
VP 12... / 1	530	295	254	89
VP 12... / 2	760	295	254	134
VP 12... / 3	990	295	254	179
VP 12... / 4	1220	295	254	224
VP 12... / 5	1450	295	254	269
VP 12... / 6	1680	295	254	314
VP 12... / 7	1910	295	254	359
VP 12... / 8	2140	295	254	404
VP 12... / 9	2370	295	254	449
VP 12... / 10	2600	295	254	494
VP 12... / 11	2830	295	254	539



PUMP UNIT DIMENSIONS

VP 14 1.500 rpm					[A-B-C]
TYPE	Pa	Pm	Sc	Kg	
VP 14... / 1	640	346	250	143	
VP 14... / 2	910	346	250	215	
VP 14... / 3	1180	346	250	287	
VP 14... / 4	1450	346	250	359	
VP 14... / 5	1720	346	250	431	
VP 14... / 6	1990	346	250	503	
VP 14... / 7	2260	346	250	575	
VP 14... / 8	2530	346	250	647	
VP 14... / 9	2800	346	250	719	
VP 14... / 10	3070	346	250	791	

VP 16 1.500 rpm		[A-B-C]			[D]			[A-B-C-D]
TYPE	Pa	Pm	Kg	Pa	Pm	Kg	Sc	
VP 16... / 1	725	396	198	765	415	215	282	
VP 16... / 2	1035	396	306	1135	415	334	282	
VP 16... / 3	1345	396	414	1505	415	453	282	
VP 16... / 4	1655	396	522	1875	415	572	282	
VP 16... / 5	1965	396	630	2245	415	691	282	
VP 16... / 6	2275	396	738	2615	415	810	282	
VP 16... / 7	2585	396	846	2985	415	929	282	
VP 16... / 8	2895	396	954	3355	415	1048	282	
VP 16... / 9	3205	396	1062	3725	415	1167	282	
VP 16... / 10	3515	396	1170	4095	415	1286	282	

VPL 8RN 3.000 rpm					[B-C]
TYPE	Pa	Pm	Sc	Kg	
VPL 8RN... / 1	325	185	163	36	
VPL 8RN... / 2	390	185	163	41	
VPL 8RN... / 3	455	185	163	46	
VPL 8RN... / 4	520	185	163	51	
VPL 8RN... / 5	585	185	163	56	
VPL 8RN... / 6	650	185	163	61	
VPL 8RN... / 7	715	185	163	66	
VPL 8RN... / 8	780	185	163	71	
VPL 8RN... / 9	845	185	163	76	
VPL 8RN... / 10	910	185	163	81	
VPL 8RN... / 11	975	185	163	86	
VPL 8RN... / 12	1040	185	163	91	
VPL 8RN... / 13	1105	185	163	96	
VPL 8RN... / 14	1170	185	163	101	
VPL 8RN... / 15	1235	185	163	106	
VPL 8RN... / 16	1300	185	163	111	
VPL 8RN... / 17	1365	185	163	116	
VPL 8RN... / 18	1430	185	163	121	

VPL 10R 3.000 rpm					[A-B-C]
TYPE	Pa	Pm	Sc	Kg	
VPL 10R... / 1	388	230	230	83	
VPL 10R... / 2	466	230	230	94	
VPL 10R... / 3	544	230	230	105	
VPL 10R... / 4	622	230	230	116	
VPL 10R... / 5	700	230	230	127	
VPL 10R... / 6	778	230	230	138	
VPL 10R... / 7	856	230	230	149	
VPL 10R... / 8	934	230	230	160	
VPL 10R... / 9	1012	230	230	171	
VPL 10R... / 10	1090	230	230	182	
VPL 10R... / 11	1168	230	230	193	
VPL 10R... / 12	1246	230	230	204	

VP 22 950 / 1500 rpm				
TYPE	Pa	Pm	Sc	Kg
VP 22-400 / 1	1112	545	480	366
VP 22-400 / 2	1462	545	480	561
VP 22-400 / 3	1812	545	480	756
VP 22-400 / 4	2162	545	480	951
VP 22-400 / 5	2512	545	480	1146



Overall dimensions for the axis line, drive head and electric motor 1.500 rpm

Motor		Drive Delivery Head Unit													Motor		Weight Kg		
kW	Size	Type	Lenght L a	Type	Flange DN	C a	C b	C c	C d	C e	C f	C g	C q	C r	MI	Mp	Axis line	Drive unit	Motor
1,5	90	LA 3	3050	E 0/3	100	220	130	510	265	320	320	18	310	200	340	250	36	73,5	29
		LA 4	3050	E 0/4	100	220	130	510	265	320	320	18	310	200	340	250	46	73,5	29
2,2 - 3 - 4	100-112	LA 3	3050	E 1/3	100	220	130	510	265	320	320	18	310	200	375 - 400	250	36	73,5	35 - 45
		LA 4	3050	E 1/4	100	220	130	510	265	320	320	18	310	200	375 - 400	250	46	73,5	35 - 45
		LA 5	3050	E 1/5	150	280	180	620	345	425	415	21	420	200	375 - 400	250	64	117,5	35 - 45
		LA 6	3050	E 1/6	150	280	180	620	345	425	415	21	420	200	375 - 400	250	85	117,5	35 - 45
5,5 - 7,5	132	LA 3	3050	E 2/3	100	220	130	510	265	320	320	18	310	200	465 - 505	300	36	87	62 - 74
		LA 4	3050	E 2/4	100	220	130	510	265	320	320	18	310	200	465 - 505	300	46	87	62 - 74
		LA 5	3050	E 2/5	150	280	180	620	345	425	415	21	420	200	465 - 505	300	64	131	62 - 74
		LA 6	3050	E 2/6	150	280	180	620	345	425	415	21	420	200	465 - 505	300	85	131	62 - 74
		LA 8	3000	E 2/8	200	300	200	675	400	480	470	23	475	200	465 - 505	300	140	176	62 - 74
11 - 15	160	LA 3	3050	E 3/3	100	220	130	562	265	320	320	18	310	252	608 - 652	350	36	103	115 - 135
		LA 4	3050	E 3/4	100	220	130	562	265	320	320	18	310	252	608 - 652	350	46	103	115 - 135
		LA 5	3050	E 3/5	150	280	180	672	345	425	415	21	420	252	608 - 652	350	64	147	115 - 135
		LA 6	3050	E 3/6	150	280	180	672	345	425	415	21	420	252	608 - 652	350	85	147	115 - 135
		LA 8	3000	E 3/8	200	300	200	727	400	480	470	23	475	252	608 - 652	350	140	192	115 - 135
		LA 10	3000	E 3/10	250	400	250	802	550	620	620	30	550	252	608 - 652	350	189	316	115 - 135
18,5 - 22	180	LA 4	3050	E 4/4	100	220	130	562	265	320	320	18	310	252	690 - 730	350	46	103	170 - 184
		LA 5	3050	E 4/5	150	280	180	672	345	425	415	21	420	252	690 - 730	350	64	147	170 - 184
		LA 6	3050	E 4/6	150	280	180	672	345	425	415	21	420	252	690 - 730	350	85	147	170 - 184
		LA 8	3000	E 4/8	200	300	200	727	400	480	470	23	475	252	690 - 730	350	140	192	170 - 184
		LA 10	3000	E 4/10	250	400	250	802	550	620	620	30	550	252	690 - 730	350	189	316	170 - 184
30	200	LA 4	3050	E 5/4	100	220	130	610	265	320	320	18	310	300	760	400	46	125	235
		LA 5	3050	E 5/5	150	280	180	720	345	425	415	21	420	300	760	400	64	169	235
		LA 6	3050	E 5/6	150	280	180	720	345	425	415	21	420	300	760	400	85	169	235
		LA 8	3000	E 5/8	200	300	200	775	400	480	470	23	475	300	760	400	140	214	235
		LA 10	3000	E 5/10	250	400	250	850	550	620	620	30	550	300	760	400	189	338	235
37 - 45	225	LA 4	3050	E 6/4	100	220	130	610	265	320	320	18	310	300	810 - 835	450	46	125	290 - 326
		LA 5	3050	E 6/5	150	280	180	720	345	425	415	21	420	300	810 - 835	450	64	169	290 - 326
		LA 6	3050	E 6/6	150	280	180	720	345	425	415	21	420	300	810 - 835	450	85	169	290 - 326
		LA 8	3000	E 6/8	200	300	200	775	400	480	470	23	475	300	810 - 835	450	140	214	290 - 326
		LA 10	3000	E 6/10	250	400	250	850	550	620	620	30	550	300	810 - 835	450	189	338	290 - 326
		LA 12	2500	E 6/12	300	400	290	910	510	600	600	28	610	300	810 - 835	450	277	384	290 - 326
55 75 - 90	250 280	LA 5	3050	E 7/5	150	280	180	752	345	425	415	21	420	332	910 - 1060	550	64	218	385 - 605
		LA 6	3050	E 7/6	150	280	180	752	345	425	415	21	420	332	910 - 1060	550	85	218	385 - 605
		LA 8	3000	E 7/8	200	300	200	807	400	480	470	23	475	332	910 - 1060	550	140	263	385 - 605
		LA 10	3000	E 7/10	250	400	250	882	550	620	620	30	550	332	910 - 1060	550	189	387	385 - 605
		LA 12	2500	E 7/12	300	400	290	942	510	600	600	28	610	332	910 - 1060	550	277	433	385 - 605
110 - 132 160 - 200	315	LA 6	3050	E 8/6	150	280	180	752	345	425	415	21	420	332	1210 - 1320	660	85	238	931 - 1200
		LA 8	3000	E 8/8	200	300	200	807	400	480	470	23	475	332	1210 - 1320	660	140	283	931 - 1200
		LA 10	3000	E 8/10	250	400	250	882	550	620	620	30	550	332	1210 - 1320	660	189	407	931 - 1200
		LA 12	2500	E 8/12	300	400	290	942	510	600	600	28	610	332	1210 - 1320	660	277	453	931 - 1200
		LA 14	2500	E 8/14	400	510	370	1127	650	800	800	37	795	332	1210 - 1320	660	365	715	931 - 1200
250 - 280 315	355	LA 10	3000	E 9/10	250	400	250	1080	550	620	620	30	550	530	1596 - 1596	800	189	598	1740 - 1975
		LA 12	2500	E 9/12	300	400	290	1140	510	600	600	28	610	530	1596 - 1596	800	277	644	1740 - 1975
		LA 14	2500	E 9/14	400	510	370	1325	650	800	800	37	795	530	1596 - 1596	800	365	906	1740 - 1975
355 - 375	400	LA 14	2500	E 10/14	400	510	370	1325	650	800	800	37	795	530	1925 - 1925	1000	365	1050	2930 - 2980

All data in mm



Overall dimensions for the axis line, drive head and electric motor 3.000 rpm

Motor		Drive Delivery Head Unit													Motor		Weight Kg		
kW	Size	Type	Length L _a	Type	Flange DN	C a	C b	C c	C d	C e	C f	C g	C q	C r	Ml	Mp	Axis line	Drive unit	Motor
1,5 - 2,2	90	LA 3	3050	E 0/3	100	220	130	510	265	320	320	18	310	200	315 - 340	200 - 250	36	73,5	23 - 26
		LA 4	3050	E 0/4	100	220	130	510	265	320	320	18	310	200	315 - 340	200 - 250	46	73,5	23 - 26
3 - 4	100-112	LA 3	3050	E 1/3	100	220	130	510	265	320	320	18	310	200	375 - 400	250	36	73,5	34 - 41
		LA 4	3050	E 1/4	100	220	130	510	265	320	320	18	310	200	375 - 400	250	46	73,5	34 - 41
		LA 5	3050	E 1/5	150	280	180	620	345	425	415	21	420	200	375 - 400	250	64	117,5	34 - 41
		LA 6	3050	E 1/6	150	280	180	620	345	425	415	21	420	200	375 - 400	250	85	117,5	34 - 41
5,5 - 7,5	132	LA 3	3050	E 2/3	100	220	130	510	265	320	320	18	310	200	465 - 465	300	36	87	60 - 63
		LA 4	3050	E 2/4	100	220	130	510	265	320	320	18	310	200	465 - 465	300	46	87	60 - 63
		LA 5	3050	E 2/5	150	280	180	620	345	425	415	21	420	200	465 - 465	300	64	131	60 - 63
		LA 6	3050	E 2/6	150	280	180	620	345	425	415	21	420	200	465 - 465	300	85	131	60 - 63
		LA 8	3000	E 2/8	200	300	200	675	400	480	470	23	475	200	465 - 465	300	140	176	60 - 63
		LA 10	3000	E 2/10	250	400	250	750	550	620	620	30	550	200	465 - 465	300	189	300	60 - 63
11 - 15 18,5	160	LA 3	3050	E 3/3	100	220	130	562	265	320	320	18	310	252	608 - 652	350	36	103	109 - 136
		LA 4	3050	E 3/4	100	220	130	562	265	320	320	18	310	252	608 - 652	350	46	103	109 - 136
		LA 5	3050	E 3/5	150	280	180	672	345	425	415	21	420	252	608 - 652	350	64	147	109 - 136
		LA 6	3050	E 3/6	150	280	180	672	345	425	415	21	420	252	608 - 652	350	85	147	109 - 136
		LA 8	3000	E 3/8	200	300	200	727	400	480	470	23	475	252	608 - 652	350	140	192	109 - 136
		LA 10	3000	E 3/10	250	400	250	802	550	620	620	30	550	252	608 - 652	350	189	316	109 - 136
22	180	LA 4	3050	E 4/4	100	220	130	562	265	320	320	18	310	252	690	350	46	103	172
		LA 5	3050	E 4/5	150	280	180	672	345	425	415	21	420	252	690	350	64	147	172
		LA 6	3050	E 4/6	150	280	180	672	345	425	415	21	420	252	690	350	85	147	172
		LA 8	3000	E 4/8	200	300	200	727	400	480	470	23	475	252	690	350	140	192	172
		LA 10	3000	E 4/10	250	400	250	802	550	620	620	30	550	252	690	350	189	316	172
		LA 12	2500	E 4/12	300	400	290	862	510	600	600	28	610	252	690	350	277	362	172
30 - 37	200	LA 4	3050	E 5/4	100	220	130	610	265	320	320	18	310	300	760 - 760	400	46	125	223 - 242
		LA 5	3050	E 5/5	150	280	180	720	345	425	415	21	420	300	760 - 760	400	64	169	223 - 242
		LA 6	3050	E 5/6	150	280	180	720	345	425	415	21	420	300	760 - 760	400	85	169	223 - 242
		LA 8	3000	E 5/8	200	300	200	775	400	480	470	23	475	300	760 - 760	400	140	214	223 - 242
		LA 10	3000	E 5/10	250	400	250	850	550	620	620	30	550	300	760 - 760	400	189	338	223 - 242
		LA 12	2500	E 5/12	300	400	290	910	510	600	600	28	610	300	760 - 760	400	277	384	223 - 242
45	225	LA 4	3050	E 6/4	100	220	130	610	265	320	320	18	310	300	805	450	46	125	302
		LA 5	3050	E 6/5	150	280	180	720	345	425	415	21	420	300	805	450	64	169	302
		LA 6	3050	E 6/6	150	280	180	720	345	425	415	21	420	300	805	450	85	169	302
		LA 8	3000	E 6/8	200	300	200	775	400	480	470	23	475	300	805	450	140	214	302
		LA 10	3000	E 6/10	250	400	250	850	550	620	620	30	550	300	805	450	189	338	302
		LA 12	2500	E 6/12	300	400	290	910	510	600	600	28	610	300	805	450	277	384	302
55 75 - 90	250 280	LA 5	3050	E 7/5	150	280	180	752	345	425	415	21	420	332	910 - 1030	550	64	218	382 - 545
		LA 6	3050	E 7/6	150	280	180	752	345	425	415	21	420	332	910 - 1030	550	85	218	382 - 545
		LA 8	3000	E 7/8	200	300	200	807	400	480	470	23	475	332	910 - 1030	550	140	263	382 - 545
		LA 10	3000	E 7/10	250	400	250	882	550	620	620	30	550	332	910 - 1030	550	189	387	382 - 545
		LA 12	2500	E 7/12	300	400	290	942	510	600	600	28	610	332	910 - 1030	550	277	433	382 - 545
110 - 132 160 - 200	315	LA 6	3050	E 8/6	150	280	180	752	345	425	415	21	420	332	1180 - 1290	660	85	238	930 - 1190
		LA 8	3000	E 8/8	200	300	200	807	400	480	470	23	475	332	1180 - 1290	660	140	283	930 - 1190
		LA 10	3000	E 8/10	250	400	250	882	550	620	620	30	550	332	1180 - 1290	660	189	407	930 - 1190
		LA 12	2500	E 8/12	300	400	290	942	510	600	600	28	610	332	1180 - 1290	660	277	453	930 - 1190
		LA 14	2500	E 8/14	400	510	370	1127	650	800	800	37	795	332	1180 - 1290	660	365	715	930 - 1190
250 - 280 315	355	LA 10	3000	E 9/10	250	400	250	1080	550	620	620	30	550	530	1526 - 1526	800	189	598	1710 - 1920
		LA 12	2500	E 9/12	300	400	290	1140	510	600	600	28	610	530	1526 - 1526	800	277	644	1710 - 1920
		LA 14	2500	E 9/14	400	510	370	1325	650	800	800	37	795	530	1526 - 1526	800	365	906	1710 - 1920
355	400	LA 14	2500	E 10/14	400	510	370	1325	650	800	800	37	795	530	1526	800	365	1050	1975

All data in mm



Dimensions of the components

STRAINER

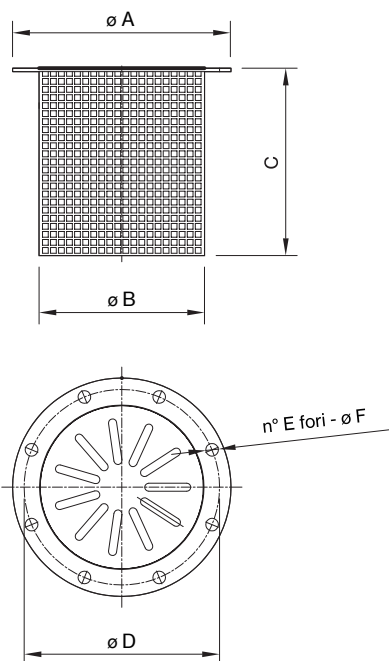

STRAINER	FOR PUMP	A	B	C	D	E	F	Kg
		mm				n°	mm	
SU3	VPL 6A	142	105	163	126	8	9	0,9
	VPL 6B	142	105	163	126	8	9	0,9
	VPL 6C	142	105	163	126	8	9	0,9
	VPL 6D	142	105	163	126	8	9	0,9
	VPL 6E	142	105	163	126	8	9	0,9
SU4	VPL 8B	170	129	163	154	8	9	1,1
	VPL 8C	170	129	163	154	8	9	1,1
	VPL 8RNB	170	129	163	154	8	9	1,1
SU5	VPL 8RNC	170	129	163	154	8	9	1,1
	VPL 8D	190	144	163	170	8	11	1,6
	VPL 8E	190	144	163	170	8	11	1,6
SU6	VPL 8F	190	144	163	170	8	11	1,6
	VPL 10A	240	161	230	208	6	16	2,8
	VPL 10B	240	161	230	208	6	16	2,8
SU8	VPL 10C	240	161	230	208	6	16	2,8
	VPL 10D	240	161	230	208	6	16	2,8
	VPL 10RA	240	161	230	208	6	16	2,8
SU9	VPL 10RB	240	161	230	208	6	16	2,8
	VPL 10RC	240	161	230	208	6	16	2,8
	VP 12A	295	235	254	260	8	14	3,7
SU10	VP 12B	295	235	254	260	8	14	3,7
	VP 12C	295	235	254	260	8	14	3,7
	VP 14A	338	270	250	310	12	16	4,2
SU11	VP 14B	338	270	250	310	12	16	4,2
	VP 14C	338	270	250	310	12	16	4,2
	VP 16A	396	315	282	360	12	18	6,5
SU12	VP 16B	396	315	282	360	12	18	6,5
	VP 16C	396	315	282	360	12	18	6,5
	VP 16D	465	352	282	420	6	18	8
	VP 22-400	600	520	480	565	12	22	9,7

FOOT VALVE

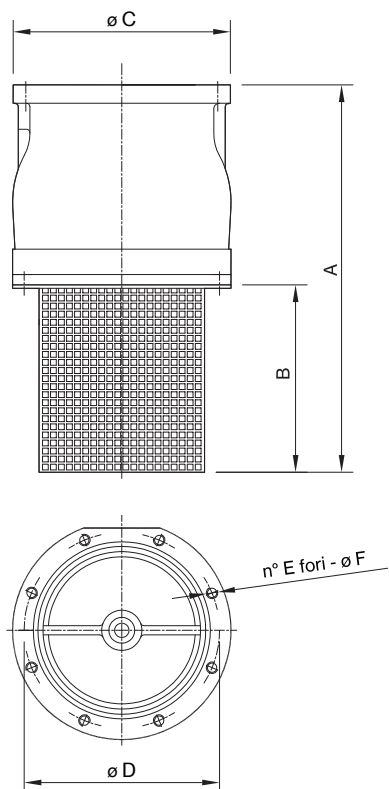

STRAINER	FOR PUMP	A	B	C	D	E	F	Kg
		mm				n°	mm	
VF3	VPL 6A	293	163	141	126	8	9	7,5
	VPL 6B	293	163	141	126	8	9	7,5
	VPL 6C	293	163	141	126	8	9	7,5
	VPL 6D	293	163	141	126	8	9	7,5
	VPL 6E	293	163	141	126	8	9	7,5
VF4	VPL 8B	306	166	169	145	6	11	9,4
	VPL 8C	306	166	169	145	6	11	9,4
	VPL 8RNB	306	166	169	145	6	11	9,4
VF5	VPL 8RNC	306	166	169	145	6	11	9,4
	VPL 8D	343	169	189	167	6	M 12	13
	VPL 8E	343	169	189	167	6	M 12	13
VF6	VPL 8F	343	169	189	167	6	M 12	13
	VPL 10A	465	245	235	208	6	16	22
	VPL 10B	465	245	235	208	6	16	22
VF8	VPL 10C	465	245	235	208	6	16	22
	VPL 10D	465	245	235	208	6	16	22
	VPL 10RA	465	245	235	208	6	16	22
VF9	VPL 10RB	465	245	235	208	6	16	22
	VPL 10RC	465	245	235	208	6	16	22
	VP 12A	512	254	295	260	8	14	42
VF11	VP 12B	512	254	295	260	8	14	42
	VP 12C	512	254	295	260	8	14	42
	VP 14A	545	250	346	310	12	18	82
VF12	VP 14B	545	250	346	310	12	18	82
	VP 14C	545	250	346	310	12	18	82
	VP 16D	-	-	-	-	-	-	-
	VP 22-400	-	-	-	-	-	-	-



Pump body overall dimensions and weight

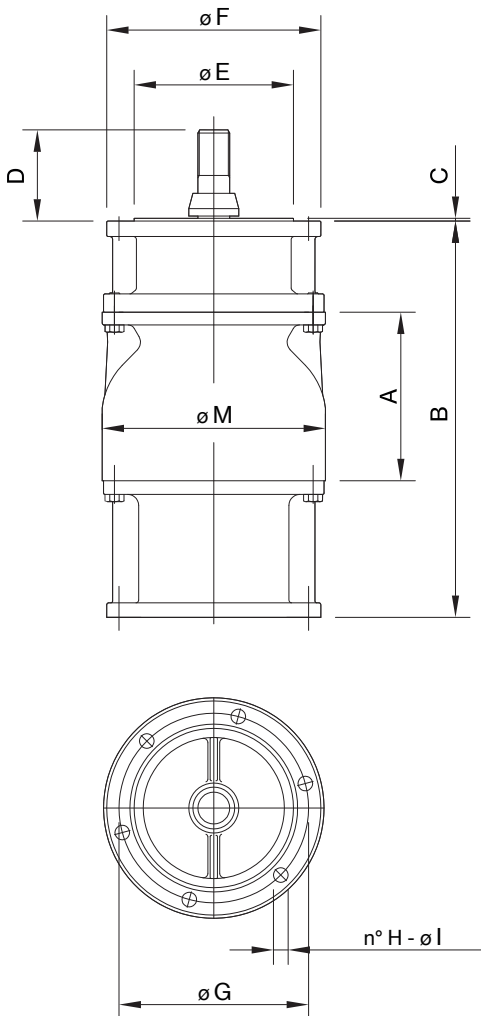

TYPE	TYPE AXIS LINE	WELL NOMINAL Ø	A	B	C	D	E	F	G	H	I	M	Y	Z	
			mm									n°	mm		Kg
VPL 6A	LA 3	6"	92	242	4	100	95	144	120	5	12	144	13	5	
VPL 6B			92	242	4	100	95	144	120	5	12	144	13	5	
VPL 6C			92	242	4	100	95	144	120	5	12	144	13	5	
VPL 6D			92	242	4	100	95	144	120	5	12	144	13	5	
VPL 6E			92	242	4	100	95	144	120	5	12	144	13	5	
VPL 8B	LA 3	8"	130	298	3	100	95	190	120	5	12	187	30	13	
VPL 8B			130	298	3	100	122	190	145	6	12	187	30	13	
VPL 8C	LA 4		130	298	3	100	122	190	145	6	12	187	30	13	
VPL 8D			150	318	3	100	122	190	145	6	12	190	30	13	
VPL 8E	LA 5		150	318	3	100	140	190	168	6	14	190	30	13	
VPL 8E ¹⁰⁰			150	318	3	100	140	190	168	6	14	190	30	13	
VPL 8F	LA 3		150	318	3	100	140	190	168	6	14	191	30	13	
VPL 8RNB			65	325	3	100	95	144	120	5	12	185	36	5	
VPL 8RNC			65	325	3	100	95	144	120	5	12	185	36	5	
VPL 10A	LA 5		10"	185	435	3	100	140	235	168	6	14	245	52	26
VPL 10B		185		435	3	100	140	235	168	6	14	245	52	26	
VPL 10A	LA 6	185		435	3	100	176	235	206	6	16	245	52	26	
VPL 10B		185		435	3	100	176	235	206	6	16	245	52	26	
VPL 10C		185		435	3	100	176	235	206	6	16	245	52	26	
VPL 10D	LA 8	185		435	3	100	176	235	206	6	16	245	52	26	
VPL 10D		185		435	3	120	228	235	265	8	18	245	52	26	
VPL 10RA	LA 3	78		388	3	100	95	205	120	5	12	230	83	11	
VPL 10RB		78		388	3	100	95	205	120	5	12	230	83	11	
VPL 10RC		78		388	3	100	95	205	120	5	12	230	83	11	
VP 12A	LA 6	12"	230	530	4	100	176	298	206	6	16	295	89	45	
VP 12B			230	530	4	100	176	298	206	6	16	295	89	45	
VP 12C	LA 8		230	530	4	100	176	298	206	6	16	295	89	45	
VP 12A			230	530	4	120	228	298	265	8	18	295	89	45	
VP 12B	LA 8		230	530	4	120	228	298	265	8	18	295	89	45	
VP 12C			230	530	4	120	228	298	265	8	18	295	89	45	
VP 14A	LA 6		14"	270	640	4	100	176	298	206	6	16	346	143	72
VP 14A				270	640	4	120	228	298	265	8	18	346	143	72
VP 14B	LA 8			270	640	4	120	228	298	265	8	18	346	143	72
VP 14C				270	640	4	120	228	298	265	8	18	346	143	72
VP 14B	LA 10	270		640	4	150	282	298	320	12	18	346	143	72	
VP 14C		270		640	4	150	282	298	320	12	18	346	143	72	
VP 16A	LA 8	16"		310	725	4	120	228	355	265	8	18	396	198	108
VP 16A				310	725	4	150	282	355	320	12	18	396	198	108
VP 16B	LA 10			310	725	4	120	228	355	265	8	18	396	198	108
VP 16C				310	725	4	150	282	355	320	12	18	396	198	108
VP 16C	LA 12		310	725	4	120	332	355	380	12	22	396	198	108	
VP 16D			370	765	4	150	332	355	380	12	22	415	215	119	
VP 22-400	LA 12		22"	350	1112	5	150	332	470	380	12	22	545	366	195
	LA 14			350	1112	5	170	365	470	425	12	22	545	366	195

B = is referred to 1 stage pump length

Y = Weight for 1 stage pump length

Z = Weight for each stage

$$\text{Pump weight} = Y + \left[\text{stage n.} - 1 \right] \cdot Z$$



Axis line overall dimensions and weight

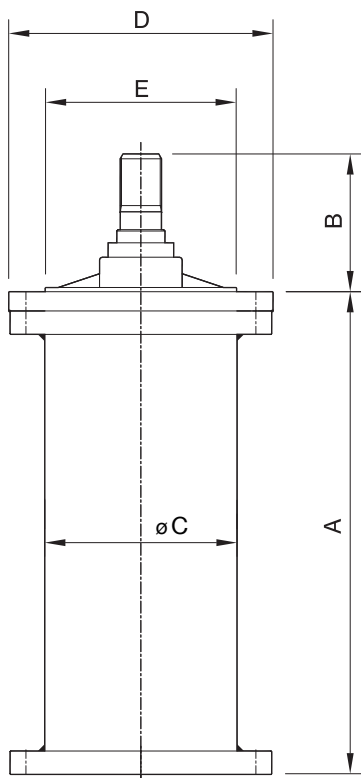

TYPE	A	B	C	D	E	F	G	H	Kg/1 m
	mm						n°	mm	
LA 3 / 20	3050	100	89	140	95	120	5	12	11,8
LA 3 / 24	3050	100	89	140	95	120	5	12	11,8
LA 4 / 20	3050	100	114	166	122	145	6	12	15,1
LA 4 / 24	3050	100	114	166	122	145	6	12	15,1
LA 4 / 30	3050	100	114	166	122	145	6	12	15,1
LA 5 / 20	3050	100	140	190	140	168	6	14	21
LA 5 / 24	3050	100	140	190	140	168	6	14	21
LA 5 / 30	3050	100	140	190	140	168	6	14	21
LA 6 / 24	3050	100	168	234	176	206	6	16	27,9
LA 6 / 30	3050	100	168	234	176	206	6	16	27,9
LA 6 / 35	3050	100	168	234	176	206	6	16	27,9
LA 8 / 30	3000	120	219	298	228	265	8	18	46,7
LA 8 / 35	3000	120	219	298	228	265	8	18	46,7
LA 8 / 40	3000	120	219	298	228	265	8	18	46,7
LA 8 / 45	3000	120	219	298	228	265	8	18	46,7
LA 10 / 30	3000	150	273	355	282	320	12	18	63
LA 10 / 35	3000	150	273	355	282	320	12	18	63
LA 10 / 40	3000	150	273	355	282	320	12	18	63
LA 10 / 45	3000	150	273	355	282	320	12	18	63
LA 10 / 50	3000	150	273	355	282	320	12	18	63
LA 12 / 35	2500	150	324	420	332	380	12	22	110,8
LA 12 / 40	2500	150	324	420	332	380	12	22	110,8
LA 12 / 45	2500	150	324	420	332	380	12	22	110,8
LA 12 / 50	2500	150	324	420	332	380	12	22	110,8
LA 12 / 60	2500	150	324	420	332	380	12	22	110,8
LA 12 / 70	2500	150	324	420	332	380	12	22	110,8
LA 14 / 50	2500	170	355	470	365	425	12	22	146
LA 14 / 60	2500	170	355	470	365	425	12	22	146
LA 14 / 70	2500	170	355	470	365	425	12	22	146
LA 14 / 80	2500	170	355	470	365	425	12	22	146

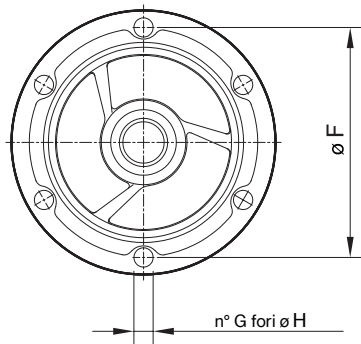

SHAFT WEIGHT

Ø mm SHAFT	WEIGHT Kg/1 m
20	2,5
24	3,5
30	5,5
35	7,5
40	9,8
45	12,4
50	15,3
60	22,1
70	30
80	39,2

Electric motor drive unit overall dimensions

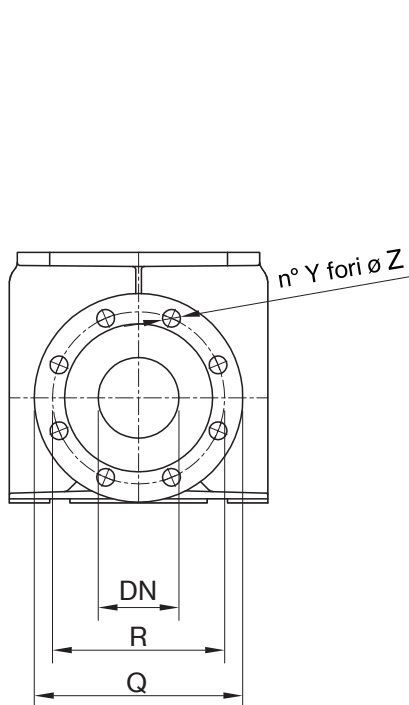
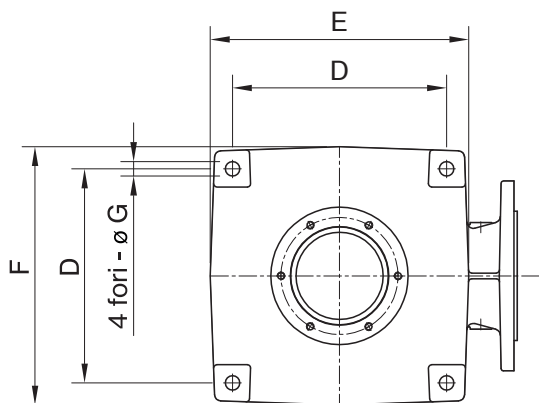

BASE

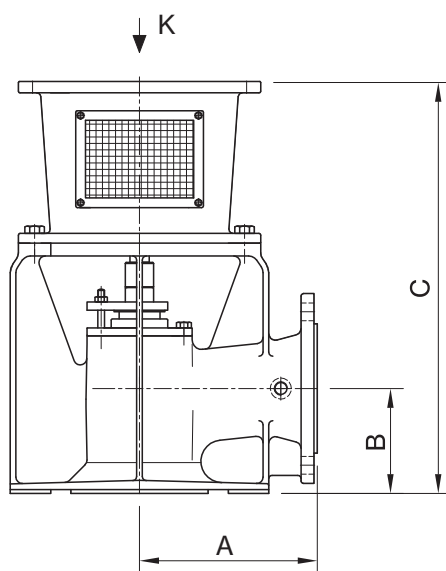

ELECTRIC MOTOR DRIVE

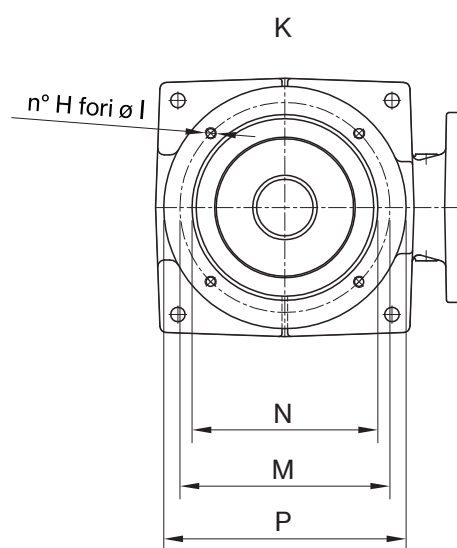

Electric motor drive unit overall dimensions and total weight

ELECTRIC MOTOR DRIVE	FLANGE DISCHARGE DN	BASE TYPE	A	B	C	D	E	F	G	H	I	M	N	P	STAINLESS STEEL TOTAL WEIGHT Kg	CAST IRON TOTAL WEIGHT
			mm									n°	mm			
E 0 / 3	100	B 4 / 3	220	130	510	265	320	320	18	4	M10	165	130	250	73,5	68
E 1 / 3	100	B 4 / 3	220	130	510	265	320	320	18	4	M12	215	180	250	73,5	68
E 1 / 4	100	B 4 / 4	220	130	510	265	320	320	18						73,5	68
E 1 / 5	150	B 6 / 5	280	180	620	345	425	415	21	4	M12	265	230	300	117,5	107
E 1 / 6	150	B 6 / 6	280	180	620	345	425	415	21						117,5	107
E 2 / 3	100	B 4 / 3	220	130	510	265	320	320	18	4	M12	265	230	300	87	81,5
E 2 / 4	100	B 4 / 4	220	130	510	265	320	320	18						87	81,5
E 2 / 5	150	B 6 / 5	280	180	620	345	425	415	21	4	M12	265	230	300	131	120,5
E 2 / 6	150	B 6 / 6	280	180	620	345	425	415	21						131	120,5
E 2 / 8	200	B 8 / 8	300	200	675	400	480	470	23	4	M16	300	250	350	176	160,5
E 3 / 3	100	B 4 / 3	220	130	562	265	320	320	18						103	97,5
E 3 / 4	100	B 4 / 4	220	130	562	265	320	320	18	4	M16	300	250	350	103	97,5
E 3 / 5	150	B 6 / 5	280	180	672	345	425	415	21						147	136,5
E 3 / 6	150	B 6 / 6	280	180	672	345	425	415	21	4	M16	300	250	350	147	136,5
E 3 / 8	200	B 8 / 8	300	200	727	400	480	470	23						192	176,5
E 3 / 10	250	B 10 / 10	400	250	802	550	620	620	30	4	M16	300	250	350	316	286,5
E 4 / 3	100	B 4 / 3	220	130	562	265	320	320	18						103	97,5
E 4 / 3	100	B 4 / 3	220	130	562	265	320	320	18	4	M16	300	250	350	103	97,5
E 4 / 4	100	B 4 / 4	220	130	562	265	320	320	18						103	97,5
E 4 / 5	150	B 6 / 5	280	180	672	345	425	415	21	4	M16	300	250	350	147	136,5
E 4 / 6	150	B 6 / 6	280	180	672	345	425	415	21						147	136,5
E 4 / 8	200	B 8 / 8	300	200	727	400	480	470	23	4	M16	300	250	350	192	176,5
E 4 / 10	250	B 10 / 10	400	250	802	550	620	620	30						316	286,5
E 5 / 3	100	B 4 / 3	220	130	610	265	320	320	18	4	M16	350	300	400	125	119,5
E 5 / 4	100	B 4 / 4	220	130	610	265	320	320	18						125	119,5
E 5 / 5	150	B 6 / 5	280	180	720	345	425	415	21	4	M16	350	300	400	169	158,5
E 5 / 6	150	B 6 / 6	280	180	720	345	425	415	21						169	158,5
E 5 / 8	200	B 8 / 8	300	200	775	400	480	470	23	4	M16	350	300	400	214	198,5
E 5 / 10	250	B 10 / 10	400	250	850	550	620	620	30						338	308,5
E 6 / 4	100	B 4 / 4	220	130	610	265	320	320	18	8	M16	400	350	450	125	119,5
E 6 / 5	150	B 6 / 5	280	180	720	345	425	415	21						169	158,5
E 6 / 6	150	B 6 / 6	280	180	720	345	425	415	21	8	M16	400	350	450	169	158,5
E 6 / 8	200	B 8 / 8	300	200	775	400	480	470	23						214	198,5
E 6 / 10	250	B 10 / 10	400	250	850	550	620	620	30	8	M16	400	350	450	338	308,5
E 6 / 12	300	B 12 / 12	400	290	910	510	600	600	28						384	349,5
E 7 / 4	100	B 4 / 4	220	130	642	265	320	320	18	8	M16	500	450	550	174	168,5
E 7 / 5	150	B 6 / 5	280	180	752	345	425	415	21						218	207,5
E 7 / 6	150	B 6 / 6	280	180	752	345	425	415	21	8	M16	500	450	550	218	207,5
E 7 / 8	200	B 8 / 8	300	200	807	400	480	470	23						263	247,5
E 7 / 10	250	B 10 / 10	400	250	882	550	620	620	30	8	M16	500	450	550	387	357,5
E 7 / 12	300	B 12 / 12	400	290	942	510	600	600	28						433	398,5
E 8 / 6	150	B 6 / 6	280	180	752	345	425	415	21	8	M20	600	550	660	238	227,5
E 8 / 8	200	B 8 / 8	300	200	807	400	480	470	23						283	267,5
E 8 / 10	250	B 10 / 10	400	250	882	550	620	620	30	8	M20	600	550	660	407	377,5
E 8 / 12	300	B 12 / 12	400	290	942	510	600	600	28						453	418,5
E 8 / 14	400	B 16 / 14	510	370	1127	650	800	800	37	8	M20	740	680	800	715	651
E 9 / 8	200	B 8 / 8	300	200	1005	400	480	470	23						474	458,5
E 9 / 12	300	B 12 / 12	400	290	1140	510	600	600	28	8	M20	740	680	800	644	609,5
E 9 / 14	400	B 16 / 14	510	370	1325	650	800	800	37						906	842
E 10 / 14	400	B 16 / 14	510	370	1325	650	800	800	37	8	M24	940	880	1000	1050	986

FLANGE DISCHARGE DN	PN	Q	R	Y	Z
		mm			
100	25	235	190	8	22
150	25	300	250	8	26
200	25	360	310	12	26
300	25	485	430	16	30
400	25	620	550	16	36



Electric motor overall dimensions

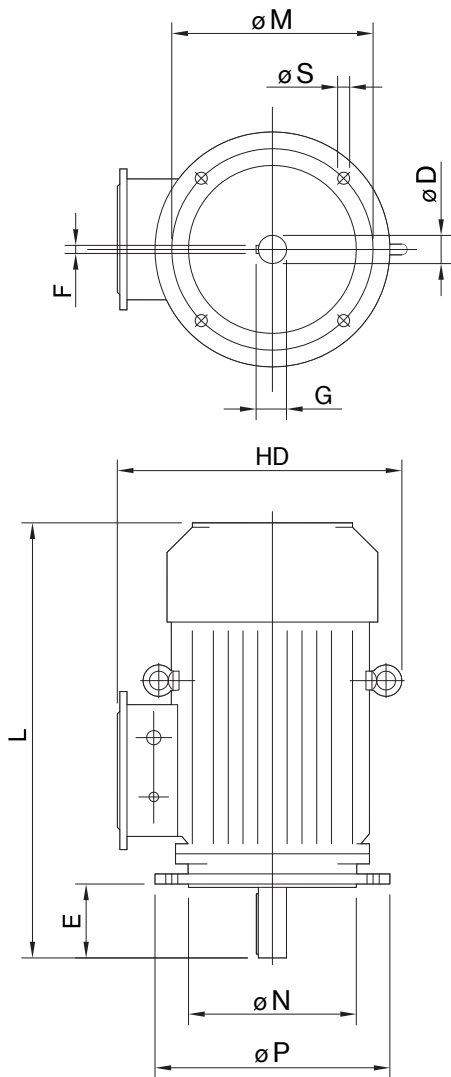

FRAME SIZE	POLE	DIMENSIONS (mm)									
		D	E	F	G	M	N	P	S	HD	L
112M	2...6	28	60	8	24	215	180	250	4-Ø15	305	450
132S	2...6	38	80	10	33	265	230	300	4-Ø15	365	510
132M	4...6	38	80	10	33	265	230	300	4-Ø15	365	550
160M	2...6	42	110	12	37	300	250	350	4-Ø19	445	660
160L	2...6	42	110	12	37	300	250	350	4-Ø19	445	705
180M	2...4	48	110	14	42,5	300	250	350	4-Ø19	480	750
180L	4...6	48	110	14	42,5	300	250	350	4-Ø19	480	790
200L	2...6	55	110	16	49	350	300	400	4-Ø19	530	840
225S	4...6	60	140	18	53	400	350	450	8-Ø19	575	905
225M	2	55	110	16	49	400	350	450	8-Ø19	575	910
	4...6	60	140	18	53	400	350	450	8-Ø19	575	935
250M	2	60	140	18	53	500	450	550	8-Ø19	635	1005
	4...6	65	140	18	53	500	450	550	8-Ø19	635	1005
280M	2	65	140	18	58	500	450	550	8-Ø19	725	1155
	4...6	75	140	20	67,5	500	450	550	8-Ø19	725	1185
315S	2	65	140	18	58	600	550	660	8-Ø24	865	1340
	4...6	80	170	22	71	600	550	660	8-Ø24	865	1370
315M/L	2	65	140	18	58	600	550	660	8-Ø24	865	1450
	4...6	80	170	22	71	600	550	660	8-Ø24	865	1480
315M/L	2	65	140	18	58	600	550	660	8-Ø24	865	1450
	4...6	80	170	22	71	600	550	660	8-Ø24	865	1480
355M/L	2	75	140	20	67,5	740	680	800	8-Ø24	970	1665
	4...6	95	170	25	86	740	680	800	8-Ø24	970	1740
400M/L	2	80	170	22	71	940	880	1000	8-Ø28	1150	2150
	4...6	110	210	28	100	940	880	1000	8-Ø28	1150	2220

Applications and special versions

WITH MOTOR HOLLOW SHAFT

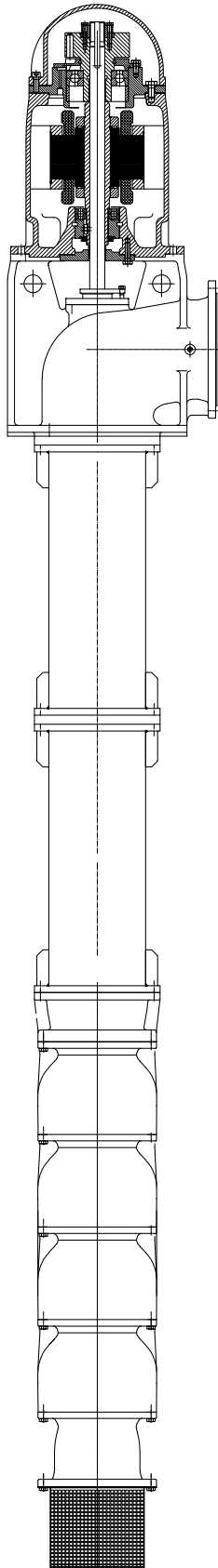

WITH ANGLE GEAR

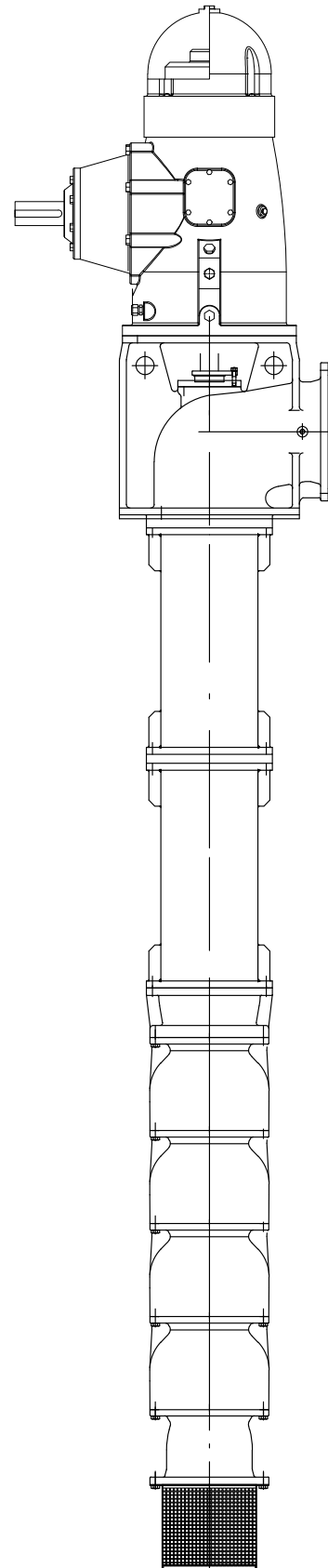

BARREL VERSION

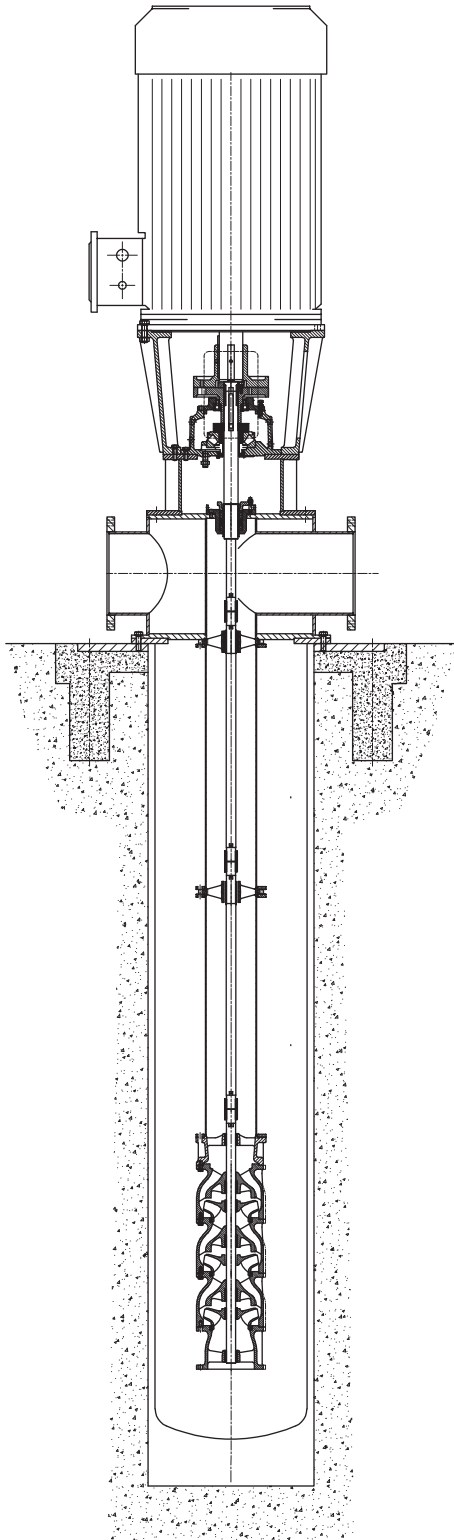

SPECIAL MATERIALS AVAILABLE

- Bronze
- AISI 316
- Duplex
- Super Duplex
- Ceramic hydraulic parts for abrasive liquid



TECHNICAL APPENDIX

Moment of inertia “J”

PUMP TYPE	STANDARD IMPELLER		BRONZE IMPELLER	
	1 STAGE PUMP	FOR EACH ADDITIONAL STAGE	1 STAGE PUMP	FOR EACH ADDITIONAL STAGE
VPL 6A	0,0008034	0,0007628	0,0009654	0,0009248
VPL 6B	0,0009436	0,0009029	0,001137	0,001096
VPL 6C	0,0009619	0,0009212	0,001159	0,001118
VPL 6D	0,001221	0,001190	0,001460	0,001430
VPL 6E	0,001385	0,001354	0,001659	0,001628
VPL 8B	0,005197	0,005047	0,006322	0,006172
VPL 8C	0,005497	0,005347	0,006622	0,006472
VPL 8D	0,006020	0,005870	0,007255	0,007105
VPL 8E	0,006761	0,006611	0,008127	0,007977
VPL 8F	0,007229	0,007079	0,008660	0,008510
VPL 10A	0,020750	0,020320	0,025130	0,024690
VPL 10B	0,019800	0,019360	0,023790	0,023350
VPL 10C	0,020020	0,019580	0,023930	0,023490
VPL 10D	0,020250	0,019800	0,024070	0,023630
VP 12A	0,039220	0,034150	0,047070	0,040980
VP 12B	0,040450	0,035380	0,048540	0,042450
VP 14A	0,131700	0,126000	0,158000	0,151200
VP 14B	0,132500	0,123800	0,158900	0,152200

In order to keep its products constantly ahead of technical evolutions, the manufacturer has reserved right, without any prior notification, to modify dimensions and characteristics of the products described in this catalogue.



Pumps installation depth

PUMP BODY	AXIS LINE	TOTAL MANOMETRIC HEAD IN METERS																													
		20	30	40	50	60	70	80	90	100	110	120	130	140	150	160	170	180	190	200											
TYPE	AXIS mm	INSTALLATION DEPTH IN METERS																													
VPL 8B	20	90							80																						
	24	100									90			80		70															
	30	120											110		100																
VPL 8G	20	90							80																						
	24	80							70																						
	30	120											110		100																
VPL 8D	20	80							70																						
	24	100									90			80																	
	30	120							110				100		90																
VPL 8E	20	70					60																								
	24	100							90																						
	30	90							100			90																			
VPL 8F	20	60																													
	24	90																													
	30	100											90		80		70														
VPL 10A	24	50																													
	30	80																													
	35	90							80			70																			
VPL 10C	24	50																													
	30	90							80																						
	35	100							90		80		70																		
VPL 10D	24	50																													
	30	90							80		70																				
	35	100							90		80		70																		



PUMPS INSTALLATION DEPTH

PUMP BODY	AXIS LINE	TOTAL MANOMETRIC HEAD IN METERS																				
		20	30	40	50	60	70	80	90	100	110	120	130	140	150	160	170	180	190	200		
TYPE	AXIS mm	INSTALLATION DEPTH IN METERS																				
VP 12A	30	70																				
	35	80							70	60												
	40	80									70			60								
VP 12B	30	70																				
	35	80							70	60												
	40	80									70			60								
VP 14A	35	70					60															
	40	70							60													
	45	80								70		60										
VP 14B	35	70					60															
	40	70							60													
	45	80								70		60										
VP 14C	35	70					60															
	40	70							60													
	45	80								70		60										
VP 16A	40	70					60															
	45	80							70	60												
	50	90								80		70	60									
	60	100									90		80	70								
VP 16B	40	70					60															
	45	80							70		60											
	50	90								80		70										
	60	100									90		80									
VP 16C	40	70					60															
	45	80							70		60											
	50	90								80			70									
	60	100									90		80									
VP 16D	40	70					60															
	45	80							70		60											
	50	90								80			70									
	60	100									90		80									



Foot valve pressure losses

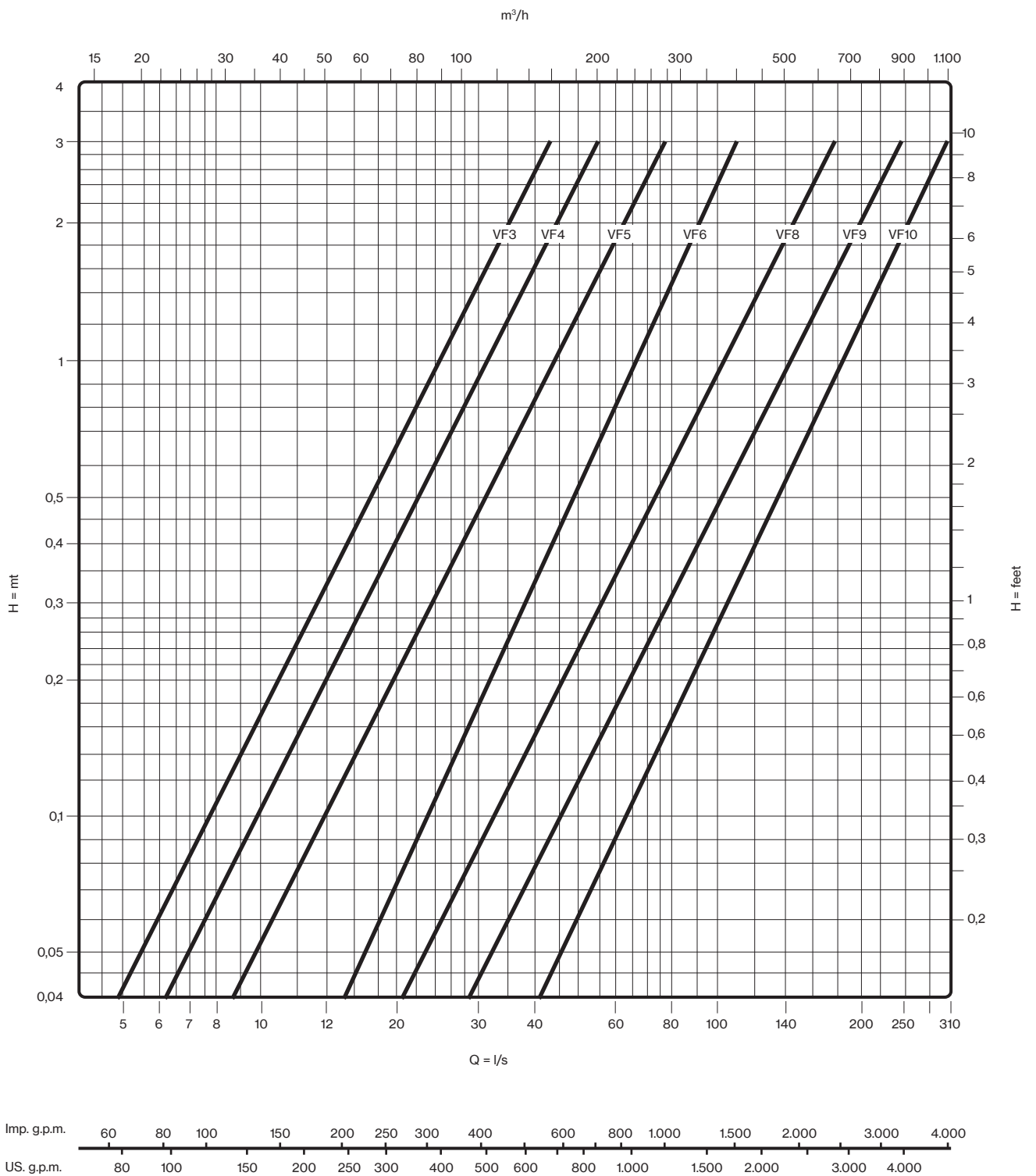

Head losses in metres for every 100 metres of straight piping

V	Q h	Diameter of the pipes in mm												
		20	25	30	40	50	65	80	100	125	150	175	200	250
0,5	Q	9,4	14,7	21,2	37,7	59	115	151	235	369	530	723	940	1480
	h	2,4	1,9	1,5	1	0,8	0,56	0,46	0,36	0,28	0,23	0,19	0,16	0,13
0,6	Q	11,3	17,7	25,4	45,3	70,7	138	181	282	442	636	887	1130	1770
	h	3,3	2,6	2,1	1,5	1,12	0,78	0,65	0,5	0,39	0,32	0,27	0,23	0,18
0,7	Q	13,2	20,6	29,7	52,9	82,5	161	211	329	516	742	1010	1315	2070
	h	4,4	3,4	2,7	1,9	1,5	1	0,86	0,67	0,52	0,43	0,36	0,31	0,24
0,8	Q	15,05	23,6	33,9	60,4	94,5	184	241	377	590	848	115	1505	2360
	h	5,6	4,3	3,4	2,5	1,9	1,3	1,1	0,86	0,67	0,55	0,46	0,4	0,31
0,9	Q	16,95	26,5	38,2	68	106	207	272	423	664	955	1300	1695	2660
	h	6,9	5,3	4,3	3	2,4	1,7	1,4	1,1	0,84	0,69	0,58	0,5	0,39
1	Q	18,8	29,5	42,4	75,5	117,7	230	302	471	737	1060	1445	1880	2950
	h	8,3	6,4	5,1	3,7	2,9	2,1	1,7	1,3	1	0,84	0,71	0,61	0,48
1,1	Q	20,7	32,4	46,6	83	129,5	252	332	518	811	1165	1585	2070	3250
	h	9,9	7,6	6,2	4,4	3,4	2,4	2	1,6	1,2	1	0,85	0,74	0,58
1,2	Q	22,6	35,4	50,9	90,6	141	276	362	565	885	1272	1730	2260	3550
	h	11,7	9	7,2	5,2	4	2,9	2,4	1,9	1,5	1,2	1	0,87	0,69
1,3	Q	24,5	38,3	55	98	153	299	392	612	960	1378	1875	2450	3840
	h	13,5	10,4	8,4	6	4,7	3,3	2,8	2,2	1,71	1,4	1,15	1	0,8
1,4	Q	26,35	41,3	59,3	105,5	165	302	422	660	1032	1473	2020	2635	4140
	h	15,4	11,9	9,6	6,9	5,4	3,8	3,2	2,5	2	1,6	1,3	1,17	0,92
1,5	Q	28,25	44,2	63,6	113	176,5	345	452	707	1106	1590	2165	2825	4430
	h	17,4	13,5	10,9	7,8	6,1	4,4	3,6	2,8	2,25	1,82	1,5	1,34	1,05
1,6	Q	30,1	47,1	67,8	121	188,5	368	483	753	1180	1695	2310	3010	4730
	h	19,6	15,3	12,4	8,9	6,9	4,9	4,1	3,2	2,55	2,05	1,7	1,53	1,18
1,7	Q	32	50,1	72	128	200	392	513	800	1253	1802	2455	3200	5020
	h	21,9	17,2	13,9	10	7,8	5,4	4,6	3,6	2,85	2,3	1,95	1,7	1,33
1,8	Q	33,9	53	76,3	136	212	415	543	848	1327	1905	2600	3390	5320
	h	24,2	19,1	15,4	11,1	8,7	6	5,1	4	3,15	2,6	2,2	1,9	1,48
1,9	Q	35,8	56	80,5	143,5	224	438	573	895	1400	2015	2740	3580	5610
	h	26,8	21	17	12,3	9,6	6,8	5,6	4,4	3,45	2,85	2,45	2,1	1,64
2	Q	37,7	59	84,8	151	235,5	461	603	943	1475	2120	2885	3765	5910
	h	29,6	23	18,6	13,4	10,5	7,5	6,2	4,9	3,8	3,17	2,7	2,33	1,8
2,1	Q	39,5	62	89	158,5	247,5	484	633	990	1548	2225	3030	3955	6200
	h	33,2	25,1	20,4	14,8	11,5	8,2	6,8	5,4	4,2	3,5	2,95	2,55	2
2,2	Q	41,5	64,9	93,2	176	259	507	663	1036	1620	2330	3175	4145	6500
	h	35	27,3	22,3	16,2	12,5	9,1	7,4	5,9	4,6	3,85	3,25	2,8	2,2
2,3	Q	43,3	67,9	97,5	173,5	271	530	694	1082	1695	2440	3320	4330	6800
	h	38	29,7	24,2	17,7	13,6	9,8	8,1	6,4	5	4,15	3,5	3,05	2,4
2,4	Q	45,2	70,8	101,5	181	282,5	553	724	1130	1170	2545	3460	4520	7090
	h	42,1	32,1	26,2	19,1	14,7	10,6	8,8	6,9	5,45	4,55	3,8	3,3	2,62
2,5	Q	47,1	73,7	105,8	189	294,5	576	755	1178	1843	2650	3610	4710	7390
	h	45	34,7	28,3	20,5	16	11,4	9,6	7,5	5,9	4,9	4,1	3,58	2,84
2,6	Q	49	76,6	110	196	306	599	785	1225	1915	2755	3755	4900	7680
	h	48,3	37,3	30,4	22,2	17,2	12,3	10,4	8,1	6,35	5,25	4,4	3,85	3,07
2,7	Q	50,9	79,6	114,3	204	318	622	815	1271	1990	2860	3900	5090	7980
	h	51,7	40	32,5	23,8	18,5	13,2	11,2	8,7	6,85	5,65	4,75	4,15	3,3
2,8	Q	52,7	82,6	118,5	211,5	330	645	845	1320	2060	2970	4040	5280	8270
	h	55,2	42,5	34,8	25,5	19,9	14	12	9,3	7,35	6,05	5,10	4,45	3,56
2,9	Q	54,6	85,5	123	219	342	668	875	1365	2140	3075	4190	5460	8560
	h	58,7	45,1	37,1	27,1	21,3	15,2	12,8	10	7,85	6,45	5,5	4,75	3,82
3	Q	56,5	88,5	127	226,5	354	691	905	1414	2210	3180	4330	5650	8850
	h	62,9	47,9	39,6	28,8	22,6	16,3	13,6	10,7	8,4	6,9	5,9	5,1	4,1

Q= Capacity in litre per min

V= Water velocity in m/sec

h= Head loss in m of water for every 100m of straight piping

Note: above data are relevant to completely smooth and cast-iron piping.
For a general estimation, multiply the head losses data by:

- 0,8 flat rolled new steel piping
- 1,25 slightly rusty steel piping
- 0,7 piping in aluminium
- 0,65 piping in PVC
- 1,25 piping in concrete fibre



Axis line head losses

CAPACITY		AXIS LINE TYPE																			
		LA3/20	LA3/24	LA4/20	LA4/24	LA4/30	LA5/20	LA5/24	LA5/30	LA6/24	LA6/30	LA6/35	LA8/40	LA10/45	LA10/50	LA12/45	LA12/50	LA12/60	LA14/55	LA14/65	LA14/70
m ³ /h	l/min	HEAD LOSSES IN METERS EVERY 100 METRES OF AXIS LINE																			
18	300	2	2,5																		
24	400	3,6	4,6																		
30	500	5,5	7																		
36	600	8	9,8																		
42	700	10,7	12,8	3	3,6	5,4															
48	800	14	16,6	4	4,6	6,6															
54	900	17	20,7	4,8	5,8	7,8															
60	1000	21	25	5,8	7	9,3															
72	1200			8	9,8	12,5	3,4	3,8	4,6												
84	1400			10,8	13	16,4	4,6	5	6,1												
96	1600			14	17	21	5,9	6,5	8												
108	1800			18,2	22	27,7	7,3	8,2	10	1,8	2,3	2,5									
120	2000						8,8	10	12,2	2,2	2,8	3,1									
135	2250						11	12,6	15,4	2,8	3,4	3,8									
150	2500						13,6	15,6	19	3,4	4,2	4,6									
165	2750						16,5	19	23	4,1	5	5,6									
180	3000						20	23	28	5	5,8	6,6	2,1								
195	3250						23,8	27,7	34	5,7	6,8	7,7	2,4								
210	3500									6,6	7,8	8,9	2,8								
225	3750									7,5	8,8	10,2	3,3								
240	4000									8,5	10	11,5	3,7								
255	4250									9,5	11,2	12,8	4,2								
270	4500									10,5	12,5	14,2	4,6								
285	4750									11,6	13,8	15,8	5,2								
300	5000									12,8	15,2	17,5	5,7	2	2,2						
330	5500									15	18,4	20,8	6,8	2,4	2,5						
360	6000												8	2,8	3						
390	6500												9,4	3,4	3,6						
420	7000												10,6	3,8	4,1	1,2	1,3	1,4			
450	7500												12,3	4,4	4,6	1,3	1,4	1,5			
480	8000												13,5	4,9	5,2	1,5	1,6	1,7			
510	8500												15,2	5,5	5,9	1,7	1,8	1,9			
540	9000												17	6,2	6,5	1,9	2	2,1			
570	9500													6,9	7,2	2,1	2,2	2,3			
600	10000													7,5	7,9	2,3	2,4	2,5			
660	11000													9	9,5	2,7	2,8	2,9			
720	12000													10,5	11	3,2	3,4	3,6			
780	13000													12	12,7	3,8	4	4,2			
840	14000													14	14,8	4,4	4,6	4,8			
900	15000													15,8	16,7	4,9	5,2	5,5	1,5	2,5	3,2
960	16000															5,5	5,8	6,1	1,7	2,8	3,8
1020	17000															6,4	6,7	7	1,8	3,1	4
1080	18000															7	7,3	7,6	2,2	3,5	4,6
1140	19000															7,7	8,1	8,5	2,4	3,8	5
1200	20000															9	9,4	9,8	2,5	4,4	5,5
1320	22000															10,3	10,8	11,3	3	5	6,5
1380	26000																		3,5	6	7,5
1500	25000																		4	6,5	8,5
1620	27000																		4,2	7	9
1740	29000																		5,2	8,5	10,1
1800	30000																		5,5	9	10,3



Absorbed power every 10 meters of axis line

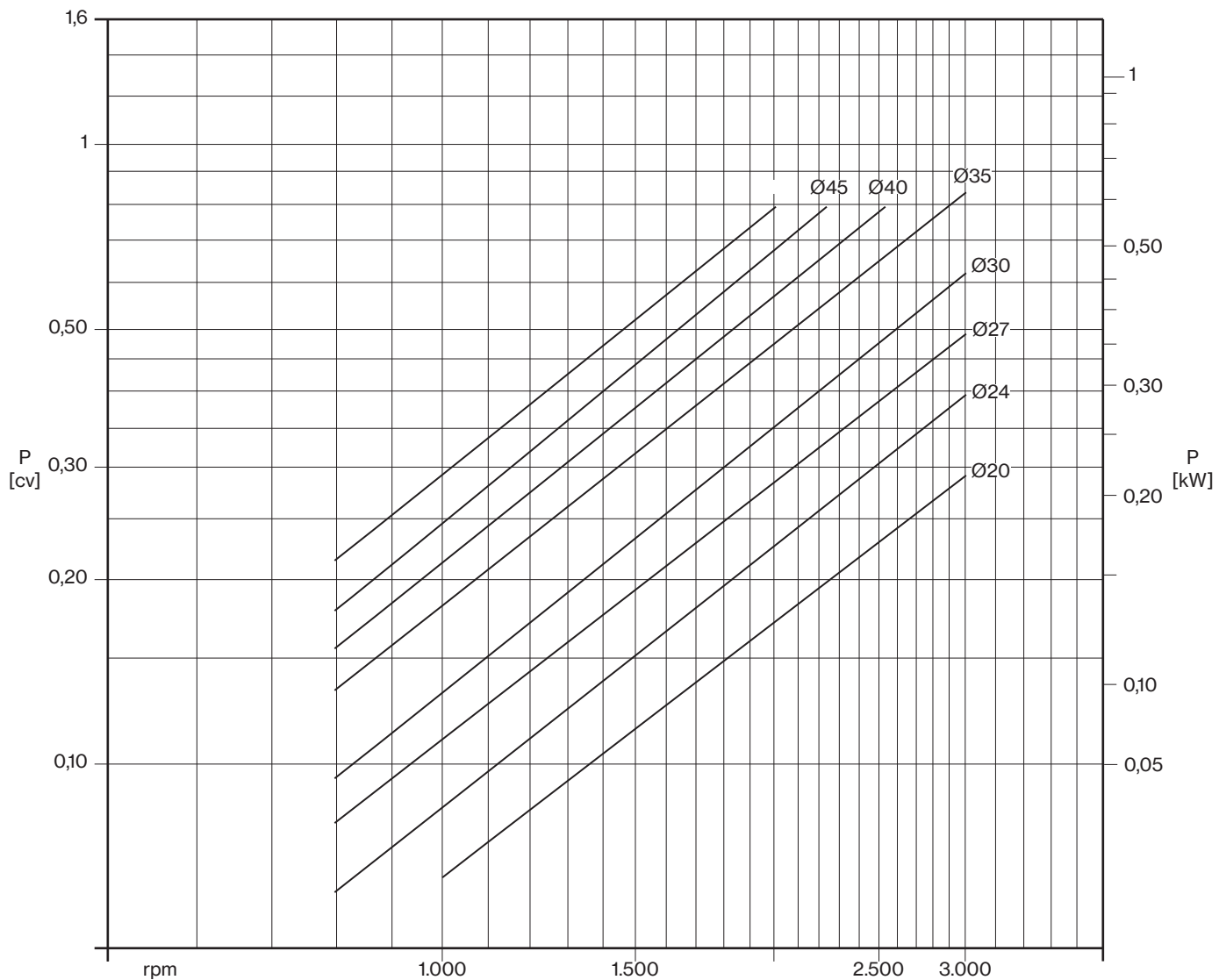

Power absorbed by the gland

SHOWN IN THE DIAGRAM HAVING A SPEED 1450 Rpm

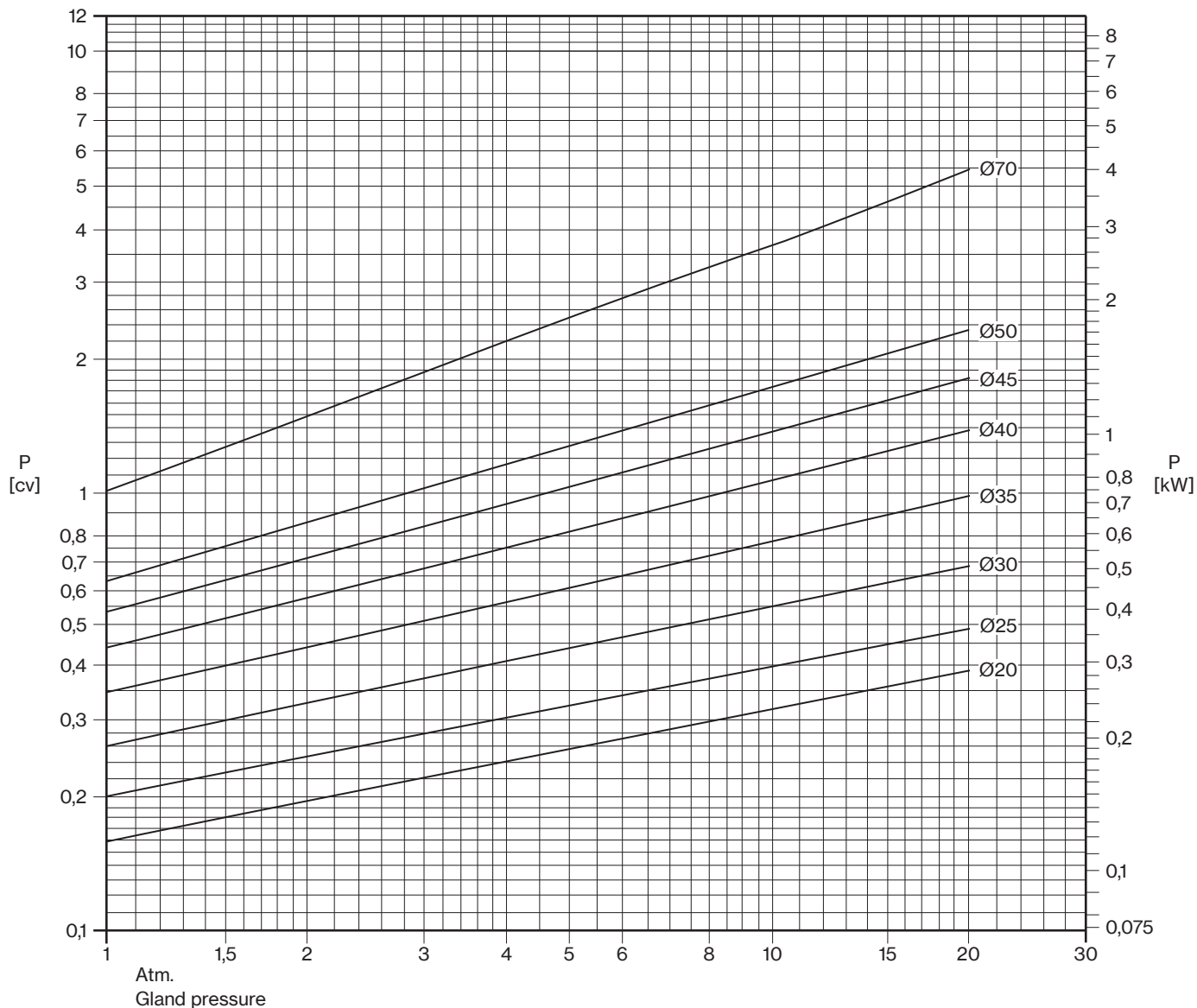

For different rpm (n) the loss (Px) can be calculated with: $P_x = \frac{P}{1450} \times n$

HEAD BASE	HEADS				
	VE1 OR1 OM1	VE2-VEO2 OR2-OM2 ME2N-ME20	VE3 OR3-OM3 OM35-ME3N	OR4 OM4 ME4	OR5 ME5
	Ø GLAND				
3"	20	25	30	-	-
4"				35	35
5"					
6"	-	50			
8"		40			
10"		-			
12"		70			



Axis line transmissible powers

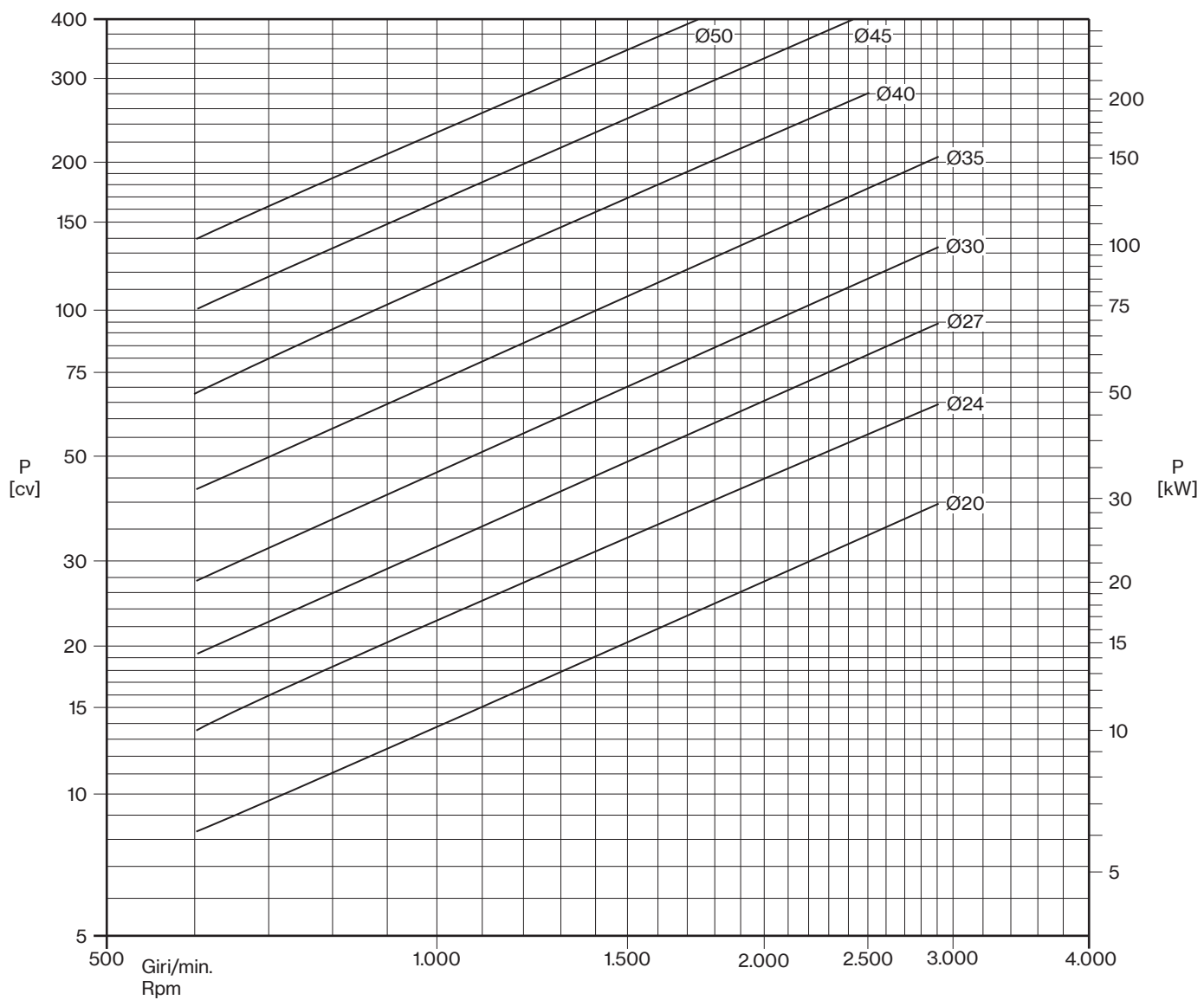

Measurement comparison in unit

Measurement comparison in unit				
	CV	HP	kW	kgm/s
CV	1	0,9863	0,7355	75
HP	1,0139	1	0,7457	76,05
kW	1,36	1,341	1	101,98

Pressure	
Unit	Comparison
1 kg/cm ² = 9,81 · N/cm ² = 0,981 bar = 98100 Pa	1 Pa = 1 · N/cm ² = 1 Pascal
1 kg/cm ² = 1 at = 10000 kg/m ² = techn. atmosphere = 10 m water col at 4° C = 735,56 Torr (mm Hg at 0°C)	
1 lb per square inch = 1 psi = 0,0703 kg/cm ²	1 kg/cm ² = 14,2 psi

Capacity measures compared at litre				
Unit	Comparison	Unit	Comparison	
Imperial fluid ounce	0,0284 litre	litre	35,2	Imp. fl. oz.
U.S. fluid ounce	0,0295 litre	litre	33,81	U.S. fl. oz.
Imperial pinte	0,568 litre	litre	1,76	Imp. pinte
U.S. gallon	3,785 litre	litre	0,2642	U.S. gal.
Imperial gallon	4,546 litre	litre	0,22	Imp. gal
U.S. bushel	35,24 litre	litre	0,0284	U.S. bu.
Imperial bushel	36,35 litre	litre	0,0275	Imp. bu.
U.S. barrel	119,22 litre	litre	0,0083	U.S. bbl.
Imperial barrel	163,65 litre	litre	0,00611	Imp. bbl.



Technical appendix

Notices on centrifugal pumps

Efficiency calculation (known):

Q - capacity l/s

H - total head in m

Pa - absorbed power in kW

g - density in Kg/dm³

$$\eta = g \cdot \frac{Q \cdot H}{102 \cdot Pa} \quad [\text{kW}]$$

Absorbed power calculation Pa (known):

Q - capacity l/s

H - total head in m

η - efficiency

g - density in Kg/dm³

$$Pa = g \cdot \frac{Q \cdot H}{102 \cdot \eta} \quad [\text{kW}]$$

Working curves

Between the working curves of a centrifugal pump at different speed, is in force the affinity law, provided that there aren't cavitation effects, and that could be like this:

curves Q-H and Q-Pa at n. rounds are changed in Q'-H' and Q'-Pa' at n' rounds.

According to:

$$Q' = \left(\frac{n'}{n}\right) \cdot Q \qquad H' = \left(\frac{n'}{n}\right)^2 \cdot H \qquad Pa' = \left(\frac{n'}{n}\right)^3 \cdot Pa$$